



TWISTED THROTTLE

Bolt-On Touring Accessories that fit YOUR motorcycle!



HARD LUGGAGE & RACK SYSTEMS

- SW-MOTECH
- Givi
- TraX
- Pelican
- Coocase

SOFT LUGGAGE

- Quick-Lock Tankbags
- Electrification Kits
- Rear Seat Bags
- Saddlebags
- Dry Bags

BOLT-ON EQUIPMENT

- Crashbars
- Skid Plates
- Frame Sliders
- Engine Protection
- Centerstands
- Adjustable Footpegs
- Air Horns
- Add-On Lighting

HANDLEBAR EQUIPMENT

- Risers & Barbacks
- Crossbars
- Handguards
- Mirror Wideners
- Smart Phone Holders
- Gadget Mounts
- Throttle Locks
- Radar Detectors

WIND PROTECTION

- Adjustable Touring Screens
- Sportbike Windscreens
- Handlebar-mounted Windscreens

PROTECTION & COMFORT

- Riding Apparel
- Gloves
- Heated Grips
- Heated Clothing

Visit us online to find more bike-specific products, photos, and reviews from other riders.

WWW.TWISTEDTHROTTLE.COM

The year in photos!

Here are just a few of our favorites.



R.I. Senator Sheldon Whitehouse visits Twisted Throttle!



Teach McNeil lapin' down some nice "trix" in the old Twisted parking lot. See page 237 for more about Teach.



Dan from GSM MotoRent taking the Twisted Tenebre to new heights. See page 234 for details about this Killer Tenebre.



River crossings are synonymous with Alaskan adventure. See page 238 for more about MotoQuest Tours.



PR Manager, Ken, shortly after riding one too many wet laps at the Loudon Racetrack. Don't ask.



Patrick Trahan "in deep" somewhere in Africa. Turn to page 236 for a report on Patrick's African adventure... and mishaps.



Erik's Italian grandparents.

2012 will be even better!

STOP BY AND SEE US!



Turn to page 240 for Events and Rally dates across the country.



The Twisted Donkey. He's always making an ass of himself at our staff parties.

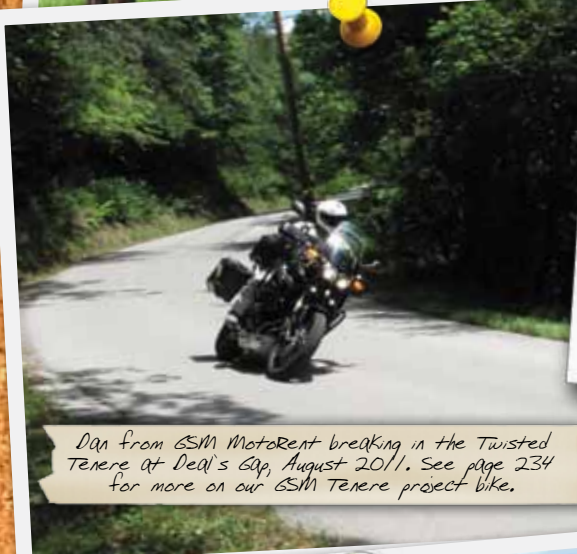

Dan from GSM MotoRent breaking in the Twisted Tereze at Deal's Gap, August 2011. See page 234 for more on our GSM Tereze project bike.



"Motoquest Phil's" happy KLR relaxing on the Denali Highway in Alaska last August. See page 238 if you want to join Motoquest on this ride next year!

Visit our new World Headquarters!



Twisted Throttle has moved to our new location at 570 Nooseneck Hill Rd, Exeter, RI 02822

This ain't no sideways move...no way! The new place is modern and marvelous with 27,000 square feet of space that includes a retail store, warehouse, installation bays, tire changing services, prototyping workshop, and videography studios. It even has a bar (cola on the rocks, please), a presentation stage, a 10' wide movie screen, and PINBALL machines!

Twisted Throttle is already a favorite destination for many of our customers, but the easily accessible location off I-95 in Exeter, RI will make spontaneous ride-ins and planned long-distance visits faster and more fun. Not only is the new location perfect for hanging out with fellow riding fanatics, it's also great for holding seminars, maintenance days, training events, moto movie nights, holiday parties and other epic happenings.

Come check out our new digs during our 10th Anniversary Open House Party on May 19, 2012!



Scan this code to view a map and get directions to our location.

Follow us on Facebook, Twitter & YouTube

Follow us on **Facebook** and **Twitter** where you will be able to provide product design feedback, see new product announcements, and get insider special offers! And, follow us on **YouTube** to see more about our products, and our project bike builds!

You can also sign up to receive our **Email Newsletter** so you can stay on top of all of the Twisted happenings.



What are these strange boxes?

They are called QR Codes. Use your smart phone's QR code reader app to scan QR codes to view videos and relevant web pages with detailed product information. **Don't have a fancy phone?** Visit TwistedThrottle.com to sign up for our Facebook, Twitter, or YouTube channels and email newsletter!



About Twisted Throttle...

OUR MISSION

If you're asking yourself "What Fits My Bike?", then you've come to the right place! Twisted Throttle specializes in bolt-on equipment that makes your metric motorcycle better protected, more comfortable, and more practical for battle commuting and long-distance travel. We've done the homework so you can easily find detailed bike-specific product fitting information, photos, installation tutorials, and reviews of the items you need most. We can outfit *YOUR* bike's make, model, and year, regardless of how obscure, so that you'll be ready for your next journey of a lifetime.

CUSTOMER SERVICE

We know motorcycles, and we know our product! All Twisted crew members have a motorcycle driver's license. Many are trained experts that have been installing and using the gear in this catalog for many years. If you have questions on any item or order, please call us at +1 (401) 284-4200. If we don't have the answer we will find it for you!

COME VISIT!

If you are traveling through New England, come visit our showroom in Exeter, Rhode Island! Give us a call and we'll help you with hotel or camping arrangements, directions, etc. You can download maps and directions at TwistedThrottle.com/contact.

DEALERS – WE WANT YOU!

Interested in selling products distributed by Twisted Throttle? Visit TwistedThrottle.com/becomeadealer to get started.

CATALOG

Visit Twistedthrottle.com/getacatalog to let us know if you would like to receive a catalog, or if you wish us to send a catalog to a friend.

MAILING LIST

We do not share our mailing list with any outside organizations, and will only send you our email newsletter upon your request. Twistedthrottle.com/newsletter

WHERE ARE ALL THE PRICES?

If we left out the price of an item, please visit us at www.TwistedThrottle.com, drop us an email (info@twistedthrottle.com) or call us at +1 (401) 284-4200 or toll free +1 (855) 255-5550 for pricing. Prices printed in this catalog are subject to change at any time.



Twisted Product Designer, Nate, testing the D2B and D3B DrySpec Dry bags.

Product Overview

BOLT-ON EQUIPMENT

Crashbars	4
Light & Footpeg Mounts for Crashbars	5
Centerstands	6
Skid plates	7
Rear Brake Guards and Sidestand Feet	8
Radiator & Oil Cooler Guards	9
Handlebar Risers	10
Handguards	12
Throttle Locks	16
Crash Protection & Rearsets	18
Mirror Wideners	30
Adjustable Footpegs	32

WIND PROTECTION

MRA Windscreens	36
Givi Windscreens	41

TIRES & TIRE ACCESSORIES

MEFO & Avon Tires	44
Tire Repair Kits, Inflators & Tools	48

ELECTRONICS

Video Cameras, GPS, Bluetooth Intercoms & Radar Detectors	50
Gadget Mounts & Device Cradles	53
Electrical Sockets	61
Tankbag Electrification & USB adapters	62
Auxiliary Light Kits & PIAA Bulbs	64
Battery Chargers	68
Flashlights	69
Power Distribution & Voltmeters	70
Horns	71
Heated Grips	72

RIDING GEAR

Heated Clothing	72
Macna Riding Jackets	74
Macna Riding Pants	78
Macna Gloves	79

LUGGAGE & RACK SYSTEMS

Rear Luggage Racks	80
QUICK-LOCK Side Luggage Carriers	84
Blaze Sport Saddlebag System	88
Aero Sidecases	90
TraX ALU BOXES & Accessories	92
Bottle Mounts & Storage Tubes for QUICK-LOCK Side Luggage Carriers	100
ROTOPAX Fuel & Water Cells	102
Pelican Storm Cases	104
Coccase Topcases	106

Givi Luggage Cases	112
LED Lighting for Hard Luggage	114
Retroreflective Visibility Kits	116
LED Light Bars	118
Visor Care, Passenger Grips & Stash Box	119

SOFT LUGGAGE

QUICK-LOCK TANKRINGS

QUICK-LOCK Tankrings	120
QUICK-LOCK Electric Tankrings	122
Tankbag GPS Mounts & Accessories	124

TANKBAGS

Sport	127
Micro	128
Daypack	129
Engage	130
Trial	131
City	132
GS	133
Enduro	134
Enduro LT	135

REAR SEAT BAGS

Slipstream	136
Jetpack	137
Rearbag	138
Cargobag	139
Racepack	140
Speedpack	141
Tentbag	142
Rackpack	143
Bags-Connection dry bags	144
DrySpec dry bags	146
Soft Luggage Carriers	148

LUGGAGE ACCESSORIES

Locks, Bungees & Rok Straps	149
Tankbag & Rearbag Application Chart	150

CAMPING GEAR

Nemo Tents & Sleeping Pads	154
----------------------------	-----

Erik (aka Mr. Twisted) on the way to Valdez during a MotoQuest Alaska tour.



What Fits My Bike?

BMW	
G450X	156
G650 Xcountry, Xchallenge, & Xmoto	156
F650GS single & F650GS/Dakar, -'07	156
G650GS (2011 & Later), Sertao (2012)	157
F650GS twin	158
F800GS	159
F800R	160
F800S & F800ST	161
S1000RR	162
R1150GS & R1150GS Adventure	164
R1100GS	165
R1150R & R1150R Rockster	165
R1200GS	166
R1200GS Adventure	168
R1200RT	169
R1200R	170
K1200GT & K1200RS	171
K1300GT & K1200GT	171
K1300R, K1200R & K1200R Sport	172
K1300S & K1200S	172
BUELL	
XB9/XB12 Models	173
CAN-AM	
Spyder Roadster	173
DUCATI	
Multistrada 1200	174
Multistrada 620, 1000, 1100	175
Streetfighter, 1198, 1098, & 848	175
Hypermotard	176
Monster	176
HONDA	
CBR125	177
CBR250	177
CRF230L & CRF230M	178
CBF600SA	178
CBR600F & CBR600F4i	179
CBR600RR	179
VT600, VT750 & VT1100 Shadow	180
Silverwing 600	180
XL600V, 650V & 700V Transalp	181
XR650L & XR650R	181
DN-01	182
NT700V Deauville	182
VFR800 Interceptor	183
919 / CB900 Hornet	183
CB1000R	184
CBF1000	184

CBR1000RR Fireblade	185
XL1000V Varadero	185
CBR1100XX Blackbird	186
VFR1200F	186
ST1300	186
KAWASAKI	
KLX250S	187
Super Sherpa 250	187
Ninja 250R & Ninja 500R	188
ZX6R & ZZR600	189
ER6n & Ninja 650R (2008 & Earlier)	189
ER-6f & Ninja 650R (2009 & Later)	190
ER6n (2009 & Later)	191
KLR650A (1987 - 2007)	192
KLR650E (2008 & Later)	193
Versys (2007 - 2009)	194
Versys (2010 - 2012)	195
GTR1000 / ZG1000 Concours	196
Ninja 1000	196
Z1000 (2003 - 2012)	197
ZX10R	197
GTR1400 Concours	198
ZX-14	198
KTM	
EXC	199
690 Enduro & 690 SMC	199
LC4	200
LC8 Adventure 950/990	201
LC8 SM, SMR & Super Enduro 950/990	202
LC8 SMT 990	203
SUZUKI	
AN400 Burgman	204
DRZ400S & DRZ400SM	204
GS500E & GS500F	205
GSX-R600	205
AN650 Burgman & Burgman Executive	206
GSF650 & GSF650S Bandit	206
DR650SE	207
Gladius SFV650	207
DL650 V-Strom (2004 - 2011)	208
DL650 V-Strom (2012)	209
GSX650F	210
SV650 & SV650SF	210
DL1000 V-Strom	211
GSX-R750 & GSX-R1000	212
SV1000 & SV1000S	212
GSF1250 Bandit	213

GSX1250FA	213
Hayabusa GSX1300R & GSX1340R	214
TRIUMPH	
Daytona 675	215
Street Triple 675 & Street Triple 675 R	215
Bonneville, T100, & America	216
Thruxton & Scrambler	216
Tiger 800 & 800XC	217
Sprint RS & ST 955	218
Tiger 955i & 900	215
Speed Triple 955 & Speed Triple 1050	218
Sprint ST 1050 & Sprint GT	219
Tiger 1050	219
Tiger Explorer 1200	220
VICTORY	
All models	220
YAMAHA	
WR250X & WR250R	221
Majesty 400	221
T-Max 500	222
FZ6	222
FZ6R	223
YZF-R6, & YZF-R6S	223
FZ8	224
FZ1 (2001 - 2005)	224
FZ1 (2006 & Later)	225
YZF-R1	225
XT1200Z Super Tenere	226
FJR1300	227
COOL STUFF	
T-shirts, Hats & Swag	228
Dealer Displays	230
Project Bikes	231
Sponsored Riders	236
MOTOQUEST TOURS	
2012 Featured Tours	238
EVENTS & ORDERING	
Event Calendar	240
How to Order	241

This section of the catalog provides detailed info on a limited portion of our bike-specific products and is **NOT** a comprehensive list of all available products. **Visit our website for more information on additional bikes.**

Graphic Designer and videographer, Matt B, soon after "testing" SW-MOTECH's Versys crashbars in Austria.

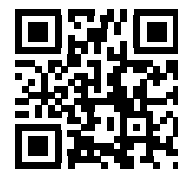

Scan the QR to see a video of how the SW-MOTECH Versys fared after Matt's Alps get-off!



Crashbars

Yamaha XT1200Z Super Tenere



SBL.06.162.10000.B

SW-MOTECH Crashbars offer rugged protection for your motorcycle. Each crashbar is carefully designed for an integrated look, precision fit, and heavy-duty performance.

During production, crashbars are sandblasted, and powdercoated to provide corrosion-resistant and glossy finish.

Starting At
\$159⁹⁹

See the "What Fits My Bike?" section of the catalog (pages 156-227) for bike-specific crashbar information.

KTM LC8 Adventure 990



SBL.04.488.100

Kawasaki KLR650E



SBL.08.297.10001

Ducati Multistrada 1200



SBL.22.142.10000.B

Suzuki DL650 V-Strom, '04-'11



SBL.05.757.10000.B

BMW F650GS Twin / F800GS



SBL.07.556.100

Upper Tank Crashbars for BMW R1200GS



SBL.07.565.100

Now available for the **BMW R1200GS**, our beefy upper tank crashbars provide additional protection for your off-road adventure. Upper tank crashbars can only be installed in addition to our lower crashbars.

The upper crashbar includes integrated mounting points for auxiliary driving lights. Check out our Denali auxiliary driving light kits on page 68.

See page 166 for more items for the **BMW R1200GS**.

SBL.07.552.100 - 04-07

\$254⁹⁹

SBL.07.565.100 - 08-12

\$244⁹⁹

Crashbar Accessories expand the versatility of your crashbars. With these accessories you are able to quickly and easily mount auxiliary lighting, footpegs, and cameras onto all common handlebar and crashbar sizes.

Auxiliary Light Mounting Clamps

Triumph Tiger 1050 Crashbars with Denali LED Lights

Easily mount your favorite auxiliary lighting to your crashbar using this mounting kit. The kit includes everything you need to securely mount one pair of lights to your handlebars or crashbars with diameters from 21.3mm (.85") to 26.9mm (1.07"). Your lights will illuminate your way into the night and give you that extra bit of conspicuity to alert drivers to your presence. When it comes to choosing premium lighting kits, we recommend the Denali D1 or Denali D2 lighting systems. See pages 64-67 for details.



Auxiliary light mounting clamps	Notes	Price	Part Number
Fits 21.3 mm, 7/8" (22mm), 1" (25.4mm), 26.9mm, and 1-1/8" (28mm) diameter bars. Pair.	Fits SW-MOTECH, Givi, and most other aftermarket and original crashbars. Available in black or silver.	\$49.95	TM.51125
Denali light kits	See pages 64-67.		Various

Footpegs

If you'd like to increase comfort for those long trips, you may want to consider mounting footpegs onto your crashbars. *MFW's* sweet bar-mounted footpeg system is easy to install and looks cool. There are three footpeg styles to choose from. Footpegs and folding footpeg mounts are sold separately (you need one pair of each).

Want even more ergo adjustments? Check out *MFW's* adjustable footpegs on page 32.



Footpegs	Notes	Price	Part Number
Super Grip anti-vibration footpegs, pair	Mounts to any 1/4" (6mm) diameter hole. Silver or black with black rubber footbed.	\$60.00	MFW.050.00.04.00
Master Grip footpegs, pair	Mounts to any 1/4" (6mm) diameter hole. Silver or black.	\$40.00	MFW.050.00.03.00
Racing footpegs, pair	Mounts to any 1/4" (6mm) diameter hole. Silver or black	\$40.00	MFW.050.00.01.00
Folding footpeg mounts	Notes		Part Number
Bar-mounted folding footpeg mounts, pair	Fits 0.85" (21.3mm) - 1.125" (28mm) diameter bars, including all SW-MOTECH and Givi crashbars. Footpegs sold separately. Silver or black.	\$80.00	MFW.SBL
Flush-mounted folding footpeg mounts, pair	For any flat surface with a 10mm mounting hole, including the built-in mount hole on SW-MOTECH crash-bars for Kawasaki KLR650E or BMW F800GS/F650GS Twin. Footpegs sold separately. Black.	\$60.00	MFW.050.00.10.M10

Camera Mounts



Universal Camera Mount Kit

Includes bar mount, 3" extension arm, and camera holder with 1/4-20 threaded stud. Fits most typical video cameras with a threaded hole. Fits bars up to 1.25" diameter.

RAM-B-149Z-C1U
\$33.18



GoPro Adapter

Connects a GoPro camera to the Universal Camera Mount Kit.

GPR.GTRA30
\$7.99



Go to page 56 for GoPro cameras.

Contour Mount Kit

Includes bar mount, 3" extension arm, and camera holder with 1/4-20 threaded stud for Contour GPS and Contour HD cameras. Fits bars up to 1.25" diameter.

RAM-B-149Z-237U
\$31.18



Go to page 51 for more camera mount options.



Centerstands

Centerstands make tire changes and chain maintenance much easier. Our centerstands are tested to make sure they do not limit the bike's maximum lean angle or ground clearance.

Centerstands are constructed using mild steel tubing. Prior to powder-coating, all centerstands are sandblasted and chemically treated to provide the best protection against corrosion.

See the "What Fits My Bike?" section of the catalog (pages 156-227) for bike-specific centerstand information.

Scan this code for an explanation of how and when to use a centerstand.

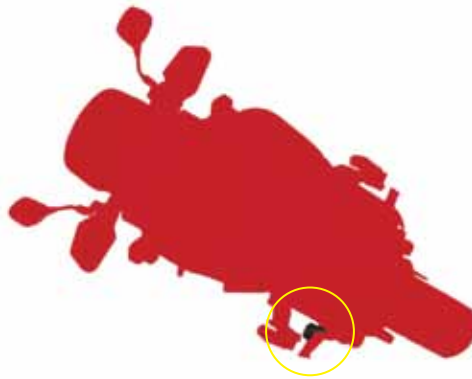
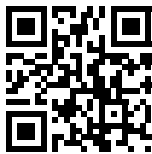

Does not limit maximum lean angle

Starting At
\$149⁹⁹

Suzuki DL1000 V-Strom
HPS.05.159.100



Foot lever provides excellent leverage



Optimal clearance for cornering



Spring Puller Tool for easy install
WFF.00.138.100: \$32.99



MSS.07.707.10000.S



KLR650 centerstand lifting handle (all years)



Aluminum Skid Plates

Our engine guards are constructed from laser-cut, TIG-welded aluminum and provide heavy-duty protection from stone chips, underside stump collisions, and other ride-ending calamities.

Most skid plates feature:

- Oil drain plug access hole.
- Rubber mounting to minimize noise and vibration.
- Recessed mounting bolts to prevent damage against rocks and stumps.
- Riveted construction.
- 4mm bottom plate and 3mm side plate that overlaps for a total of 7mm of side rail thickness.



'12 Suzuki DL650 V-Strom
MSS.05.759.10000.B

Also available:
'04-'11 Suzuki DL650 V-Strom
MSS.05.296.10001.B

Starting At
\$129⁹⁹

See the "What Fits My Bike?" section of the catalog (pages 156-227) for bike-specific skid plate information.



Yamaha XT1200Z Super Tenere, '10 and later

MSS.06.150.10000.S

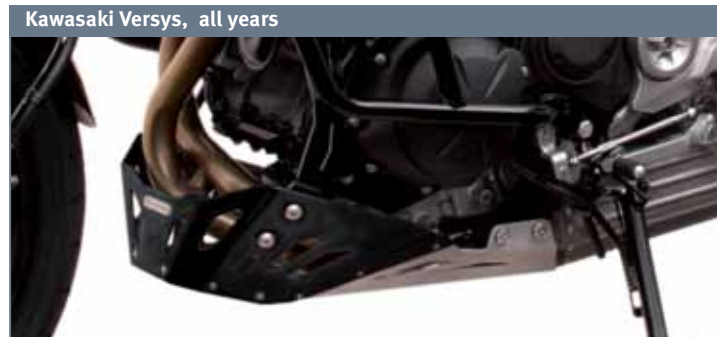

Kawasaki Versys, all years

MSS.08.712.10000.B



Ducati Multistrada 1200, '10 and later

MSS.22.143.10000.S



BMW R1200GS, '06 and later & R1200GS Adventure, '08 and later

MSS.07.706.10000.S



Triumph Tiger 800 & 800XC, '11 and later

MSS.11.752.10000.B



Kawasaki KLR650E, '08 and later

MSS.08.347.10001

Rear Brake Guards & Sidestand Feet



Most models
\$34⁹⁹

Rear Brake Master Cylinder Guards

SW-MOTECH rear brake master cylinder guards protect your master cylinder from flying rocks and damage from the heel of your boot.

BMW R1200GS Rear Brake Master Cylinder Guard



BPS.07.175.10000.S

BMW	Notes	Part Number
R1200GS, '08-'12	Silver.	BPS.07.175.10000.S
F800GS, '08-'12	Silver.	BPS.07.175.10100.S
F650GS twin, '08-'12	Silver.	BPS.07.175.10100.S
F650GS single, '07	Silver.	BPS.07.175.10100.S
G650GS, '09-'12	Silver.	BPS.07.175.10100.S
Kawasaki	Notes	Part Number
KLR650, '87-'12	Black or silver.	GRD.00.804.10000
Suzuki	Notes	Part Number
DL650 V-Strom, '04-'12	Silver.	BPS.05.175.10000.S
Triumph	Notes	Part Number
Tiger 800 & 800XC, '10-'12	Silver.	SCT.11.174.10100/S

Sidestand Feet

SW-MOTECH sidestand foot enlargers mount to your original sidestand to provide a wider, more stable platform for your motorcycle. Unlike other brands with sharp, serrated sheet metal designs, our rounded, machined billet aluminum designs won't cut your riding pants or scrape up your boots. Black mount with silver foot.

BMW R1200GS Sidestand Foot Enlarger



STS.07.102.10000.S

Most models
\$49⁹⁹

Most models
\$35⁵⁰

Rear Brake Reservoir Guards

SW-MOTECH rear brake reservoir guards provide protection to this vital part while adding rugged style.

Triumph Tiger 800 & Tiger XC 800



BMW	Part Number
R1200GS, '08-'12	SCT.07.174.10300.S
F650GS twin, '08-'12	SCT.07.174.10100.S
F800GS, '08-'12	SCT.07.174.10100.S
Kawasaki	Part Number
Versys 650	In development
Triumph	Part Number
Tiger 800 & 800XC	SCT.11.174.10000.S

Regulator and Potentiometer Guards

BMW F800GS/F650GS Regulator Guard



Mounts on the right side of the '08-'12 F650GS twin & F800GS. SCT.07.174.10000.S

BMW R1200GS Potentiometer Guard



Mounts behind the left side cylinder to protect the potentiometer of the '08-'12 BMW R1200GS. SCT.07.174.10200.S

BMW	Part Number
G650GS single, '09-'12	STS.07.102.10200.S
F650GS single, '07	STS.07.102.10200.S
F650GS twin, '08-'12	STS.07.102.10100.S
F800GS, '08-'12	STS.07.102.10100.S
R1200GS, all years	STS.07.102.10000.S
Kawasaki	Part Number
Versys 650	In development
KTM	Part Number
LC8 Adventure 990, '06-'12	STS.04.102.10000.S
Suzuki	Part Number
DL650 V-Strom, '04-'12	STS.05.102.10000.S



Starting at
\$68⁰⁰

Radiator and Oil Cooler Guards

Protect your radiator from rocks, bugs, and other UFOs. SW-MOTECH and R&G radiator guards and oil cooler guards improve the looks of your bike and help to protect your expensive and vulnerable radiator and oil cooler from flying debris. Instructions and all mounting hardware are included. No drilling, welding, zip ties or duct tape needed.

Radiator Guards				
Aprilia	from	to	Notes	Part No.
Tuono	'11	'12	Radiator Guard	RG.RAD0109
RSV4	'08	'11	Radiator Guard	RG.RAD0076
Dorsoduro 1200	'11	'12	Radiator Guard	RG.RAD0107
BMW	from	to	Notes	Part No.
S1000RR	'09	'12	Radiator Guard	RG.RAD0087
R1200GS	'09	'12	Oil Cooler Guard	KLS.07.719.10000.B
Ducati	from	to	Notes	Part No.
Multistrada 1200	'10	'12	Radiator Guard	RG.RAD0092
Streetfighter 1098	'09	'12	Radiator & Oil Cooler Guard	RG.RAD9016
Honda	from	to	Notes	Part No.
CBR1000RR	'08	'12	Radiator Guard	RG.RAD0065
CBR600RR	'07	'09	Radiator Guard	RG.RAD0077
VFR1200F	'10	'12	Radiator Guard (manual clutch)	RG.RAD0089
VFR1200F	'10	'12	Radiator Guard (auto clutch)	RG.RAD0097
Kawasaki	from	to	Notes	Part No.
GTR1400 Concours	'07	'12	Radiator Guard	RG.RAD0080
ZX-14	'06	'12	Radiator Guard	RG.RAD0080
Z1000	'10	'12	Radiator Guard	RG.RAD0090
Z750	'07	'12	Radiator Guard	RG.RAD0090
Versys	'10	'12	Radiator Guard	RG.RAD0091
ZX6R	'07	'12	Radiator Guard	RG.RAD0078
ZX10R	'08	'12	Radiator Guard	RG.RAD0068
KLX250S / SF	'05	'12	Radiator Guard	KLS.08.426.10000.S
KTM	from	to	Notes	Part No.
LC8 Adventure 990	'06	'12	Radiator Guard	KLS.04.389.100
LC8 Adventure 950	'03	'05	Radiator Guard	KLS.04.389.100
Suzuki	from	to	Notes	Part No.
DL650 V-Strom	'04	'11	Radiator Guard	RG.RAD0112
Gladius	'09	'12	Radiator Guard	RG.RAD0074
GSX1250FA	'07	'12	Radiator Guard	RG.RAD0093
GSX-R 600	'06	'12	Radiator Guard	RG.RAD0066
GSX-R 750	'04	'12	Radiator Guard	RG.RAD0066
GSX-R 1000 K7-K8	'04	'09	Radiator Guard	RG.RAD0069
GSX-R1000 K9-	'09	'12	Radiator Guard	RG.RAD0084
Hayabusa & B-King	'08	'12	Radiator Guard	RG.RAD0086
Triumph	from	to	Notes	Part No.
Street Triple	'07	'12	Radiator Guard	RG.RAD0070
Speed Triple	'06	'09	Radiator & Oil Cooler Guard	RG.RAD0083
Speed Triple	'10	'12	Radiator & Oil Cooler Guard	RG.RAD0098
Speed Triple	'11	'12	Radiator Guard	RG.RAD0099
Tiger 800	'11	'12	Radiator & Oil Cooler Guard	RG.RAD0101
Tiger 1050	'07	'12	Radiator & Oil Cooler Guard	RG.RAD0073
Yamaha	from	to	Notes	Part No.
FZ-8	'10	'12	Radiator Guard -	RG.RAD0094
YZF-R6	'06	'09	Radiator Guard -	RG.RAD0067
YZF-R1	'04	'06	Radiator Guard -	RG.RAD0072
YZF-R1	'07	'08	Radiator Guard -	RG.RAD0067
YZF-R1	'09	'12	Radiator Guard -	RG.RAD0071
XT1200Z Super Tenere	'11	'12	Downpipe Grill	RG.DG0001

Suzuki V-Strom DL650 '04-'11



Kawasaki KLX250X/F



Triumph Street Triple



Handlebar Risers & Conversion Kits

Handlebar Riser on Ducati Multistrada 1200



LEH.22.039.10000

Handlebar risers

Handlebar risers change the position of the handlebar for greater comfort during long rides. Handlebar riser kits are CNC-milled from billet aluminum or die cast. All required mounting hardware included.

Most models

\$57 to \$119

Universal Handlebar Risers



LEH.00.039.150

Traditional handlebar risers

move the handlebar straight up from its original position and are available in heights ranging from 20mm (0.8") to 50mm (2"). Available for 22mm and 28mm diameter bars.

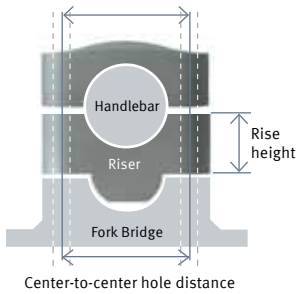

Handlebar Conversion Kits



LEH.00.039.160

Handlebar conversion kits

combine a 20mm riser with the ability to use a 28mm diameter "fatbar" on a bike that originally used 22mm diameter handlebars.

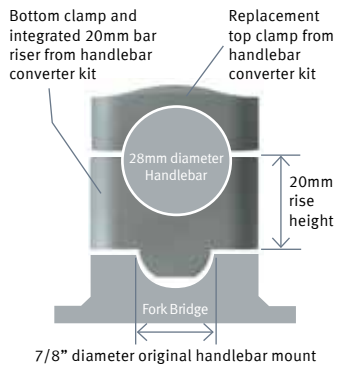

Universal handlebar risers		
For 7/8" (22mm) diameter bars	Notes	Part Number
20mm (0.8") rise	Fits hole distances 32-38mm w/ M8 bolts. Black or Silver	LEH.00.039150.20
25mm (1.0") rise	Fits hole distances 32-38mm w/ M8 bolts. Black or Silver	LEH.00.039150.25
30mm (1.2") rise	Fits hole distances 32-38mm w/ M8 bolts. Black or Silver	LEH.00.039150.30
50mm (2.0") rise	Fits hole distances 32-38mm w/ M8 bolts. Black or Silver	LEH.00.039150.50
31mm (1.25 ") up and 22mm (7/8") back	Fits hole distances 32-38mm w/ M8 bolts. Black or Silver	LEH.00.039.152
For 1.125" (28mm) diameter bar	Notes	Part Number
30mm (1.2") rise	Fits hole distances 37-46mm w/ M8 bolts. Black or Silver	LEH.00.039.20300
30mm (1.25 ") up and 22mm (7/8") back	Fits hole distances 37-46mm w/ M8 bolts. Black or Silver	LEH.00.039.20000

Bike-specific handlebar risers		
BMW	Notes	Part Number
F650GS & F650GS/Dakar (2000-2007) G650GS (2009 & Later)	20mm (0.8") rise. Silver.	BB.B55
F650GS (2008 & Later) & F800GS (2008 & Later)	20mm (0.8") rise. Silver.	LEH.07.039118.20.S
F800GS (2008 & Later)	30mm (1.2") rise. Silver.	LEH.07.039118.30.S
R1200RT (2005 & Later)	25mm (1") rise and angled toward rider. Silver.	LEH.07.039.12301.S
R1200GS & R1200GS Adventure (2007 & Earlier)	30mm (1.2") rise. Black.	LEH.07.039.111
R1200GS & R1200GS Adventure (2008 & Later) & HP2 Enduro	30mm (1.2") rise. Silver.	LEH.07.039.117.S
R1200GS (2008 & Later)	20mm (0.8") rise, 30mm (1.2") back. Silver.	LEH.07.039.12200.S
Buell	Notes	Part Number
XB12X Ulysses, Blast, XB9/XB12 Lightning	Moves bars 2" closer to rider	ROX.3R-P2SSM
Ducati	Notes	Part Number
Monster 620, 695, 750, & 900 (2002 & Later)	For 7/8" dia. bars with 38mm hole space. 33mm rise. Silver or black	GM.D103
Monster S2R (2005 & Later), S4R (2003 & Later) & Multistrada 1100 (2007 & Later)	For 28mm dia. bars with 38mm hole space. 33mm rise. Silver	GM.D100
Multistrada 1200 (2010 & Later)	30mm (1.2") rise. Black.	LEH.22.039.10000.B
Honda	Notes	Part Number
CBR1100XX Blackbird (1997 & Later) & VFR800 VTEC (2002 & Later)	19mm (0.7") rise. Silver.	GM.H112
CBR600F4i (1999 & Later)	For models with 43mm dia. fork tubes. 19mm rise. Silver.	GM.H120
Shadow, Valkyrie, Magna, & Pacific Coast PC800	25mm (1.0") rise. Silver.	GM.H121
ST1300	Up 32mm (1.3") and back 25mm (1.0"). Silver.	GM.H101
VFR800 (1998-2001)	19mm (0.7") rise. Silver.	GM.H117
VTX1300	For models with tubular handlebars. 1" rise. Silver.	GM.H121
Kawasaki	Notes	Part Number
Concours GTR1000 / ZG1000 (1994-2007)	32mm (1.3") rise. Black.	GM.K105
Concours GTR1400 (2008 & Later)	Up 38mm (1.5") and back 22mm (0.9"). Silver	GM.K405
Mean Streak	Up 2" and back 1-1/8". Chrome.	GM.X12
Ninja 250R (2007 & Earlier)	Up 38mm (1.5") and back 19mm (0.8"). Black.	GM.K108
Ninja 500R	38mm (1.5") rise. Black.	GM.K107
Ninja 650R / ER6-N (2009 & Later)	20mm (0.8") rise. Black.	LEH.08.039.120.B
Versys (2007-on)	18mm (0.7") rise. Silver.	LEH.08.039.119.S
ZZR600 (2003-2004) ZX6E (1993-2002) ZX6D (1990-1992)	25mm (1.0") rise. Black.	GM.K109



Kawasaki Versys (2007 and later)

LEH.08.039.119.S



BMW R1200GS (2008 and later)

LEH.07.039.12200.S



Triumph Tiger 800 & 800XC (2011 and later)

LEH.11.039.10000.S



BMW R1200RT (2005 and later)

LEH.07.039.12300.S



BMW R1200GS (2007 and earlier)

LEH.07.039.111.B



Yamaha XT1200Z Super Tenere (2010 and later)

LEH.06.039.10100.S

Kawasaki (continued)	Notes	Part Number
Z750, Z750S, & Z1000 ('07-'09)	Up 38mm (1.5") and back 25mm (1.0"). Black.	LEH.08.039.12100.B
ZZR1200	32mm (1.26") rise. Silver.	GM.K102
ZX-14	Up 25mm (1.0") and back 16mm. Black.	GM.K115
KTM	Notes	Part Number
KTM LC4 with 28mm dia. handlebar	For models with MAGURA or ProTaper handlebars. 30mm (1.2") rise. Silver.	LEH.00.039.101
KTM LC8 Supermoto & Super Enduro 950/990	30mm (1.2") rise. Silver.	LEH.00.039.106
KTM LC4 Adventure, 2001 & Later	30mm (1.2") rise. Silver.	LEH.00.039.106
KTM LC8 Adventure 950/990	30mm (1.2") rise. Silver.	LEH.00.039.106
KTM EXC (all years) & LC4 SuperComp (2000 & Later)	30mm (1.2") rise. Silver.	LEH.00.039.110
Suzuki	Notes	Part Number
GSX1300R Hayabusa (1999-2007)	1.25" rise. Black.	GM.S123
GSX1340R Hayabusa (2008 & Later)	1.25" rise. Black.	GM.S223
GSX1340R Hayabusa (2008 & Later)	0.75" rise. Black.	GM.S222
Intruder & Intruder Volusia Boulevard C50, C90, S40, S83, S90	For most models with 1" dia. tubular bars. Up 1.5" and back 1". Chrome.	GM.S126
Boulevard C90 & some Intruder models	For models with 1" dia. tubular handlebars. Up 1.5" and back 1". Silver.	GM.S130
Volusia models w/ one-piece handlebar & original riser	Up 2" and back 1-1/8". Chrome.	GM.X12
Triumph	Notes	Part Number
Bonneville	Up 1.25" and back 0.75". Silver.	GM.T114
Sprint RS (2004-2005)	Up 1-1/8" and back 0.75". Silver.	GM.T119
Sprint ST 1050 (2005 & Later) & Sprint ST 955 (2001-2004), RS (2000-2003)	1.25" rise. Silver.	GM.T118
Street Triple 675 (2007-2010) Speed Triple 1050 (2005-2007)	22mm riser.	LEH.00.039150
Street Triple 675 (2007-2010) Speed Triple 1050 (2005-2007)	22mm barback.	LEH.00.039.152
Street Triple R 675 & Speed Triple 1050 (2008 & Later)	28mm.	LEH.00.039.20300
Tiger 800 & 800XC	20mm (0.8") rise. Silver.	LEH.11.039.10000.S
Tiger 1050	Replaces stock handlebar to 28mm handlebar with 45mm rise (from original position). For use with Barkbusters VPS Handguards. See page 12.	BB.VSB-BC
Yamaha	Notes	Part Number
FJR1300 (2001-2005)	Up 25mm & toward rider at 15-degree angle. Silver.	LEH.06.039.114.S
FJR1300 (2006 & Later)	Up 25mm & back 13mm. Silver.	GM.Y203
V-Max 1200 (2008 & Later)	Up 1" and back 1.25". Brushed aluminum or powdercoated black.	GM.Y124
XT1200Z Super Tenere	Up 25mm. Silver	LEH.06.039.10100
YZF600R Thundercat (1996-2007)	19mm (0.7") rise. Silver with black trim.	GM.Y119

Universal Up & Back Handlebar Riser



22mm: LEH.00.039.152

28mm: LEH.00.039.20000

Up-and-back risers move the handlebar both upwards and rearward towards the rider.

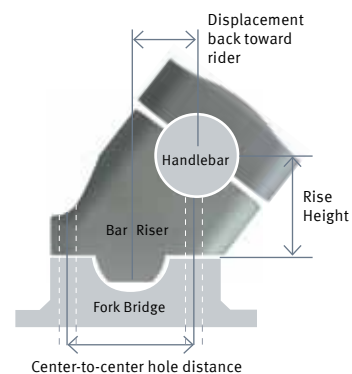

See more photos of our handlebar risers at twistedthrottle.com

ULTIMATE PROTECTION **Barkbusters** HANDGUARDS

The ORIGINAL Motorcycle Handguard! The Barkbusters brand of handguards was first manufactured in 1984. With over 28 years of motorcycle industry experience and an enthusiasm for riding motorcycles, the people at Barkbusters know what it takes to develop the finest handguards available on the market today.

Barkbusters integrates a hardened aluminum backbone with a stylish, replaceable plastic guard to create a truly functional handguard. No more busted levers or knuckles! In the unlikely event that you break a part of the handguard, every piece is replaceable.

These are the toughest handguards anywhere – they don't call 'em Barkbusters for nothing!

Barkbusters handguards are designed to work with Kaoko throttle locks (See page 16-17).



Barkbusters VPS Full-Wrap Supermoto and Adventure Bike Handguards

Versatile full-wrap handguards that blend heavy-duty obstacle armor with moderate weather protection.

VPS (Variable Protection System) Handguards are designed for **bikes with long brake and clutch levers**, including most street and adventure-touring bikes. The hardened aluminum backbone prevents damage to your levers in case of a tip-over and has a relatively compact profile appropriate for trail riding.

Available with black, blue, green, red, yellow, silver, orange, white or pink plastics. A **Variable Height Wind Deflector** is included to provide extra wind protection. See pages 14-15 for fitting information.



Barkbusters VPS-MX Single-Sided Motocross Handguards

Single-sided handguards for competition motocross use.

Barkbusters VPS-MX handguards use VPS plastics on a **single-sided mount**, providing a lightweight handguard that meets competition motocross regulations.

This handguard comes with an easy to install, clamp-on mounting kit that fits all 7/8" diameter handlebars. The handguard allows plenty of clearance for bikes with longer levers. The design incorporates high impact nylon brackets to firmly support the plastic VPS guard. The handguard position can easily be adjusted.

Available with black, blue, green, red, yellow, silver, orange, white or pink plastics.

Variable Height Wind Deflector

These optional variable height wind deflectors can be installed to provide extra wind protection. Available in black or white only. **BB.BHG4: \$15.00**



Barkbusters Ego Enduro and MX Handguards

Ultra-compact full-wrap handguards ideal for tight off-road trail use.

Ego handguards are the smallest full-wrap handguards made by Barkbusters. They are specifically designed for enduro and MX bikes with **short levers**. Their compact design helps you avoid hitting trees during intense trail riding.

Available with black, blue, green, orange, red, white or yellow plastics. See pages 14-15 for fitting information.



Barkbusters Storm Street and Adventure Bike Handguards

Maximum wind and rain protection for street and adventure-touring bikes!

Storm handguards have an aerodynamic design and a larger profile that wraps around the hands to offer excellent wind and weather protection. The wide profile is great for street riding and open trails, but is less suited for tight off-road, single track use.

Storm handguards are available in single-point and full-wrap mounting styles. Single-point mounting styles provide the cleanest look and easiest installation on street motorcycles. Full-wrap mounting styles connect to your handlebar at two points and are recommended for maximum strength on dual-sport and adventure touring bikes.

Available with black or chrome plastics. Chrome plastics are not recommended for off road use.

Storm



Storm Handguards are available in three mount styles:



Storm Full-Wrap Backbone

Two mounting points make this the strongest backbone available.

BB.S4
from: **\$98.00**



Storm Open-ended Backbone

Designed specifically for street bikes and mounted to a single point on the handlebars.

BB.S1
Fits 7/8" diameter bars
BB.S2
Fits 1" diameter handlebars

from: **\$109.99**



Storm Bar End Mount Backbone

This aluminum frame mounts to the end of the handlebar. Ideal for bikes without space on the handlebar or other mounting methods.

BB.S5
Fits hollow 7/8" or 1" diameter handlebars
BB.S7
Fits bar ends with a 6mm or 8mm threaded hole

from: **\$109.99**

See pages 14-15 to find mounting hardware that fits your bike.

Optional Accessories

VPS Variable Height Wind Deflector (included with Full-Wrap VPS handguards)

These optional variable-height wind deflectors provide extra wind protection. Available in black or white only.

For VPS & VPS-MX Handguards only.
BB.BHG4: \$15.00



VPS skid plates

These optional replaceable skid plates protect the outer end of the backbone during a tipover or low side. Perfect for Supermoto bikes. For VPS guards only.

BB.BHG2: \$15.00



Barkbusters Bar End Weights

Add 180 grams of mass to each end of your handlebars to reduce vibration.

Compatible with full-wrap Storm and VPS Handguards.

BB.B66 \$45.00

Training Bike Handguards

NEW

NEW! Barkbusters handguards for training bikes. Finally, a solution to the problem of damaged levers after a student drops a training bike. Any motorcycle safety instructor can tell you just how common this problem is. Not only do these handguards protect levers from costly and time-consuming repairs, but they protect the student's hands in the process. Discounted fleet pricing available for motorcycle training schools.

BB.BLG5: Fits Suzuki GZ250
BB.BLG6: Fits Kawasaki BN125 Eliminator
BB.BLG7: Fits Suzuki TU250
\$79.99 per set



ULTIMATE PROTECTION
Barkbusters
 HANDGUARDS



Barkbusters Handguards

Below are the bike-specific kits for the VPS, EGO, and Storm handguards.

Storm



VPS



EGO



How to Order Barkbusters Handguards: Follow the 4-step process for selecting the exact handguard you want.

STEP 1

FIND your bike in the Application Chart

If your bike is not listed, or you've installed aftermarket handlebars on your bike, see the aftermarket handlebar application chart at the end of the next page for fitting information.

STEP 2

ORDER chosen Guard, Mounting Kit, and any Extra Parts

Determine what handguards are available for your bike. If there is a **part number** in the **Storm, VPS, or EGO** column next to your bike model, that style is available for your bike. Order using that part number, **plus** any "mounting kit" or "extra parts" listed for that bike.

STEP 3

CHOOSE Plastics Color

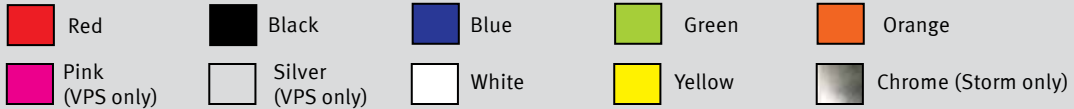

STEP 4

CHOOSE Optional Accessories

Bar end weights, VPS Wind Deflectors, or VPS skid plates (from previous page).

BMW	GUARD			Mounting Kit	Extra Parts
	Storm	VPS	EGO		
F650GS/Dakar, '07-	BHG10	BHG10		Included	
F650GS (Twin), F800GS, '08-	BHG32	BHG32		Included	
F650CS Scarver	S1			Included	
F800R, F800S	S7			Included	
G450X		BHG1	ES2	BTC.01	1x B54
G650GS, '09-'10	BHG10	BHG10		Included	
G650GS, '11-	BHG45	BHG45		Included	
G650X Challenge/Moto/Country	BHG13	BHG13		Included	
HP2 Enduro, '07-'09		BHG1		BTC.02	1x B54
HP2 Megamoto, '07-'09	BHG32	BHG32		Included	
K1200GT, K1300GT	S7			Included	
R100GS (without OEM heated grips)	BHG45	BHG45		Included	
R1100GS, & R1150 GS Adv	BHG20	BHG20		Included	
R1100RS, R1150 R, R1150RS	S7			Included	
R1200R	S1			Included	
R1200RT	S7			Included	
R1200GS, '04-'11	BHG32	BHG32		Included	
R1200GS Adventure '06-'11	BHG32	BHG32		Included	
Buell	Storm	VPS	EGO	Mounting Kit	Extra Parts
Ulysses	S4	BHG1		BSC.STD	
Can Am	Storm	VPS	EGO	Mounting Kit	Extra Parts
Spyder	S5			Included	

Ducati	GUARD			Mounting Kit	Extra Parts
	Storm	VPS	EGO		
Multistrada 1000DS	S1			Included	
Multistrada 1000DS	S5			Included	
Multistrada 1000DS	S4			BSC.STD	
Multistrada with 22mm handlebar	S1 or S5			Included	
Multistrada with 22mm cross-brace type handlebar	S4			BSC.STD	
Multistrada with tapered handlebar	S1 or S5			Included	
Multistrada 1200		BLG-12		Included	
Monster 1000 S4RS (all)	S5			Included	
Honda	Storm	VPS	EGO	Mounting Kit	Extra Parts
CR 80R/ CR 85R		BHG7	ES4	Included	
CRF 150 R, F, EXPERT		BHG7	ES4	Included	
CRF 230 F, L, CRF 250 R, X		BHG1		BSC.STD	
CRF 450 R, X		BHG1	ES2	BSC.STD	
CB 1000R (ABS), -'09	S5			Included	
CB 1000R (Non ABS), -'09	S1			Included	
CBF600S, CBF 1000, -'09	S1			Included	
XR 250, XR 400		BHG1		BSC.STD	
XR 650 L, XR 650 R	S4	BHG1		BSC.STD	
XL1000V Varadero	BHG31	BHG31		Included	
Husqvarna	Storm	VPS	EGO	Mounting Kit	Extra Parts
All SM, WR & TE models with 22m (7/8th) Tommaselli bars		BHG1	ES2	BSC.STD	B29
All SM, WR & TE models with Tapered handlebars		BHG1	ES2	BTC.01	B25

Husqvarna continued	GUARD				Mounting Kit	Extra Parts
	Storm	VPS	EGO			
All CR & TC models		BHG7		Included		
All 2010 models with Magura handlebar		BHG1	ES2	BTC.01		
Kawasaki	Storm	VPS	EGO	Mounting Kit	Extra Parts	
KX65, KX80, KX85, KLX110		BHG7	ES4	Included		
KLX 100			ES4	Included		
KX125, KX250, KX50F, KX450F		BHG7		Included		
KLX 450, '08-on		BHG1	ES2	BSC.STD		
KLX 250, '86-'06 KLX 250A, '86-'07, KLX 250S	S4	BHG1		BSC.STD		
KLR650, all	BHG15-01	BHG15-01		BSC.STD		
Z750	S7			Included		
Ninja 650R, '09-, Z1000, '04-'06	S1			Included		
ER-6N/ABS, '09-, Z1000 (all)	S7			Included		
Super Sherpa	S4	BHG1		BSC.STD		
Versys	BHG15-01	BHG15-01		Included Included		
KTM	Storm	VPS	EGO	Mounting Kit	Extra Parts	
690 Enduro/R	S4	BHG1		BTC.02		
SX (ALL)		BHG7		Included		
EXC and LC4 Models with Rental bars	S4	BHG1	ES2	BTC.02	1 x B54	
EXC and LC4 Models with Magura bars	S4	BHG1	ES2	BTC.01		
950-990 Adventure, '05-'09	S4	BHG1		BTC.02		
2010 models with NEKEN bars		BHG1	ES2	BTC.03.2	1 x B54	
Moto Guzzi	Storm	VPS	EGO	Mounting Kit	Extra Parts	
Stelvio	BHG33	BHG33		Included		
Suzuki	Storm	VPS	EGO	Mounting Kit	Extra Parts	
RM80, RM85, RM85 L		BHG7		Included		
RM / RM-Z250 RM-Z450		BHG7		Included		
DR 400 E, DR 650SE	S4	BHG1		BSC.STD		
DR-Z400S, DR-Z400SM	S4	BHG1	ES2	BSC.STD		
DR-Z400SM Fat Bar	S4	BHG1		BTC.02		
DL650 & DL1000 V-Strom	BHG44	BHG44		Included		
GS500E, '89-, GSF 650N Bandit, '05-	S1			Included		
GSF 1250N/ S	S1			Included		
SV650, '99-'08, SV1000, '03-'08	S1			Included		
GSX650F, GSX1400, '01-'08, Gladius 650, '09-	S1			Included		
Burgman 400cc	S5			Included		
B-King	S5			Included		
Triumph	Storm	VPS	EGO	Mounting Kit	Extra Parts	
Street Triple, Speed Triple	S7			Included		
Tiger 800	BHG43	BHG43		Included		
Tiger 955i, Tiger 1050	S1 or S7			Included		
Tiger 1050 with VSB 28mm handlebar	BHG23	BHG23		Included	BB.VSB-BC	
Rocket 3	S7			Included		
Scrambler	S1			Included		
Sprint RS	S7			Included		
Bonneville SE, '09-'10	S1			Included		
Yamaha	Storm	VPS	EGO	Mounting Kit	Extra Parts	
FZ6-Fazer, '06-'09	S1			Included		
FZ1-N	S1 or S7			Included		
FZ1/FZ1S, '06-'10	S1			Included		
FJR1300	S7			Included		
YZ125, YZ250, YZ250F, YZ450F		BHG7		Included		
WR250F, '06		BHG1	ES2	BSC.STD		
WR250F, '07-on		BHG1	ES2	BTC.02		

Yamaha continued	GUARD				Mounting Kit	Extra Parts
	Storm	VPS	EGO			
WR250R, WR250X, WR400		BHG1	ES2	BSC.STD		
WR450F, '06		BHG1	ES2	BSC.STD		
WR450F, '07-		BHG1	ES2	BTC.02		
TW200, XT 250		BHG1	ES2	BSC.STD		
XT600, XT660	S4	BHG1		BSC.STD		
XT1200Z Super Tenere	BHG40	BHG40		Included		
XVS650	S5			Included		
XVS950, XV1600	S2			Included		



Aftermarket handlebar application chart

ORDER Barkbusters full-wrap handguards for unlisted bikes or aftermarket handlebars.

What to Order:

- STEP 1** Order the backbone for handguard style.
BB.ES14 backbone for EGO handguards
BB.BHG1 backbone for VPS or Storm handguards
- STEP 2** Find your handlebar in the chart below and order the corresponding "mounting kit" and "extra parts" listed.
- STEP 3** Choose plastics color from chart on previous page.
- STEP 4** Choose optional accessories.
Bar end weights or VPS skid plates shown on page 13.

Handlebar type	Full-wrap Mounting Kits
22mm (7/8") hollow-tube handlebars with a 14mm or 18mm Inside Diameter (ID)	BB.BSC.STD
Acerbis PHS Evol	BB.BTC.06
Barkbusters VSB	BB.BTC.00
Fly (high bend)	BB.BTC.01
Fly AERO (not high bend)	BB.BTC.00
Fly AERO McFly	BB.BTC.06
Fly Mini Bars	BB.BTC.06
G-YTR	BB.BTC.06
Hebo	BB.BTC.06
Magura	BB.BTC.01
Pazzaz	BB.BTC.00
Pro Taper Contour	BB.BTC.06
Pro Taper Easton	BB.BTC.06
Reikon DSC	BB.BSC.STD
Reikon Taper	BB.BTC.06
Rental Fat Bar	BB.BTC.06
Rental Twin Wall	BB.BTC.00
Star Booster Bar	BB.BTC.01
Tag T2 (most models)	BB.BTC.06
Universal Mounting Kit for VPS plastic guard	BHG7-UMK
2009 Tag T2 models with codes 7221, 9661, 9711, 6091, 7901, 7841	BB.BTC.06
Extra Parts (may be required for some applications)	
Triple clamp mount (fits most bikes, not KTM or Husaberg)	BB.TCM
Angled swivel clamp (replaces clutch-side straight swivel clamp on KTM models with Magura or Rental handlebars AND Brembo clutch activators)	BB.B54



KAOKO
Cruise Controls

Kaoko™ Cruise Control Kits

Relieve fatigue and strain on your hand and wrist by locking the throttle mechanism in place. Operation is simple and smooth through the use of a knurled friction adjustment ring. The rider simply sets the throttle and rotates the friction adjustment ring to lock at the desired throttle opening.

For most models, Kaoko designs their bar end weight to match the appearance and weight of the original OEM bar end weight.

To install, just remove the original right hand bar weight, replace it with Kaoko's bar weight, and firmly tighten the central retaining screw.

- Reduces strain on hand and wrist
- While cruising, the rider can relax or remove the throttle hand from the grip and the throttle will remain as set.
- Very simple to operate, even with heavy winter gloves.
- Takes less than 5 minutes to install.

Starting At
\$120⁰⁰

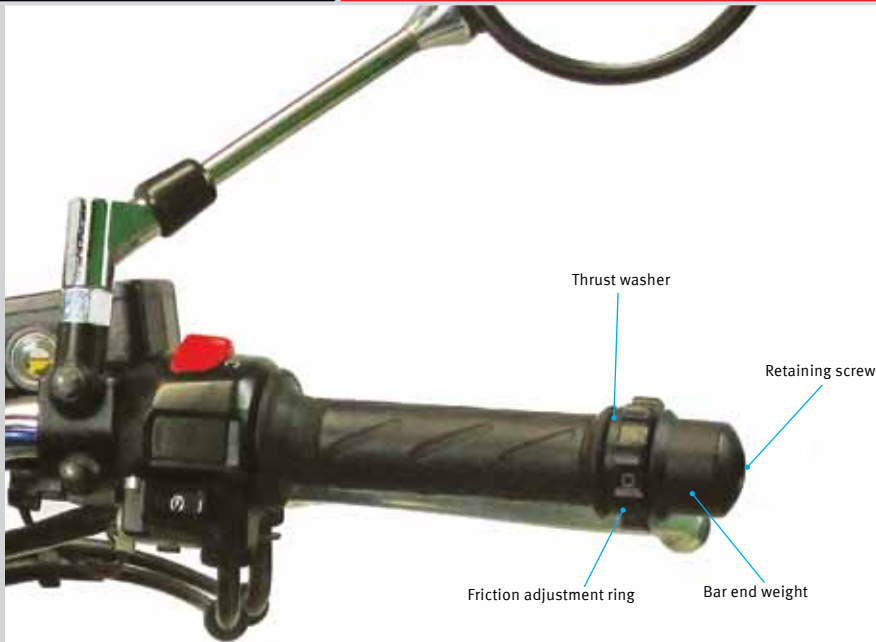

Suzuki SV650N
KAO.SUZ100



See the Video:
Kaoko Throttle
Lock and Barkbusters
handguard compatibility.



Ducati 1098 with KAO.DUC100 installed



Cruise Control for Harley Davidson motorcycles

Compatible with Barkbusters handguards!



Kaoko cruise controls can be used with many original and aftermarket full-wrap hand guards, as well as all open-ended handguards, including Barkbusters Storm (S1, S2, and S7 only) and VPS-MX models.

See pages 12-15 for information on Barkbusters Handguards.

See the next page for information on which throttle locks can be used with handguards on your bike.



BMW F800GS with Kaoko & Barkbusters



Yamaha Super Tenere with Kaoko & Barkbusters

Aprilia	Part No.	Notes
ETV1000 Caponord	CAPO	2004-2006 models with handguards
Pegaso Trail 650 (2006-), SL750 Shiver ABS, Mana GT850	APR200	Fits models w/ M6 threaded insert in the end of the handle bar.
RSV1000R/RR/Factory (2008-), Mana 850, Tuono (2005-)	APR300	
Dorsoduro 750, Dorsoduro 1200	APR400	Fits with OEM handguards
RSV4R (2009-)	APR500	
BMW	Part No.	Notes
K1300GT, K1200GT, R1200RT (2005-2009), R1150GS, R1150GS Adv, R1150R, R1150RT, R1100GS, R1100R, R1100RT, R850GS, R850R	CCF100	Does not fit R1100RS, R1150RS, or K1200RS model. Fits w/ or w/o Barkbusters full-wrap handguards.
R1100S	CCF200	
G650X Country	APR300	
F650GS & F650GS/Dakar (-2007), G650GS (2009-)	CCF300U	Fits w/o heated grips, w/o w/o handguards.
F650GS & F650GS/Dakar (-2007), G650GS (2009-)	CCF300	Fits models w/ heated grips, w/ or w/o handguards.
HP2	KTMADHP2	
R1200GS & R1200GS Adventure R1200ST - 90mm retaining screw.	CCF400	Fits w/ or w/o Touratech or original BMW handguards.
R1200GS & R1200GS Adventure R1200ST - 80mm retaining screw.	CCF400-08	Fits w/ or w/o Touratech or original BMW handguards.
R1200GS & R1200GS Adventure R1200ST	KBB400	Fits w/ Barkbusters BHG8 or BHG12
K1300S, K1300R, K1200S, K1200R R1200S, R1200R, R1200RT (2010-)	CCF500	
F650GS/Dakar (-2008), G650GS single with heated grips	KBB500	For use with Barkbusters VPS & Storm handguards
F800S & F800ST	CCF600	Bar ends w/ countersunk screw. Black or chrome.
F650GS/Dakar (-2008) and G650GS single without heated grips	KBB600	For use with Barkbusters VPS & Storm handguards
F800S & F800ST	CCF800	2006 - models w/ cap screw in counterbored bar end weight
F800GS & F650GS (2008-) w/o handguards, F800R (2009-) w/o handguards	CCF700	fits w/ or w/o Touratech handguards & retrofitted original R1200GS handguards that wrap outside of bar weight.
F800GS & F650GS, (2008-) F800R (2009-)	KBB700	For use with Barkbusters full-wrap handguards BHG16 & BHG17.
F800R, F800GS & F650GS Twin (2008-) and R1200ST, R1200GS/Adventure (all)	KBB700-S	For use with Barkbusters full-wrap handguards BHG32.
F800GS & F650GS twin (2008-)	CCF900	Fits w/ original BMW handguards
S1000RR (2010-)	CCF110	
Buell	Part No.	Notes
Ulysses XB12X & XB12XT, Lightning XB12S, Firebolt XB12R	BUB*	with or without OEM handguards
Can-Am	Part No.	Notes
Spyder Roadster	CAN100	Fits original handlebar
Spyder Roadster	CAN100S	Fits w/ Custom Dynamics and No Magic Neon riser kits.
Ducati	Part No.	Notes
ST2, ST3, ST3S, ST4, Multistrada 1100 & 1100S, Monster S2, S2R, S4R, S4RS, 1000GT Sport Classic	DUCST	
748, 848, 916, 996, 998, 1098, 1198 Streetfighter /S, Monster 1100 ABS Multistrada 1200 /S	DUC100*	Fits handlebars w/ 16.8 mm ID bars only. w/ handguards where applicable.
Multistrada 1200 /S	DUC101	Barkbusters BLG12 handguards
848 EVO (2008-) Monster 796 (2010-)	DUC105*	Fits handlebars w/ 14mm internal diameter only. Black.
Honda	Part No.	Notes
Silverwing 600 (2008-)	HNDJFS	
NT700 Deauville (2009-)	HNDNT	
ST1300 Pan European	HNDST	Fits w/ or w/o heated grips
XL1000V Varadero, XR750 Africa Twin	HNDVARAOXF	Fits w/ or w/o Oxford heated grips
CBR1000RR Fireblade (2006-), CBR600RR (2006-), 599 (2006-), VFR1200F (2010-)	HND28	Fits most other Honda models w/ 28mm OD bar weights.
CBR1000RR (2006-), CBR600RR (2002-2007), 599, VFR1200 (2010-), CB600 Hornet, CB1000R, CBF1000F, CBF600, CB1300	HND30-17 & HND30-19	30mm OD bars with 17 or 19mm ID
VFR800 (2006-), CBR1100XX Blackbird, VFR1200 (2010)	HND31	Fits other Honda models w/ 31mm OD bar weights. Black or silver.
VTX1300, Shadow Spirit VT1100, ACE Deluxe VT750, VT1300CX, VT750C2B, VT750S, VT750C2 VLX Deluxe VT600, Rebel CMX250	TCH-0.8 *	Torpedo-style, chrome with or w/o ABS. Fits 22mm ID handlebars. Black available.
VTX1800, Shadow Sabre, Shadow Aero, Shadow American, VT1100T	TCH-0.75*	Torpedo-style, chrome w/ or w/o ABS. Fits 21mm ID bars.

* Models marked with an asterisk (*) include both a right-side throttle lock and matching left side equally-weighted handlebar weight. All other models include only a right-side throttle lock.

Kawasaki	Part No.	Notes
Vulcan cruisers	KAWT *	Torpedo-style, black or chrome
KLR650A (-2007)	SUZ100	Fits w/o handguards or w/ OEM single-sided handguards
KLR650A (-2007), DL650 V-Strom and DL1000 V-Strom	UNIKIT17-4	For use with Barkbusters full-wrap handguards only
Z1000 (2003-2009), Z750 & Z750S (-2010) ZZR1200 & ZZR1100, ZRX1200R	KAW100	Fits models with tapered bar end weights
Z1000 (2011) Ninja1000 (2011)	KAW150	Fits models with parallel 30mm OD bar end weights
Z1000 (2011) Ninja1000 (2011)	KAW160	Fits models with parallel 37.8mm OD bar end weights
Ninja 650R, ER6N, ER6F, ER5F, Versys, KLR650E, ZX12, ZX14, ZZR1400, GTR1400 Concours	KAW200	Fits w/ or w/o OEM heated grips.
KLR650E, Ninja 650R, ER6N, ER6F, ER5F, Versys	KBB300	Fits w/ Barkbusters full-wrap handguards only
Ninja 636, ZX-6R, ZX-7R, ZX9, ZX10, ZX10R (-2011)	KAW400*	Fits most Kawasaki models w/ 22mm or 30mm OD bar weight.
KTM	Part No.	Notes
690 Duke/R, 990 Super Duke /R, 690R/SMC Supermoto, 690SM, 690SMR, 990R/T Supermoto, 950SM, 950SMR, 990SM	KTM100	For non-handguard models with bar end weights.
1190 RC8/R	KTMRC	
690 Duke, 690SM, 690SMR, 690R/SMC Supermoto, 950SM & 950SMR, 990 Super Duke, 990R/T Supermoto 1190 RC8/R	KTMAD	Fits models w/ KTM handguards
690 Duke, 690SM, 690SMR, 690R/SMC Supermoto, 950SM & 950SMR, 990 Super Duke, 990R/T Supermoto, 1190 RC8/R	KBBAD	Fits w/ Barkbusters full-wrap handguards only
Kymco	Part No.	Notes
Xciting 500/I	KYM100	
Moto Guzzi	Part No.	Notes
Breva V1100, Breva V1200, Breva V850, Norge 1200	MOTOBRE	
Sport 1200 4V ABS, Stelvio 1200 & Stelvio NTX	APR300	
Suzuki	Part No.	Notes
B-King, Bandit GSF650, GSF600 (S & N) Bandit GSF1250, GSF1200 (S & N) GSX-R600, GSX-R750, GSX-R1000 SV650 (S & N), TL1000S & TL1000R	SUZ100*	
GSXF750 & GSX600F Katana, GSXF650 (2008-), GSX1300R Hayabusa (-2007)	SUZ200	
GSX1340R Hayabusa (2008-)	SUZ200-08	
SV1000 (S & N)	SUZ300	
AN650 Burgman, Deluxe and Executive Boulevard C109R (2008-)	SUZ400	Black or Chrome (SUZ400C)
Boulevard M109R	Various	See web site
Boulevard C90, C50, M50, Intruder VS800	SUZM109*	Big Barrel-style, chrome
DL650 & DL1000 V-Strom	SUZTC*	Torpedo-style, chrome
DL650 & DL1000 V-Strom	Various. See web site	Options to use heated grips, Barkbusters & OEM handguards
Triumph	Part No.	Notes
Tiger 800 & Tiger 800XC (2011-)	Various	Fits with OEM flat cylindrical bar end weight. w/ or w/o Barkbusters handguards
Tiger 955i (2001-)	TIG955	
Tiger 1050	TIG1050	Fits w/ or w/o OEM handguard
Sprint ST 1050, Sprint ST 955, Sprint RS 955, GT 105	TST1050	
Rocket III	TROCIII	Fits all Rocket variations
Scrambler 900, Bonneville SE w/ Mag Wheels (2010-)	SCRAM	
Bonneville, America, T100 & Speedmaster (2001-2012)	BONI	
ThruXton 900, Street Triple 675 (2008-)	THRUX	
Speed Triple 1050 (-2010)	SPTRIP	Does not fit Daytona 675
Speed Triple 1050 (2011-)	SPTRIP11	Does not fit Daytona 675
Thunderbird Storm 1600 (all)	Various	
Victory	Part No.	Notes
All 2007 models	HDTCV07-0.8*	Torpedo-style, chrome
All 2008 models	HDTCV08-0.8*	Torpedo-style, chrome
Yamaha	Part No.	Notes
Fazer 1 & FZ1 (-2010), Fazer 6 & FZ6, TDM850, TDM900, XJR1200, XJR1300, MT01	YAM300	Black or Silver
FJR1300 (2009-), R1 & R6 (2009-)	YAM500	
XT1200Z Super Tenere (2010-)	YAM630	Fits with OEM handguards and heated grips or Barkbusters BHG40 Hand Guards.
FZ8 & FZ8 ABS (2011-)	YAM640	
FZ1 & FZ1 ABS (2011-)	YAM650	
V-Max (2009-)	YAM700	
V-Star & Roadstar models (2004-) XSV950A, XSV1300A	YAMSTAR	
Roadliner & Stratoliner models XV1900 Midnight-Star	YAMLINER	



R&G Racing Products

R&G Racing offers a wide range of products to fit most modern sportbikes, including frame sliders, front axle sliders, bar end sliders, exhaust and tank protectors, and aluminum radiator guards.

R&G Racing sets the bar high when it comes to manufacturing innovative crash protection. Modern CNC machining, aircraft-grade metals and cooperative R&D testing with the California Superbike School and motorcycle insurance companies help R&G to produce the toughest, most functional sport bike protection on the planet.

R&G Racing also offers 11-position adjustable rearsets, toe chain guards and fender eliminator kits for many sportbike models.



Public Relations Manager
"Hollywood" Ken Condon

Frame Sliders

R&G constructs their frame sliders from heavy-duty machined steel and aluminum, low friction HDPE (high-density polyethylene), and a frame mount design that provides maximum support. R&G also uses special high-tensile steel mounting bolts that withstand the force imposed by the vast majority of crash situations. In the event of an extreme impact, these bolts are designed to bend rather than snap off and leave the bike completely unprotected. Bending is good, because it will continue to protect well after impact. You can inexpensively fix single-sided crash damage with the purchase of one-side "half kits". R&G frame sliders come in two styles, "Classic" and "Aero".

Starting At
\$96⁰⁰
per pair

Classic Style Frame Sliders

Traditional cylindrical shape

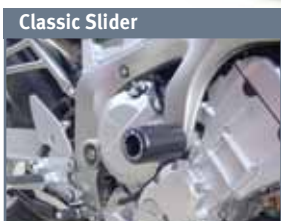

Classic Slider

Aero Style Frame Sliders

Starting At
\$105⁰⁰
per pair

Aerodynamic and stylish teardrop shape



Aero Slider - BMW S1000RR

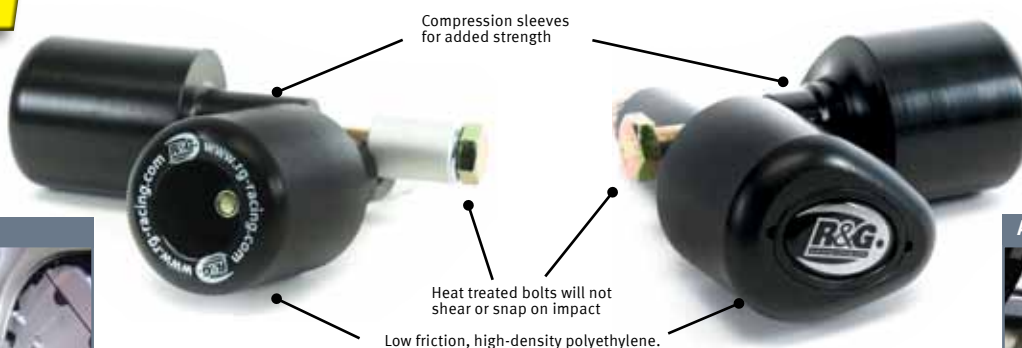

Compression sleeves for added strength

Heat treated bolts will not shear or snap on impact

Low friction, high-density polyethylene.

Cutting the fairing is required on some motorcycles. No-cut Frame Sliders are available for a growing number of models. See pages 156-227 for bike-specific applications or visit twistedthrottle.com for applications.

Underbody Sliders also available for some models.

These sliders sit just behind the fairing panels for support in the event of a crash. The fairing may be sacrificed, but the underbody slider provides better protection for the motorcycle frame and engine without the risk of the slider catching on the road and flipping the bike. This is a tried and true form of frame protection used in AMA, World Superbike, and MotoGP racing. Underbody Sliders are a viable no-cut alternative, and in most cases, are a lower cost option. Available for the Ducati 1098/1198/848, MV Agusta 312R/312RR, Kawasaki Ninja 650R, and more!

Underbody Slider for Kawasaki Ninja 650R



Frame Skidders

Frame Skidders are a new type of frame slider. R&G Frame Skidders combine excellent crash resistance with subtle styling compared to a traditional frame slider. You can inexpensively fix single-sided crash damage with the purchase of half kits.

Made from high-density polyethylene



Starting At
\$187⁰⁰
per pair

2011 Aprilia Tuono



Check page 24-27 to see which R&G products are available for your bike.



Axle & Swingarm Sliders

Front Axle sliders and swingarm sliders and spools protect your swingarm and axles from crash damage. Each slider is constructed of heavy-duty machined steel and aluminum with high-density nylon pucks for maximum protection. These sliders also give your bike a race look.

Front Axle Sliders

Starting At
\$57⁰⁰
per pair

Front axle sliders protect expensive axles, fork legs and calipers with a through-bolt design for secure and easy installation.



All necessary hardware included

Swingarm Sliders/Spools

Starting At
\$42⁰⁰
per pair

Swingarm spools protect the swingarm from damage *and* provide a secure support when lifting your bike using a race stand.



Constructed from tough high-density polyethylene

Offset Swingarm Sliders/Spools

Starting At
\$80⁰⁰
per pair

Offset swingarm spools are offset-mounted using an aluminum block, ideal for swingarms with or without threaded bosses. Protect your swingarm while providing a secure lifting point when using a race stand.

Black anodized aluminum bracket (included)



Front Axle Slider - Triumph Sprint GT



Swingarm Spool - Tiger 800

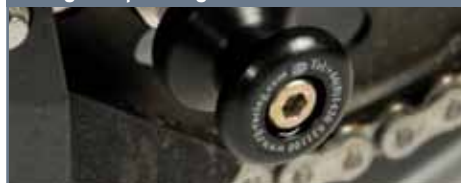

Offset Swingarm Spool - BMW S1000RR



Bar End Sliders

Bar end sliders are designed to protect your bar end and upper fairing and windscreen. R&G bar end sliders are made from steel and high-density nylon and are designed not to snap off on impact. R&G bar end sliders are a direct replacement of the original bar end weights on your bike.

Starting At
\$43⁰⁰
per pair

Constructed of tough steel and high-density polyethylene



Check page 24-27 to see which R&G products are available for your bike.



Radiator & Oil Cooler Guards

Radiator Guards

Your radiator is a vulnerable component that needs protection. The R&G radiator guard is made from pressed aluminum and features a neat, seamless frame. The attractive black finish looks terrific while helping to protect the expensive radiator from flying debris.



Starting At
\$70⁰⁰

Oil Cooler Guards

Wouldn't it stink to be miles from anywhere when you find out that something put a hole in your oil cooler? Avoid that nightmare with an R&G oil cooler guard. These black, pressed aluminum oil cooler guards will prevent punctures caused by flying rocks, sticks and other objects. Easy to install, protective, and good looking.



Starting At
\$68⁰⁰

Triumph Tiger 800 XC Radiator Guard



BMW R1200GS Oil Cooler Guard



Engine Case Covers

R&G Racing Engine Case Covers

are an easy, inexpensive, and innovative way to protect vulnerable and expensive crankcases and water pump cases from crash damage. The R&G engine case covers are vacuum-formed from durable 4mm polypropylene for great protection and good looks. These covers are motorcycle-specific and form-fit to simply bolt over the existing OEM covers.



Includes all necessary mounting hardware.

BMW S1000RR Engine Case Covers



Starting At
\$76⁰⁰
per cover

Tank Sliders

R&G Tank Sliders are made from Kevlar-reinforced carbon fiber, offering excellent crash protection and wear resistance. Tank sliders are specially molded to fit onto the area of the fuel tank that is most likely to take a hit in a crash or drop. Save your tank from scratches and dents that can lead to an expensive replacement. Installation is quick and easy with included self-adhesion panels.

Starting At
\$107⁰⁰
per pair

Yamaha R6 (06-) Tank Sliders



Check page 24-27 to see which R&G products are available for your bike.



Adjustable Rearsets

R&G Adjustable Rearsets allow you to tune your motorcycle's ergonomics for maximum comfort and control. R&G Adjustable Rearsets offer an exceptionally wide range of adjustability with 11 mounting positions. The shift and brake levers are height and angle adjustable and the location of the toe contact pieces can be modified to suit every rider. Specially textured footrests ensure maximum grip in all conditions. R&G Adjustable Rearsets are beautifully crafted from black powdercoated billet aluminum for a strong yet lightweight rearset with an exquisite custom look. Available for both street and race shift patterns (street pattern = 5 up, 1 down, and race pattern = 1 up, 5 down).



Starting At
\$429⁰⁰

per set

BMW S1000RR Adjustable Rearset, left side (street shift pattern)



BMW S1000RR Adjustable Rearset, right side



Exhaust Protectors

R&G Exhaust Protectors reduce the likelihood of scrapes to your exhaust can from a fall. Exhaust protectors feature a large shock absorbing thermal silicone rubber piece underneath protective slider. The clamp is incorporated into the design, making installation quick and easy.



Starting At
\$43⁰⁰

BMW S1000RR Akropovic exhaust with Exhaust Protector



Exhaust Hangers

Exhaust Hangers provide a custom-looking, lightweight alternative to your original exhaust hangers. Replaces the passenger peg mount for those sport bike riders who ride solo. A passenger footrest blanking plate (sold separately) is available for the non-exhaust side for a custom look (see next page for footrest blanking plates).

Starting At
\$76⁰⁰



Kawasaki ZX10R equipped with Exhaust Hanger (using passenger peg mount)



Check page 24-27 to see which R&G products are available for your bike.



Frame Plugs, Blanking Plates & Mirror Block-off Plates

Frame Plugs fill frame voids to keep dirt out and to conceal unsightly swingarm pivot or motor mount hardware for a clean, custom look. Mounting hardware is included.

Starting At
\$23⁰⁰



Frame plug installed

Frame Plug - BMW S1000RR



Footrest Blanking Plates are for solo riders who choose to remove the passenger footpeg brackets. These plates tidy up the rear of your bike after removing the rear footrest hangers. Mounting hardware is included.

Starting At
\$43⁰⁰



Passenger footpeg bracket removed

Blanking Plate - BMW S1000RR



Blanking plate installed

Mirror Block-off Plates

cover the exposed mirror mounting bracket after the mirrors are removed. These aluminum block-off plates are popular with track day riders who must remove their mirrors for safety and for custom sport bike builders who choose a custom mirror option. The block-off plates also keep the fairing from flapping when the original mirrors are removed. Mounting hardware is included.

Starting At
\$51⁰⁰



Mirror removed

Mirror Block Off Plate - BMW S1000RR



Block-off plate installed

Toe Chain Guards

Toe Chain Guards keep your feet or hands from being caught between the chain and rear sprocket in the event of a crash. R&G toe chain guards are made from either ABS, aluminum or lightweight, high-density polyethylene, depending on the application.

Starting At
\$43⁰⁰



Toe Chain Guard for Suzuki GSX-R600 and GSX-R750 ('11-)



Check page 24-27 to see which R&G products are available for your bike.



Rear Huggers & Fender Eliminators

Rear Huggers are designed to enhance the look of your bike and protect the shock and sub-frame under tray from dirt and debris that is kicked up by the rear tire.



Starting At
\$132⁰⁰

Fender Eliminators clean up the visual clutter of the typical original rear fender. The kit includes an integrated license plate holder and LED license plate illumination light.



Starting At
\$58⁰⁰

Honda VFR1200F Hugger



Honda CBR1000RR Fender Eliminator



Shock Protectors

R&G Shocktubes prevent damage to your rear shock caused by road salt, water spray, stone chipping, dust and dirt. The Shocktube is a high-impact, waterproof, vented Neoprene™ tube that is lined with stretch nylon on both sides.

The Shocktube can be fitted to most motorcycles with either monoshock or twin shock systems without the need to remove the shock absorber!

Starting At
\$42⁰⁰



Knee Sliders

R&G Aero knee sliders are offered in a medium compound and are ergonomically designed for maximum comfort, by means of a unique shaping against the knee. They are interchangeable for maximum use. As used and tested by many racers and the California Superbike School.

\$43⁰⁰



RG.AKS0001

Bike Covers

R&G Motorcycle Covers are the next best thing to a secure garage. R&G bike covers are waterproof and breathable with a soft liner inside the top of the cover to protect your bike's paint. Loopholes are located at both ends of the cover to accept a lock and chain and for tying down the cover in high winds. An elasticized bottom offers a snug fit. Universal sized cover to fit most types of motorcycles.

\$71⁰⁰



RG.BC0001BK

Check page 24-27 to see which R&G products are available for your bike.



SW-MOTECH Frame Sliders

offer rugged protection and a sporty, integrated design that looks great. SW-MOTECH sliders are constructed of CNC-milled PA6-MO aluminum alloy for high strength. Slider pads are made from high-performance plastic with UV-resistant slider pads that provide enhanced load bearing and sliding properties, as well as excellent abrasion and wear resistance for maximum protection.

- Replacement slider pads available.

In some cases fairing cut-outs are required. Templates and center punches are included to make installation precise and easy.



Starting At
\$129⁰⁰

BMW 1000RR
STP.07.590.10600.B

Yamaha FZ8



BMW F800R



Slider crashed, bodywork pristine.



Kawasaki ER-6n



Triumph Sprint GT



Honda CB1000R kit



Suzuki SFV650 kit



Replacement Slider Set (sold in pairs)



STP.00.590.10000.B
\$49.99

BMW	from	to	Part Number
F800R	09	11	STP.07.590.10500.B
F800ST	07	11	STP.07.590.10400.B
S1000RR	10	11	STP.07.590.10600.B
HONDA	from	to	Part Number
CBR600RR	07	09	STP.01.590.10500.B
CB1000R	08	11	STP.01.590.10000.B
CBF1000	06	09	STP.01.590.10101.B
CBF1000F	10	11	STP.01.590.10101.B
CBR1000RR	08	11	STP.01.590.10200.B
KAWASAKI	from	to	Part Number
Ninja 650R	09	11	STP.08.590.10100.B
ER-6N	09	11	STP.08.590.10200.B
Versys	07	09	STP.08.590.10000.B
Versys	10	11	STP.08.590.10600.B
Z1000	10	11	STP.08.590.10500.B
ZX10R	08	10	STP.08.590.10300.B
ZX10R	11		STP.08.590.10800.B
SUZUKI	from	to	Part Number
GSX-R600	08	09	STP.05.590.10500.B
GSX-R600 and GSX-R750	11		STP.05.590.10700.B
SFV650 Gladius	09	11	STP.05.590.10000.B
GSX-R1000	09	09	STP.05.590.10600.B
TRIUMPH	from	to	Part Number
Street Triple 675	08	11	STP.11.590.10100.B
Speed Triple 1050	08	10	STP.11.590.10000.B
YAMAHA	from	to	Part Number
FZ6	07	11	STP.06.590.10000.B
FZ6R	10	11	STP.06.590.10800.B
YZF-R6	08	11	STP.06.590.10200.B
FZ8	10	11	STP.06.590.11000.B
FZ1	06	11	STP.06.590.10000.B
YZF-R1	09	11	STP.06.590.10400.B
FJR1300	08	11	STP.06.590.10300.B

Item	Notes	Item No.
Replacement Slider Set	Nylon. Black. Replacement for SW-MOTECH Frame Slider Kits. In pairs.	STP.00.590.10000.B

Honda CBR1000RR



Honda CB1000R



Triumph Street Triple



Suzuki GSX-R1000



Frame sliders absorb the abuse, protecting the frame, engine, and fairing.

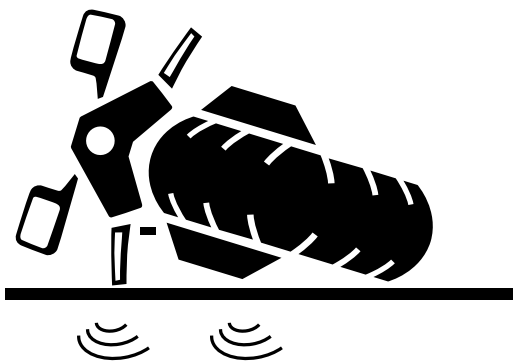

Unprotected motorcycle without Frame Slider Kit.



Protected motorcycle with SW-MOTECH Frame Slider Kit installed.



Starting At
\$69.99

per pair

SW-MOTECH Mirror Wideners

Are you tired of looking at your shoulders in your rearview mirrors? SW-MOTECH mirror wideners move your mirrors further out from your fairing and handlebars, providing a better view of traffic behind you.

SW-MOTECH uses several mirror widener shapes to provide solutions for the widest variety of motorcycles. Examples of the most common styles of mirror wideners are shown below. See the chart on the next page for your bike's application.

Most styles of mirror wideners are produced from CNC-milled billet aluminum. Profile Mirror Wideners are machined from a glass-fiber polyamide composite to provide a finish that matches original mirror mounts on most sport bikes. Mounting hardware is included.

HINGE Style Mirror Widener

HINGE mirror wideners are mounted between the socket and the mirror arm. Hinge-style wideners extend the length of the mirror arm by 40mm and provide an additional hinge point, allowing for a greater range of mirror positions.

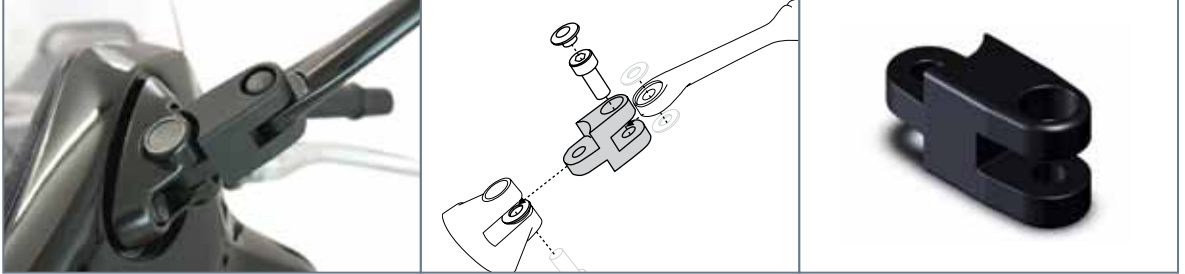

HINGE II Style Mirror Widener

HINGE II mirror wideners fit some Honda motorcycles, such as the NT650V Deauville. Hinge II wideners extend the length of the mirror arm by 40mm and provide an additional hinge point, allowing for a greater range of mirror positions.

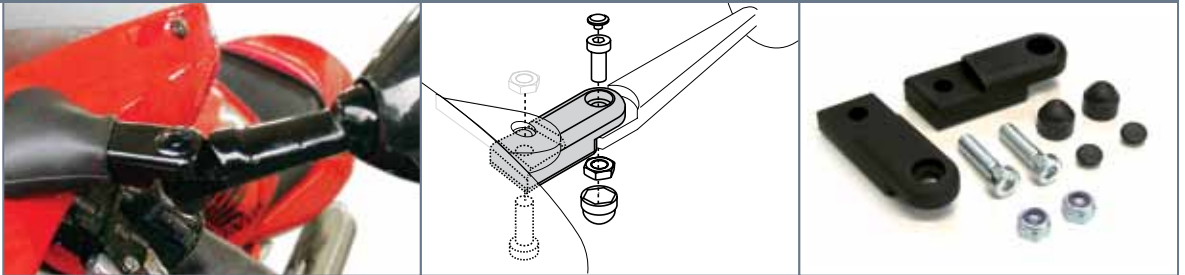

UNIVERSAL Style Mirror Widener

UNIVERSAL mirror wideners fit standard handlebars with M10 threaded mirror mount holes. These wideners extend the length of the mirror arm by 40mm and provide an additional hinge point, allowing for a greater range of mirror positions. The universal widener fits most enduro and naked sportbikes.

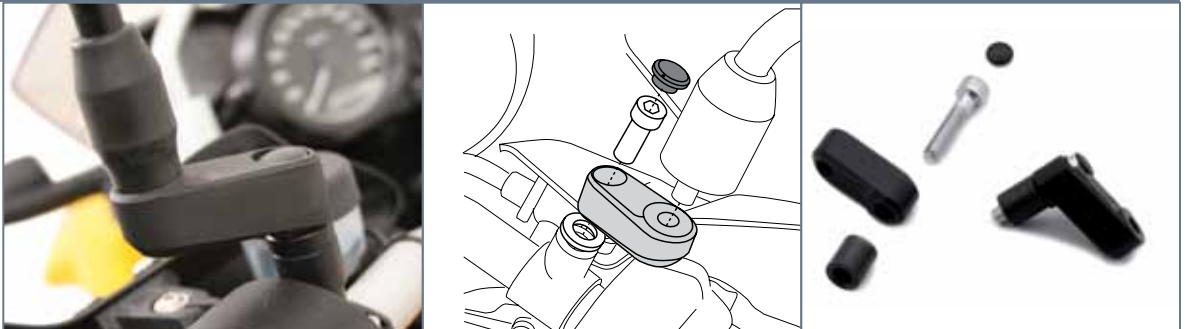

LINK Style Mirror Widener

LINK mirror extensions fit many newer Honda motorcycles with fairings, such as the CBR1000RR and extend the length of the mirror arm by 40mm. A greater range of motion is achieved by also adding a second pivot point.

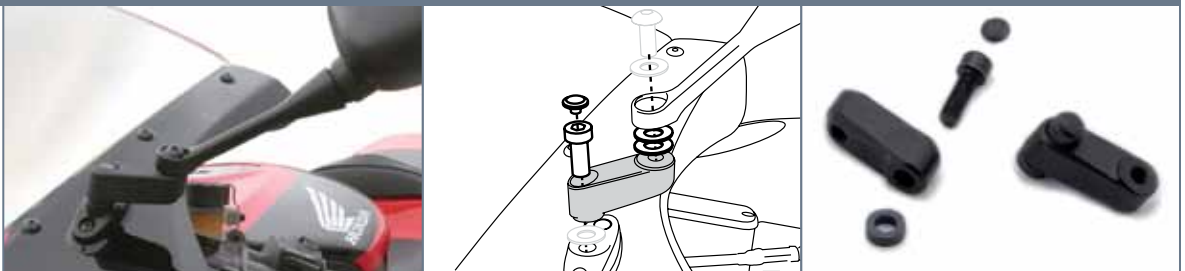

PROFILE Style Mirror Widener

PROFILE mirror wideners fit directly to the original profile of the mirror base. This type of mirror widener fits many sport bikes with fairings. Height varies by bike model.

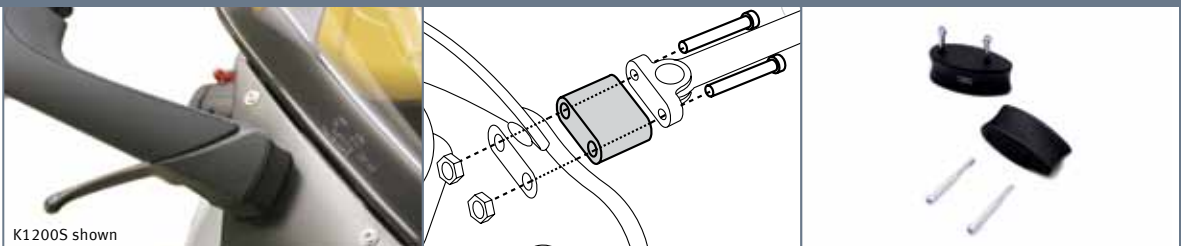

K1200S shown

Mirror Wideners				
	from	to	Style	Part Number
Aprilia				
Pegaso 650	'06	'12	Universal	SVL.00.505.101
RSV1000R	'06	'12	Profile	SVL.13.501.107
SL750 Shiver & NA850 Mana	'07	'12	Universal	SVL.00.505.101
Tuono 1000R Factory	'08	'10	Universal	SVL.00.505.101
BMW				
F650CS Scarver	'02	'09	Universal	SVL.00.505.102
F650GS & F650GS/Dakar	'00	'09	Universal	SVL.00.505.102
F650GS Twin	'08	'12	Universal	SVL.00.505.102
F800GS	'08	'12	Universal	SVL.00.505.102
F800S & F800ST	'06	'12	Profile	SVL.07.501.10800.B
F800R	'09	'12	Universal	SVL.00.505.102
G650GS	'11	'12	Universal	SVL.00.505.102
G650 Xchallenge/XCountry/Xmoto	'07	'09	Universal	SVL.00.505.102
K1200R, K1200R Sport & K1300R	'05	'12	Universal	SVL.00.505.102
K1200S & K1300S	'05	'12	Profile	SVL.07.501.105
R1150GS & R1100GS	'94	'05	Universal	SVL.00.505.101
R1200S	'05	'08	Profile	SVL.07.501.105
R1200GS & R1200GS Adventure	'04	'12	Universal	SVL.00.505.102
R1200R & R1200ST	'07	'10	Universal	SVL.00.505.102
S1000RR	'10	'12	Profile	SVL.07.501.10900.B
Ducati				
Multistrada 1200	'10	'12	Link	SVL.22.504.10000.B
Monster	'00	'12	Universal	SVL.00.505.101
Honda				
599	'04	'06	Universal	SVL.00.505.101
CB750	'93	'04	Universal	SVL.00.505.101
919	'02	'07	Universal	SVL.00.505.101
CB1000R	'08	'11	Universal	SVL.00.505.101
CBF1000	'06	'12	Link	SVL.00.503.100
CBR1000RR	'04	'07	Link	SVL.00.503.100
CBR1000RR	'08	'12	Profile	SVL.01.501.10600.B
CBR1100XX	'96	'07	Profile	SVL.01.501.104
CBR125	'04	'10	Universal	SVL.00.505.101
CBR600F4	'99	'08	Hinge	SVL.01.500.100
CBR600RR	'03	'07	Profile	SVL.00.503.100
CBR600RR	'08	'12	Profile	SVL.01.501.10700.B
NT650V Deauville	'98	'05	Hinge II	SVL.01.501.110
NT700V Deauville	'06	'12	Profile	SVL.01.501.11100.B
VFR750F	'90	'97	Profile	SVL.01.501.102
VFR800/ VFR800 VTEC	'02	'12	Hinge	SVL.01.500.100
VFR1200F	'10	'12	Profile	SVL.01.501.10600.B
XL1000V Varadero	'98	'12	Universal	SVL.00.505.101
Kawasaki				
Ninja 250R	'08	'12	Profile	SVL.08.501.103
Ninja 500R	'94	'12	Hinge	SVL.08.500.100
Ninja 500R	'87	'93	Profile	SVL.08.501.108
ZX6R Ninja	'95	'02	Profile	SVL.08.501.103
ZZR600	'03	'04	Profile	SVL.08.501.106
ZZR600	'05	'07	Profile	SVL.08.501.103
ZX6R & ZX6RR	'03	'04	Hinge	SVL.08.500.100
ZX6R & ZX6RR	'05	'07	Profile	SVL.05.500.100
ZX6R	'08	'12	Hinge	SVL.08.500.100
Versys 650	'06	'09	Universal	SVL.00.505.101
Ninja 650R	'06	'11	Hinge	SVL.08.500.100
ER6N	'06	'12	Universal	SVL.00.505.101
KLR650A/B/C	'86	'07	Universal	SVL.00.505.101
KLR650E, requires TT.SVL.05.101	'08	'12	Universal	SVL.00.505.101
Z750S	'05	'07	Hinge	SVL.08.500.100
ZR7S	'03	'04	Profile	SVL.08.501.104
Z1000	'04	'12	Universal	SVL.00.505.101
ZX10R	'08	'10	Hinge	SVL.05.500.100
ZX10R	'11	'12	Profile	SVL.08.501.11200.B

Mirror Wideners				
	from	to	Style	Part Number
Kawasaki (continued)				
ZZR1200	'02	'05	Profile	SVL.08.501.104
ZZR1400	'06	'12	Hinge	SVL.08.500.100
KTM				
KTM 690 Duke/950 Supermoto/LC8/990 Supermoto	'03	'12	Universal	SVL.00.505.101
Moto Guzzi				
Norge, Griso & Nevada Classic	'05	'12	Universal	SVL.00.505.101
Breva 1200, 1100, 750	'05	'12	Universal	SVL.00.505.101
Suzuki				
B-King	'07	'10	Universal	SVL.00.505.101
DL1000 V-Strom	'02	'06	Universal	SVL.00.505.101
DL650 V-Strom	'04	'11	Universal	SVL.00.505.101
DL650 V-Strom	'12	'12	Universal	SVL.00.505.10500
DRZ-400	'99	'02	Universal	SVL.00.505.101
DR650SE	'04	'12	Universal	SVL.00.505.101
GS500E	'88	'08	Universal	SVL.00.505.101
GS500F	'04	'12	Hinge	SVL.05.500.100
GSF1200S Bandit	'01	'05	Profile	SVL.05.501.103
GSF1250S Bandit	'07	'12	Hinge	SVL.05.500.100
GSF600S Bandit	'00	'04	Profile	SVL.05.501.103
GSF650S Bandit	'05	'12	Hinge	SVL.05.500.100
GSF 600/650/1200/N Bandit	'00	'04	Universal	SVL.00.505.101
GSX600F & GSF750F Katana	'98	'07	Profile	SVL.05.501.104
GSX650F	'08	'12	Hinge	SVL.05.500.100
GSX1300R Hayabusa	'99	'08	Profile	SVL.05.501.101
GSX1340R Hayabusa	'08	'12	Profile	SVL.05.501.101
GSX-R600	'04	'05	Hinge	SVL.05.500.100
GSX-R600	'06	'12	Profile	SVL.05.501.11000.B
GSX-R750	'96	'99	Profile	SVL.05.500.100
GSX-R750	'00	'03	Hinge	SVL.05.501.101
GSX-R750	'06	'08	Profile	SVL.05.501.106
GSX-R750	'08	'12	Profile	SVL.05.501.10800
GSX-R1000	'01	'02	Profile	SVL.05.501.101
GSX-R1000	'03	'04	Hinge	SVL.05.500.100
GSX-R1000	'06	'09	Profile	SVL.05.501.106
GSX-R1000	'09	'12	Profile	SVL.05.501.10800.B
SV650N & SV1000N	'98	'10	Universal	SVL.00.505.101
SV650S & SV1000S	'03	'10	Profile	SVL.05.500.100
SV650S	'98	'02	Profile	SVL.05.501.102
Triumph				
Speed Triple 1050	'04	'12	Universal	SVL.00.505.101
Street Triple 675	'08	'12	Universal	SVL.00.505.101
Daytona 675	'07	'12	Profile	SVL.11.501.10000.B
Thruxton & Scrambler	'04	'12	Universal	SVL.00.505.101
Tiger 800/800XC	'11	'12	Universal	SVL.00.505.101
Tiger 900/955/1050	'01	'12	Universal	SVL.00.505.101
Yamaha				
FJR1300	'01	'12	Profile	SVL.06.501.101
FZ6 S2 Fazer	'07	'12	Profile	SVL.06.501.101
FZ8	'11	'12	Universal	SVL.00.504.101
FZ1	'01	'12	Profile	SVL.06.501.104
FZ1 Fazer	'06	'07	Profile	SVL.06.501.104
Majesty 400	-	'10	Universal	SVL.00.504.101
TDM900	'02	'12	Universal	SVL.00.504.101
WR250X, WR250R, XT250	'08	'12	Universal	SVL.00.504.101
XJ6	'09	'12	Profile	SVL.06.501.10700.B
XT1200Z Super Tenere	'10	'12	Universal	SVL.00.504.101
YZF-R1	'02	'08	Profile	SVL.06.501.102
YZF-R1	'09	'12	Profile	SVL.06.501.10500.B
YZF-R6	'99	'02	Profile	SVL.06.501.103
YZF-R6	'03	'05	Profile	SVL.06.501.102
YZF-R6	'08	'12	Profile	SVL.06.501.10600.B

For a complete listing of Mirror Wideners visit TwistedThrottle.com!



Adjustable Vario Footpegs

MFW's adjustable footpegs enhance comfort and add a touch of class to any motorcycle. This footpeg system provides 8 possible positions over a 360 degree range. Adjustability is accomplished through the use of a displacement arm attached to the bike-specific footpeg mount. Both footpeg mount and displacement arms have an indexed attachment surface for a secure installation. Once installed, it only takes a few minutes to switch between ultimate comfort for long treks and ultimate performance for strafing the twisties.

MFW footpeg kits are CNC-machined from billet aluminum and fit a wide range of motorcycles. All components are sold in pairs.

Starting At
\$161⁵⁰

per rider or passenger set

STEP 2

Choose your extension arm length

Extension arms lock into position every 45-degrees of rotation for a total of 8 possible footpeg positions.

STEP 1

Choose your bike-specific footpeg mount

The footpeg mount has 8 indexed rotational positions that the extension arm can lock into.

Find the proper rider or passenger footpeg mount for your bike on the next page.

50mm Extension Arm
(Passenger peg use only)
MFW.051.00.00.50

30mm Extension Arm
MFW.051.00.00.30

23mm Extension Arm
MFW.051.00.00.23

STEP 3

Choose your replacement peg

Footpegs come in three styles to suit your riding needs.

Scan here to watch the installation video.

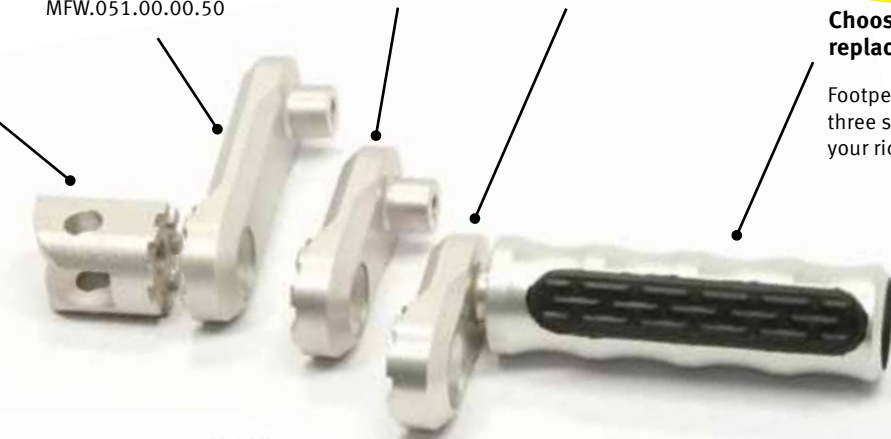

Racing Pegs
MFW.050.00.01.00-1 silver
MFW.050.00.01.00-8 black

Super Grip Pegs
MFW.050.00.04.00-1 silver
MFW.050.00.04.00-8 black

Master Grip Pegs
MFW.050.00.03.00-1 silver
MFW.050.00.03.00-8 black

Ultimate adjustability: choose from any combination of 8 rotational positions and 3 displacement lengths to accommodate any rider



Rear position

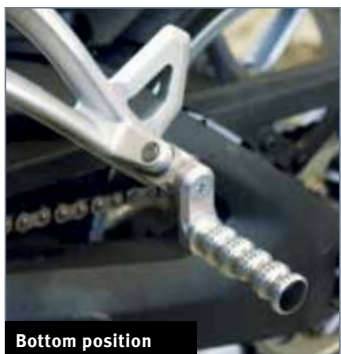

Bottom position



45° bottom forward



45° top forward

4 of the 8 possible rotational positions are shown using Master Grip pegs and a 30mm extension arm

	Part Number		Part Number	
Aprilia	from	to	Rider	Passenger
Pegaso 650 Factory & Trail	'05	'12	051.01.01.00	N/A
SL750 Shiver	'07	'12	051.01.01.00	051.01.01.10
Mana 850	'07	'12	051.01.01.00	051.01.01.10
RSV1000, RSV1000R, RSV1000SP	'97	'12	051.01.01.00	051.01.01.10
SL1000 Falco	'00	'12	051.01.01.00	051.01.01.10
Tuono 1000R & 1000R Factory	'05	'12	051.01.01.00	051.01.02.10
BMW	from	to	Rider	Passenger
F650GS & F800GS	'08	'12	051.02.04.00	051.02.04.10
F800S & F800ST	'06	'12	051.02.03.00	051.02.03.10
R1200RT, R1150RT, R1100RT, R1100RS, R1100R	'96	'12	051.02.01.00	051.02.01.10
R1150GS, & R1100GS	'05	'12	051.02.04.00	051.02.01.10
R1150R, R1150RS, & R1100S	'98	'12	051.02.02.00	051.02.02.10
K1200S, K1200R, K1200R Sport, K1300R	'04	'12	051.02.03.00	051.02.03.10
R1200R, R1200S, & R1200ST	'05	'12	051.02.03.00	051.02.03.10
R1200GS	'04	'09	051.02.04.00	051.02.01.10
R1200GS Adventure	'04	'12	051.02.05.00	051.02.01.10
S1000RR	'10	'12	051.02.06.00	051.02.05.10
Ducati	from	to	Rider	Passenger
695 Monster	'06	'12	051.03.01.30	051.03.05.10
696 Monster	'08	'12	051.03.01.00*	051.03.05.10
796 Hypermotard	'07	'12	051.03.04.00	051.03.01.10
1000S Monster, 748, 750SSie, 900SSie, 996, 998	'94	'10	051.03.03.00*	051.03.01.30
848	'07	'12	051.03.03.00	N/A
Monster S2R, S4R, & S4RS	'03	'10	051.03.01.30	051.03.01.30
GT1000 & Sport 1000S	'03	'12	051.03.01.30	051.03.01.30
1098S	'07	'12	051.03.03.00*	051.03.01.30
Hypermotard 1100	'07	'19	051.03.04.00*	051.03.05.10
Multistrada 1100DS	'05	'12	051.03.04.00	051.03.01.30
1198	'09	'12	051.03.03.00	051.03.01.30
Streetfighter	'09	'12	051.03.03.30*	051.03.03.30*
Hypermotard Evo/SP	'07	'12	051.03.04.00	051.03.05.10
Multistrada 1200/S	'10	'12	051.03.04.00	051.03.01.30
Diavel 1200 ABS/Carbon	'11	'12	051.03.05.00	N/A
Honda	from	to	Rider	Passenger
599 / CB600F Hornet	'98	'09	051.04.01.00	051.04.02.10
CBR600F	'95	'08	051.04.01.00	051.04.01.10
CBR600RR	'03	'12	051.04.01.00	051.04.01.10
NT700V Deauville	'10	'12	051.04.01.00	051.04.04.10
VFR800	'98	'12	051.04.01.00	051.04.01.10
CBF1000	'07	'12	051.04.01.00	051.04.04.10
CBR1000RR	'04	'12	051.04.01.00	051.04.01.10
VTR1000 SP1 / SP2	'00	'12	051.04.01.00	051.04.01.10
XL1000V Varadero	'99	'12	051.04.01.00	051.04.01.10
CBR1100XX Blackbird	'97	'12	051.04.01.00	051.04.01.10
VFR1200F	'10	'12	051.04.01.00	051.04.01.10
CB1300	'03	'11	051.04.01.00	051.04.01.10
ST1300 Pan European	'03	'12	051.04.01.00	051.04.01.10
Kawasaki	from	to	Rider	Passenger
Ninja 500R / GPZ500S / EX500	'87	'12	051.05.02.00	051.05.02.10
Ninja 650R	'05	'12	051.05.03.00	051.05.03.10
ER-6N	'05	'12	051.05.03.00	051.05.03.10
Z 750 R	'10	'12	051.05.03.00	051.05.03.10
ZX6R (ZX600J)	'00	'02	051.05.01.00	051.05.03.10
ZX6RR & ZX6R 636 Ninja (ZX636B)	'03	'04	051.05.01.00	051.05.03.10
ZX6RR & ZX6R (ZX636C/D, ZX600P)	'05	'12	051.05.03.00	051.05.03.10
Versys 650	'06	'12	051.05.01.00	051.05.03.10

*Footpeg adapter available in black.

	Part Number		Part Number	
Kawasaki (continued)	from	to	Rider	Passenger
KLR650A & KLR650E	'87	'12	051.05.02.00	051.05.02.10
Z1000 & Z1000SX	'03	'12	051.05.01.00	051.05.03.10
ZX10	'08	'09	051.05.01.00	051.05.01.10
ZX10R	'04	'12	051.05.03.00	051.05.03.10
ZRX1200R	'02	'12	051.05.01.00	051.05.03.10
ZX12R	'00	'12	051.05.01.00	051.05.03.10
ZZR1200	'02	'12	051.05.01.00	051.05.03.10
Concours GTR1400	'08	'12	051.05.03.00	051.05.03.10
ZX14 / ZZR1400	'06	'12	051.05.01.00	051.05.03.10
Moto Guzzi	from	to	Rider	Passenger
V11	'98	'06	051.55.01.00	051.55.01.10
Griso 1200	'05	'12	051.55.03.00	051.55.03.10
MV Agusta	from	to	Rider	Passenger
F4	'04	'09	051.03.03.00	N/A
Suzuki	from	to	Rider	Passenger
GSF600N & GSF600S Bandit	'96	'04	051.06.02.30	051.06.04.10
GSX-R600	'97	'07	051.06.01.30	051.06.04.10
GSX-R600	'08	'12	051.06.11.30	051.06.07.10
DL650 V-Strom	'04	'12	051.06.11.30	051.06.05.30
GSF650N & GSF650S Bandit Non-ABS	'05	'12	051.06.11.30	051.06.04.10
GSF650S Bandit ABS	'07	'12	051.06.11.30	051.06.07.10
GSX650F	'08	'12	051.06.11.30	051.06.07.10
SV650N & SV650S	'99	'12	051.06.01.30	051.06.04.10
Gladius SFV650	'08	'12	051.06.11.30	051.06.07.10
GSR 750	'10	'12	051.06.01.30	051.06.07.10
GSX R750	'96	'07	051.06.01.30	051.06.04.10
GSX R750	'08	'12	051.06.11.30	051.06.07.10
DL1000 V-Strom	'02	'12	051.06.11.30	051.06.66.10
GSX-R1000	'00	'04	051.06.01.30	051.06.04.10
GSX-R1000	'05	'12	051.06.11.30	051.06.07.10
SV1000N & SV1000S	'03	'12	051.06.01.30	051.06.04.10
GSF1200S Bandit	'96	'05	051.06.02.30	051.06.02.30
GSF1250S, GSX1250FA Bandit	'07	'12	051.06.11.30	051.06.07.10
GSX1300R Hayabusa	'99	'07	051.06.11.30	051.06.04.10
GSX1340R Hayabusa	'08	'12	051.06.11.30	051.06.07.10
B-King	'07	'12	051.06.11.30	051.06.07.10
Triumph	from	to	Rider	Passenger
Daytona 675	'06	'12	051.07.03.00	051.07.06.10
Street Triple 675	'08	'12	051.07.03.00	051.07.07.10
Thruxton 900	'04	'12	051.07.03.00	051.07.02.10
Speed Triple 955 & 900	'99	'12	051.07.03.00	051.07.03.10
Tiger 955i & 900	'99	'12	051.07.02.00	051.07.02.10
Daytona 955i	'01	'12	051.07.03.00	051.07.03.10
Sprint 955 ST & RS	'01	'12	051.07.02.00	051.07.03.10
Speed Four	'04	'12	051.07.06.00	051.07.03.10
Speed Triple 1050	'05	'12	051.07.03.00	051.07.04.10
Sprint ST 1050	'05	'12	051.07.05.00	051.07.05.10
Tiger 1050	'06	'10	051.07.03.00	051.07.04.10
Yamaha	from	to	Rider	Passenger
FZ6	'04	'12	051.08.01.00	051.08.01.10
FZ8	'10	'12	051.08.01.00	051.08.01.10
YZF R6 & R6S	'03	'12	051.08.04.00	051.08.04.10
FZ1	'01	'05	051.08.01.00	051.08.33.10
FZ1	'06	'12	051.08.01.00	051.08.01.10
YZF R1	'00	'06	051.08.04.00	051.08.04.10
YZF R1	'07	'12	051.08.04.00	051.08.05.10
FJR1300	'06	'12	051.08.01.00	051.08.33.10
Super Tenere XT 1200Z	-10	'12	N/A	051.08.01.10



BMW R1200GS



SW-MOTECH Convertible Footpegs

provide an extra-wide platform for enhanced comfort and grip, for both on and off-road riding! A single bolt allows you to remove the rubber pad for off-road riding and reinstall it for on-road riding. A second bolt allows you to raise or lower the footpeg by 15mm.

- Attaches to the original footpeg mount.
- Footpeg mounting kit is CNC-milled from high strength aluminum alloy.
- Convertible design is great for both street and off-road riding.
- Removable rubber pads reduce vibration for street riding.
- Toothed surface provides superior traction for off-road riding.
- 3.5" long x 2.25" wide, larger than most original footpegs for enhanced comfort and grip.
- Footpegs are made from high-grade, corrosion-resistant stainless steel.

Starting At
\$158⁹⁹

Attaches to original footpeg mount



Removable rubber pad reduces vibration during street riding



Large teeth provide maximum grip in slippery off road conditions



Wider is Better!



Rubber pad is removable with one bolt



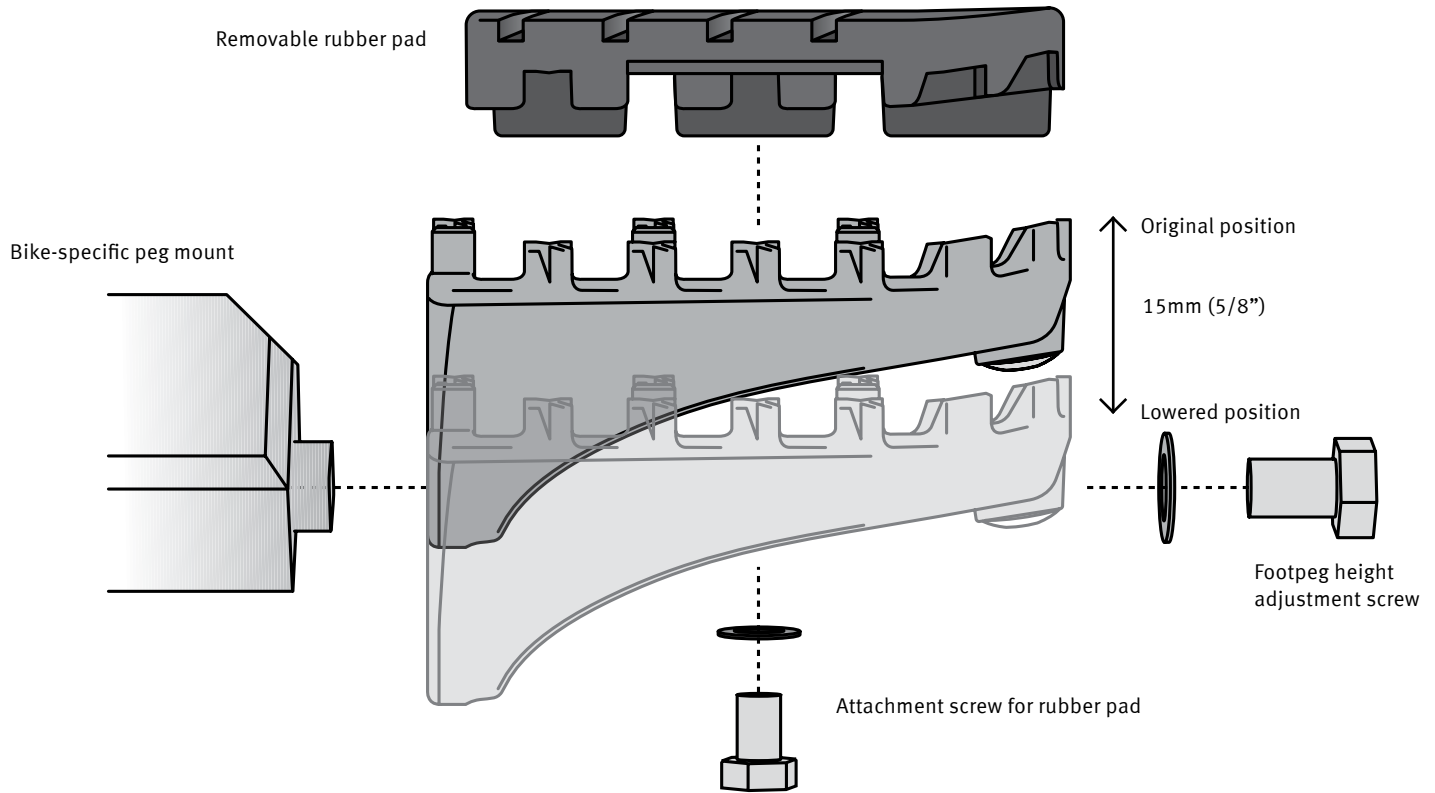

Two footpeg mounting positions: Original or lowered by 15mm!

Aprilia	Part Number
750 Shiver GT, '08 and later	FRS.05.011.10000.S
SMV750 Dorsoduro, '08 and later	FRS.13.011.10100.S
BMW	Part Number
F650CS Scarver, '03 - '06	FRS.01.011.10400.S
F800R, '08 - '10	FRS.05.011.10000.S
G650GS, '08 - '10	FRS.07.011.10000.S
F650GS single, '00-'07/twin, '08-'10	FRS.07.011.10000.S
F800GS, '08 - '11	FRS.07.011.10100.S
R1200GS, '04 - '11	FRS.07.011.10500.S
R1100GS, '94 - '99	FRS.07.011.10500.S
R1150GS Adventure, '02 - '05	FRS.07.011.10500.S
R1150GS, '99 - '04	FRS.07.011.10500.S
Ducati	Part Number
Multistrada 1200, '10 and later	FRS.22.011.10000.S
Honda	Part Number
XL650V Transalp, '00 - '08	FRS.01.011.10200.S
XL1000V Varadero, '07 - '12	FRS.01.011.10400.S
CB1300 / S, '03 - '10	FRS.01.011.10400.S
Kawasaki	Part Number
Versys 650, '07 - '11	FRS.08.011.10000.S
Z1000, '07 - '09	FRS.08.011.10000.S
ZRX1200R, '01 - '06	FRS.08.011.10000.S
KLR650E, '08 - '11	FRS.08.011.10200.S



KTM	Part Number
690 Duke, '07 - '10	FRS.04.011.10100.S
LC8 Adventure 950, '03 - '05	FRS.04.011.10100.S
LC8 Adventure 990, '08 and later	FRS.04.011.10100.S
950 Supermoto, '06 - '08	FRS.04.011.10100.S
950 Supermoto R, '07 - '08	FRS.04.011.10100.S
990 SM, SMR, & SMT, '08 and later	FRS.04.011.10100.S
Moto Guzzi	Part Number
Stelvio 1200, '08 - '09	FRS.17.011.10000.S
MotoMorini	Part Number
Granpasso 1200, '08 and later	FRS.17.011.10000.S
Suzuki	Part Number
DL650 V-Strom, '04 - '12	FRS.05.011.10000.S
GSX650F, '10 and later	FRS.05.011.10100.S
DL1000 V-Strom, '02 and later	FRS.17.011.10000.S
GSF1250 Bandit S, '07 - '12	FRS.05.011.10100.S
GSX1250F ABS, '09 - '12	FRS.05.011.10100.S
Triumph	Part Number
Speed Triple 1050, '04 - '07	FRS.01.011.10400.S
Tiger 800, '11 - '12	FRS.11.011.10100.S
Tiger 1050, '06 and later	FRS.11.011.10000.S
Yamaha	Part Number
XT 1200 Z Super Tenere, '11-'12	FRS.06.011.10000.S

Footpeg kits for more bikes are in development. Check out TwistedThrottle.com for the latest models!

MRA Adjustable Windshields



Decades of aerodynamic screen development have gone into the design of the **X-creen** by MRA. Building on the success of the MRA VarioTouring screen design, the X-creen is MRA's most versatile screen to date with superior windscreen adjustability and performance. Adjustment requires no tools and the range of height and angle is infinite. No replacement windshield offers more air flow adjustability.
Available in clear or smoke gray.

NEW
Starting At
\$209⁹⁹

X-creens are currently available for the following bikes:

BMW
F800GS and F650GS twin ('08 & Later)
G650GS ('11 & Later)
K1200S ('04 & Later)
K1300S ('09 & Later)
R1200GS ('06 & Later)
R1200GS Adventure ('06 & Later)
R1200S ('06 & Later)
Can-Am
Spyder RS ('07 & Later)
Ducati
Multistrada 1200 / S ('09 & Later)
Honda
CBF1000 ('06 & Later)
CBF1000F ('10 & Later)
Crossrunner ('11 & Later)

Honda (continued)
NTV700 Deauville ('06 & Later)
XL1000 V Varadero ('03 & Later)
Kawasaki
ER6F ('09 & Later)
GTR1400 Concours ('07 & Later)
KLR650 ('08 & Later)
Versys 650 ('06 & Later)
Suzuki
DL1000 V-Strom ('04 & Later)
DL650 V-Strom ('04 - '12)
GSF1200S ('01-'05)
GSF1200S Bandit ('01 & Later)
GSF1250 Bandit ('06 & Later)
GSF1250SA Bandit ('07 & Later)
GSF650 Bandit ('05 & Later)

Suzuki (continued)
GSF650S ('09 & Later)
GSF650S Bandit ('05 - '08)
GSR600 ('06 & Later)
GSX650F ('08 & Later)
GSX1250FA ('10 & Later)
Kawasaki
Sprint ST 1050 ('05 & Later)
Tiger 1050 ('06 & Later)
Tiger 800 & 800XC ('10 & Later)
Yamaha
FZ600 S2 Fazer ('07 & Later)
FZ1 Fazer ('06 & Later)
FZS1000 FZ1 ('01 - '05) Fazer ('06 & Later)
T-Max 500 ('08 & Later)
XT1200Z Super Tenere ('10 & Later)

More models in development! Visit TwistedThrottle.com for the latest X-creen application list.

The X-creen spoiler is 14.1" wide x 5" tall and has 4.3 inches of vertical travel.



The spoiler's angle and height can be adjusted independently.

The Twisted BMW R1200GS

BMW G650GS (2012)



Triumph Tiger 800 (2011)



Suzuki DL650 V-Strom (2012)



MRA X-creen Adjustable Windshield Spoilers

MRA X-creen Spoilers attach directly to your bike's existing windshield. The included mounting kit fits almost any windshield, regardless of its curvature. The included extension arm adds the ability to raise and lower the spoiler's height by 2.15 inches (for a total of 4.3 inches of travel). You have the option of using the X-creen spoiler's single pivot mounting hinge, which allows you to pivot the angle of the X-creen, but not the height.

Choose from either **Bolt-on** or **Clamp-on** mounting options. Each kit includes a single and double pivot arms.

Bolt-On: The spoiler bolts directly to your original windshield. Installation requires drilling four 6mm-diameter holes in your windshield, but offers the cleanest looking installation. Includes spoiler, hinge system, and drill-on mounting hardware.

MRA.XCA.0 - Clear
MRA.XCA.1 - Smoke Gray

\$129⁹⁹

Clamp-On: The spoiler clamps onto your original windshield. Installation is easier, requiring no drilling, but the hardware is larger and more noticeable. Includes the spoiler, hinge system, and clamp-on mounting hardware.

MRA.XCC.0 - Clear
MRA.XCC.1 - Smoke Gray

\$149⁹⁹



Honda VFR1200F with X-creen Spoiler clamped to the original screen

The mounting hinge allows you to pivot the angle of the X-creen

Clamp-On part# MRA.XCC.0



Bolt-On part# MRA.XCA.1



Use the included extension arm to add 4.3 inches of height adjustment

Clamp-On part# MRA.XCC.1



Bolt-On part# MRA.XCA.1



VT - VarioTouringScreen

Starting At
\$155⁰⁰

The VarioTouringScreen is similar to the X-creen, but has a slightly smaller factory-installed adjustable spoiler at the top of the windscreen. The VarioTouring spoiler is approximately 3.5" tall and has a smaller range of adjustability than the X-creen. The rider can manually adjust the angle and height of the spoiler to redirect airflow to suit the current conditions. The spoiler's design reduces turbulence and buffeting for increased rider stamina. Provides wind-flow adjustability in a clean, compact design!

Available in clear or smoke gray.

MRA's VarioTouring Windscreens are adjustable to seven different positions to disperse the wind which helps diffuse air pressure and turbulence. The net effect is a reduction in rider fatigue



For a complete MRA application list, see page 42 or visit TwistedThrottle.com

BMW F800GS
MRA.07.017.VTM

R - Double Bubble RacingScreen

Starting At
\$95⁰⁰

Double Bubble RacingScreens

MRA has a long history of race screen development. The RacingScreen's raised center bubble takes wind pressure off the helmet and provides exceptional stability at racetrack speeds. Air vents have been added at the front edge of the screen to reduce the vacuum underneath the bubble and smooth out air flow.



Designed to generate ride stability at speed. Double bubble windshields decrease lift, applying a downward force to the front end of the motorcycle while reducing helmet buffeting.



The Twisted BMW S1000RR Project Bike

For a complete MRA application list, see page 42 or visit TwistedThrottle.com

T - TouringScreen

Starting At
\$110⁰⁰



2011 Yamaha Super Tenere

TouringScreens are similar in shape to your bike's original windscreen and are taller across the entire width of the windscreen, deflecting the wind over the rider and facilitating a relaxed drive, particularly on longer trips.

Extra-large "Arizona" TouringScreens are also available for some models.



Designed to enhance rideability. Think of the TouringScreen as an extension of the original screen. MRA evaluates and designs each screen for every application based on the unique ride characteristics and profile of the machine. The goal of the TouringScreen is to deflect wind pressure away from the rider, ensuring an easy and relaxing ride on longer trips.

For an application list, see page 42 or visit TwistedThrottle.com

RNB - RacingScreen for Naked Bikes

\$99⁹⁹

Mount kit sold separately

RacingScreens add style and function to any naked bike. With its racy design, the RacingScreen accentuates the visual appearance of your bike while offering excellent wind protection as you ride.

Available in smoke grey, black or clear. Requires MRA.HK or MRA.HKM28 mounting kits, sold separately **\$45.00 each**.



Honda CB1000R

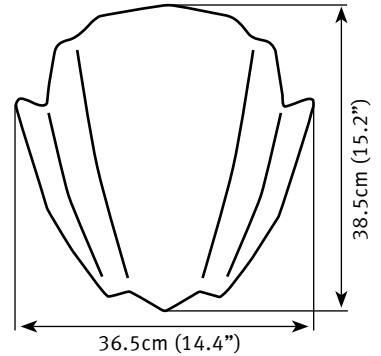

See page 43 for a list of over 100 bikes that the RacingScreen fits!

VNB - VarioScreen for Naked Bikes

\$169⁹⁹

Mount kit sold separately

The VarioScreen for Naked Bikes is a two-part windshield. The upper shield is adjustable in height by 2 inches (5 cm). There is an inlet at the lower end of the upper shield that allows air to circulate and minimize turbulence. This shield offers the most adjustability and wind protection available in any MRA handlebar-mounted screen.

Available in smoke grey or clear. Requires MRA.HK or MRA.HKM28 mounting kits, sold separately **\$45.00 each**.

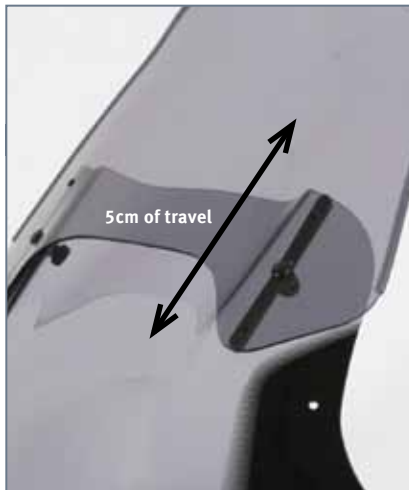

No tools are required to make height adjustments. Just twist the thumbscrews to loosen the sliders, adjust and re-tighten. The VarioScreen is designed to provide an air inlet at the base of the front section to allow a controlled flow of air behind the screen. This helps to reduce the air pressure and buffeting without creating additional drag and turbulence.

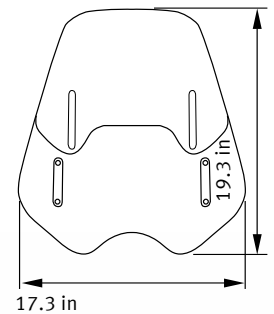

BMW R1200R

For a complete MRA application list, see page 43 or visit TwistedThrottle.com

MRA Screens for Naked Bikes

HI - HighwayShield

\$94.99

The striking design of this shield fits sporty naked bikes and roadsters. The size of the shield protects the entire upper part of the body up to the helmet from wind and weather. This shield is available in clear and smoke-gray.

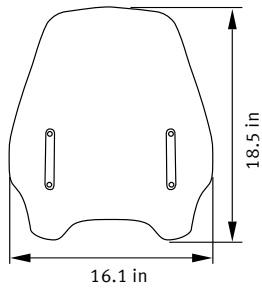

CU - CustomShield

\$94.99

Similar in shape to the HighwayShield, the CustomShield's contours are considerably rounder and more suited to the appearance of cruisers and choppers. Available in clear and smoke-gray.

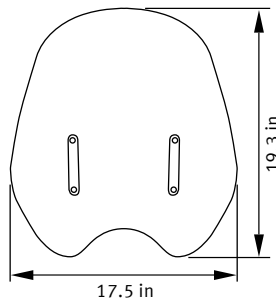

VTNB - VarioTouringScreen

\$149.99

The VarioTouringScreen is a "small shield with a big effect". This compact shield's extra spoiler reduces airflow velocity approaching the helmet and upper body without generating turbulence. With 7 manually adjustable positions, it's easy to find an optimal position to suit your riding style. Available in clear and smoke-gray.

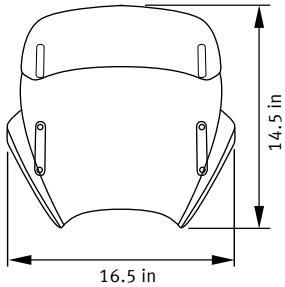

RO - RoadShield

\$94.99

The RoadShield is a small shield optimally suited for enduros and sporty naked bikes. The shield is deliberately made fairly wide for its height in order to avoid side turbulence. Available in clear and smoke-gray.

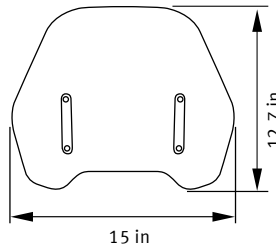

Handlebar Mounting Kits

\$45.00



MRA's HK handlebar mounting kit (**Part No. MRA.HK**) fits bikes with 7/8" or 1" diameter handlebars. For 28mm handlebars, use MRA's HKM28 (**Part No. MRA.HKM28**). For use with MRA naked bike windscreens (sold separately).

For a complete MRA application list, see page 42-43 or visit TwistedThrottle.com

MRA Windshield Color Options for Faired and Naked Bikes



Clear



Smoke Gray



Gloss Black (opaque)

Replacement Windshields for Faired Motorcycles and Scooters

Givi replacement windshields are generally offered in a single shape and color for each motorcycle model and year. Givi replacement windshields are designed to provide an improved aerodynamic profile, wind protection, and aesthetics.

Starting At
\$99⁹⁹

For a complete application list, visit TwistedThrottle.com

D257ST - Suzuki Burgman AN650, '02-'12
31"h x 29"w



D410ST - Kawasaki Versys, '10 & Later
18.9"h x 14.6"w

Not shown: D405ST Versys '07-'09



D331ST - BMW G650GS (-10) & F650GS ('04-'07)
15.5"h x 17.3"w



D260ST - Suzuki V-Strom DL650/DL1000
22.5"h x 19"w

DL650, '04-'11
DL1000, '04-'12



D214ST - Honda Silverwing 600
26.5"h x 23.5"w



D442B - Yamaha T-Max
23.2"h x 17.7"w



Universal Airstars Windshields and Fairings

Universal Airstars Windshields and Fairings for Naked Bikes & Cruisers

Givi's traditionally-styled windshields are great for metric cruisers, retro racers, and other bikes with a clean, classic look. Depending on the model, universal mounting hardware is included to attach the screen to the headlight, handlebars, or forks.

Starting At
\$81⁰⁰

A200 - Headlight Mounted
11.6"h x 13.4"w



A210 - Headlight Mounted
14.4"h x 13.8"w



A240 - Headlight Mounted
13"h x 14.4"w



A750 - Airstars Fairing
16"h x 15"w

Fits Monster, R1150R, SV650 & more!



A770 - Airstars Fairing
15.2"h x 17"w

Fits '03- SV650, SV1000, & more!

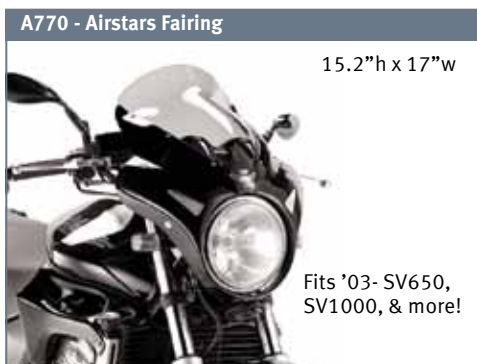

A755 - Airstars Fairing
14"h x 18"w



Airstars Fairings are available in matte black, gloss black & gloss silver.

The A755 can be used on the Honda 919 with the A256A fitting kit.

For a complete application list, visit TwistedThrottle.com

Styles and Colors Available:

- R** = Double-Bubble RacingScreen
- T** = TouringScreen*
- V** = VarioScreen*
- VT** = VarioTouringScreen*
- A** = Arizona TouringScreen*
- XC** = X-Creen
- X[†]** = only in smoke grey
- * = available in clear and smoke gray only

Colors Available: Clear
Smoke Gray
Gloss Black (opaque)

Aprilia	R	T	V	VT	XC
Pegaso i.e. ('02-'04)		X			
RS50 ('99-) & RS125 ('99-'05)	X				
RSV1000R Mille ('01-'03)	X	X			
RSV1000R Mille ('04-'09)	X				
RSV1000R Tuono ('05 & Earlier)	X				
BMW	R	T	V	VT	XC
F650 Funduro/F650ST ('97 & Later)	X				
F650GS & F800GS ('08-'12)				X	X
F800S & F800ST ('06-'12)		X		X	
G650GS ('11-'12)					
K100 RT/LT		A			
K1200R ('06-'08)				X	
K1300R ('09-'12)				X	
K1200S ('06-'08)	X	X	X	X	X
K1300S ('09-'12)	X	X	X	X	X
R60S / R100S Cockpit	X				
R850GS / R1100GS			X		
R1100RS	X	X			
R1100S	X	X	X		
R1150GS & R1150GS Adventure		X			
R1150RS		X			
R1200GS & R1200GS Adventure ('04-'12)		X	X	X	
R1200S ('06 & Later)	X	X		X	X
S1000RR ('09-'12)	X				
Can-Am	R	T	V	VT	XC
Spyder Roadster		X	X	X	
Ducati	R	T	V	VT	XC
696	X				
748 (R) / 916 / 996 / 998	X	X			
749 / 999 ('04 & Earlier)	X				
749 / 999 ('05 & Later)	X				
750 / 900SS-83 (half screen)					
750 / 900SS IE ('98 & Later)					
SS1000DS ('03 & Later)	X	X			
900SS ('95-'97)	X	X			
Multistrada 1100, 1000 & 620				X	
Multistrada 1200/S		X		X	X
1098 & 1098S		X			
1198 & 1198S		X			
Mike Hailwood Replica I					
Mike Hailwood Replica II					
Monster S2, S4 ('00 & Later), S2R ('06 & Later)		X			
ST2 / ST4		X			
Honda	R	T	V	VT	XC
CBF1000 ('06-'09)		X		X	X
CBF1000 F ('10-'12)		X		X	X
CBR600F/S ('01 & Later)	X	X			
CBR600RR ('03-'04)		X			
CBR600RR ('05-'06)		X			
CBR600RR ('07-'10)		X			

Honda (continued)	R	T	V	VT	XC
CBR900RR Fireblade ('00-'01)	X	X			
CBR929					
CBR900RR Fireblade ('02-'03) & CBR954	X	X		X	
CBR1000F ('93-'03)		X		X	
CBR1000RR ('04-'07)	X				
CBR1000RR ('08-'12)	X				
CBR1100XX Blackbird	X	X		X	
CBX750F		X			
Crossrunner	X	X	X	X	
GL1200 Goldwing		A			
GL1500 Goldwing		A			
GL1800 Goldwing		A			
GL500 / 650 / 1100 Goldwing		A			
NX650 Dominator ('91 & Earlier)	X				
NTV700 Deauville ('06-'12)				X	X
Silverwing				X	
ST1100 Pan European			X		
VF500 F 2		X			
VF750 F		X			
VF1000 F2		X			
VF1000 R		X			
VFR750 F-89					
VFR800 ('98-'01)	X	X		X	
VFR800 ('02-'12)	X			X	
VFR1200F	X	X			
VTR1000F Superhawk ('97-'05)	X	X			
VTR1000SP1 Firestorm / SP2	X	X			
XL1000V Varadero ('10-'12)				X	X
XLV650 Transalp ('00 & Later)		X		X	
XRV650 Africa Twin		X		X	
XRV750 Africa Twin ('96 & Later)		X	X [†]	X	
Kawasaki	R	T	V	VT	XC
Concours GTR1000 ('07 & Earlier)		X			
Concours GTR1400 ('08-'12)			X	X	
ER6F ('06-'12)	X	X		X	X
KLR650E ('08-'12)		X		X	X
KLR650A, ('87-'07)		X		X	
Ninja 250R ('08-'12)		X			
Ninja 500R/GPZ500S ('93 & Earlier)		X			
Ninja 500R/GPZ500S ('94-'10)		X			
Ninja 650R ('06-'08)	X	X	X		
Ninja 650R ('09-'12)	X	X	X		
Ninja 1000 ('11-'12)	X				
Versys 650 ('06-'12)		X		X	X
Z750S ('05-'06)	X	X			
Z1000 ('03-'06)		X		X	
Z1000 ('07-'12)	X	X		X	
ZR7S	X	X	X		
ZRX1100 / ZRX1200R	X	X	X		
ZX10 ('03 & Earlier)	X				
ZX10R Ninja ('04-'05)	X	X			
ZX10R Ninja ('06-'07)	X				
ZX10R Ninja ('08-'10)	X				
ZX10R Ninja ('11-'12)	X				
ZX12R Ninja ('02 & Later)	X	X		X	
ZX6E 93 ('02 & Later)					
ZXR600 ('03-'04)	X	X			
ZX6R ('00-'02) / ZZR600 ('05-'07)	X	X		X	
ZX6RR / ZX6R 636 Ninja ('03-'04)	X			X	
ZX6RR / ZX6R 636 Ninja ('05-'07)	X				
ZX6 ('08-'10)	X				
ZX7R / ZX7RR	X	X			
ZX9R Ninja ('00 & Later)	X	X			
ZZR1200 ('02-'05)	X	X	X		
ZX14R/ZZR1400 Ninja ('06-'12)	X	X			
KTM	R	T	V	VT	XC
990 SuperDuke				X	

Moto Guzzi	R	T	V	VT	XC
V11 Le Mans				X	
Suzuki	R	T	V	VT	XC
DR650SE		X		X	X
DL650 V-Strom ('04-'11)		X		X	X
DL650 V-Strom ('12)		X		X	X
DL1000 V-Strom ('02-'03)				X	
DL1000 V-Strom ('04-'12)		X		X	X
GSF650S Bandit ('05 & Later)	X	X		X	
GSF1200S Bandit ('06 & Later)	X	X		X	X
GSF1250S Bandit ('07-'09)	X	X	X	X	X
GSX1250FA ('10-'12)	X		X	X	X
GSX600F Katana ('98 & Later)		X			X
GSX600F ('08 & Later)		X		X	X
GSX750S Katana					
GSX750F Katana ('98 & Later)		X			
GSX1100 EF		X			
GSX1100S Katana					
GSXR600 ('01-'03)		X	X		
GSXR600 ('04-'05)		X			
GSXR600 ('06-'07)		X			
GSXR600 ('08-'12)		X			
GSXR750 R Limited		X	X		
GSXR750 ('98-'99)		X	X		
GSXR750 ('00-'03)		X	X		
GSXR750 ('04-'05)		X			
GSXR750 ('06-'07)		X			
GSXR750 ('08-'12)		X			
GSXR1000 ('01-'02)		X	X		
GSXR1000 ('03-'04)		X			
GSXR1000 ('05-'06)		X			
GSXR1000 ('07-'08)		X			
GSXR1000 ('09-'12)		X			
GSXR1100 W ('95 & Later)		X	X		
GSX1300R Hayabusa ('99-'07)		X	X	X	
GSX1340R Hayabusa ('08-'12)		X	X	X	
GSX650F ('08-'12)			X	X	
SV650S ('03-'10)		X		X	
SV1000S ('03-'10)		X		X	
TL1000R		X	X		
TL1000S		X	X		
Triumph	R	T	V	VT	XC
Daytona T595 / 955i ('00 & Earlier)		X	X		
Daytona T595 / 955i ('01-'03)		X	X		
Daytona 900 / 1200 ('96 & Earlier)		X			
Daytona 1000 ('96 & Earlier)		X			
Sprint RS 955 ('99-'04)		X	X		
Sprint ST 955 ('99-'04)		X	X		
Sprint ST 1050 ('05-'10)		X	X	X	X
Tiger 1050 ('07-'12)		X		X	X
Tiger 800 & 800XC ('11-'12)					X
Yamaha	R	T	V	VT	XC
FJR1300 ('01-'05)				X	
FJR1300 ('06-'12)				X	
FZ6 S2 ('07-'12)		X	X	X	X
FZ1 ('01-'05)		X	X	X	X
FZ1 Fazer ('06-'12)		X	X	X	X
GTS1000		X			
Majesty 400				X	
T-MAX 500 ('08-'12)					X
TDM900 ('02-'12)		X	X	X	
XT1200Z Super Tenere ('10-'12)		X		X	X
YZF750R		X	X		
YZF750SP		X	X		
YZF R6 ('03 & Later)		X			
YZF R1 ('02-'12)		X	X		

Styles and Colors:

RO = RoadShield

HI = HighwayShield*

CU = CustomShield*

VNB = VarioScreen for Naked Bikes*

VNB = RacingScreen for Naked Bikes*

VTNB= VarioTouringScreen for Naked Bikes

SPS = SpeedScreen

* = available in clear or smoke gray only

Mounting Kits:

Unless marked with one of the codes below, all bikes must use a universal "HK" mounting kit (sold separately)

1 = HKS fitting kit required for BMW R850R & R1100R

2 = HASP fitting kit required for Suzuki SV650 & SV1000

3 = HKSD fitting kit for Ducati Diavel



Aprilia	RO	HI	CU	VNB	RNB	VTNB	SPS
125 Classic	X	X	X	X	X	X	X
MX 125 Supermoto	X	X	X	X	X	X	X
BMW	RO	HI	CU	VNB	RNB	VTNB	SPS
F800R					X	X	X
R80 / R100	X	X	X	X	X	X	X
R80R Classic / Mystic	X	X	X	X	X	X	X
R100R Classic/Mystic	X	X	X	X	X	X	X
R850C	X	X	X	X	X	X	X
R850R Comfort	X	X	X	X		X	X
R850R -96 ¹	X	X	X	X		X	X
R850R 97- ¹	X	X	X	X		X	X
R1100R -96 ¹	X	X	X	X		X	X
R1100R 97- ¹	X	X	X	X		X	X
R1150R	X	X	X	X	X	X	X
R1200C	X	X	X	X	X	X	X
R1200R	X	X	X	X	X	X	X
Cagiva	RO	HI	CU	VNB	RNB	VTNB	SPS
Raptor 650	X	X	X	X	X	X	X
Raptor 1000	X	X	X	X	X	X	X
Ducati	RO	HI	CU	VNB	RNB	VTNB	SPS
696 Monster	X	X	X	X	X	X	X
Diavel 1200						X	
Monster 600, 620, 800 & 1000	X	X	X	X	X	X	X
Hypermotard	X	X	X	X	X	X	X
Harley-Davidson	RO	HI	CU	VNB	RNB	VTNB	SPS
Dyna FXD models	X	X	X	X	X	X	X
Softail FSXT & FLS models	X	X	X	X	X	X	X
Sportster XL 883	X	X	X	X	X	X	X
Sportster XL 1200	X	X	X	X	X	X	X
Honda	RO	HI	CU	VNB	RNB	VTNB	SPS
CA125 Rebel ³	X	X	X	X	X	X	X
XR 125 L	X	X			X		
CB 250 Two Fifty Nighthawk ³	X	X	X	X	X	X	X
CMX 250 Rebel	X	X	X	X	X	X	X
599 (CB600 Hornet)	X	X	X	X	X	X	X
CB750 Nighthawk	X	X	X	X	X	X	X
919 (CB900 Hornet)	X	X	X	X	X	X	X
CB1000R	X	X	X	X	X	X	X
F6C Valkyrie	X	X	X	X	X	X	X
VF 750 C / DC Magna	X	X	X	X	X	X	X
VT 500 C Shadow	X	X	X	X	X	X	X
VT 600 C Shadow / VLX Deluxe	X	X	X	X	X	X	X
VT 750 C Shadow	X	X	X	X	X	X	X
VT 750 C2 American Classic	X	X	X	X	X	X	X
VT 1100 C Shadow	X	X	X	X	X	X	X
VT 1100 C2 American Classic	X	X	X	X	X	X	X
VT 1100 C3 Shadow	X	X	X	X	X	X	X
VT 1300	X	X	X	X	X	X	X
VT 1800	X	X	X	X	X	X	X

Hyosung	RO	HI	CU	VNB	RNB	VTNB	SPS
Aquila 125	X	X	X	X	X	X	X
Aquila 250	X	X	X	X	X	X	X
Aquila 650	X	X	X	X	X	X	X
GT 125	X	X	X	X	X	X	X
GT 250	X	X	X	X	X	X	X
GT 650	X	X	X	X	X	X	X
Kawasaki	RO	HI	CU	VNB	RNB	VTNB	SPS
Eliminator 125, 250, 600 & 900	X	X	X	X	X	X	X
EN 500 Virago	X	X	X	X	X	X	X
ER 5	X	X	X	X	X	X	X
ER6N	X	X	X	X	X	X	X
KFX 50 / 400 / 700	X	X	X	X	X	X	X
KLX 650	X				X		
LTD 450	X	X	X	X	X	X	X
VN 750 Twin	X	X	X	X	X	X	X
VN 800/Classic / Drifter	X	X	X	X	X	X	X
VN 900 Classic	X	X	X	X	X	X	X
VN 1500 / Classic / Drifter	X	X	X	X	X	X	X
VN 1500 Mean Streak	X	X	X	X	X	X	X
VN 1600 Classic	X	X	X	X	X	X	X
W 650	X	X	X	X	X	X	X
Zephyr 550	X	X	X	X	X	X	X
Zephyr 750	X	X	X	X	X	X	X
Zephyr 1100	X	X	X	X	X	X	X
ZL 600 / 900 Eliminator	X	X	X	X	X	X	X
ZR 7	X	X	X	X	X	X	X
KTM	RO	HI	CU	VNB	RNB	VTNB	SPS
950 Supermoto	X	X	X	X	X	X	X
Moto Guzzi	RO	HI	CU	VNB	RNB	VTNB	SPS
Griso 850, 1000	X	X	X	X	X	X	X
Nevada 750 / Classic	X	X	X	X	X	X	X
Sachs	RO	HI	CU	VNB	RNB	VTNB	SPS
4 Rock 250	X	X	X	X	X	X	X
Mad Ass 125	X	X	X	X	X	X	X
Roadster 650 / 800	X	X	X	X	X	X	X
Suzuki	RO	HI	CU	VNB	RNB	VTNB	SPS
DR350S	X				X	X	X
DR650SE	X				X	X	X
DRZ400 & DRZ400SM	X	X	X	X	X	X	X
GS500E	X	X	X	X	X	X	X
GSF 400 N Bandit	X	X	X	X	X	X	X
GSF 600 N Bandit	X	X	X	X	X	X	X
GSF 650 N Bandit 05-	X	X	X	X	X	X	X
GSF 1200 N Bandit (all)	X	X	X	X	X	X	X
GSF 1250 N Bandit	X	X	X	X	X	X	X
GZ125 & GZ25	X	X	X	X	X	X	X
LS650 Savage / S40 Boulevard	X	X	X	X	X	X	X
SV650 naked (all years) ²	X	X	X	X	X	X	X

Suzuki (continued)	RO	HI	CU	VNB	RNB	VTNB	SPS
SV1000 naked 03- ²	X	X	X	X	X	X	X
SFV650 Gladius	X	X	X	X	X	X	X
Van Van 125	X	X	X	X	X	X	X
VL 125 / 250 / 800 / 1500 Intruder	X	X	X	X	X	X	X
VS 800 / 1400 Intruder	X	X	X	X	X	X	X
Boulevard (all models)	X	X	X	X	X	X	X
VX 800	X	X	X	X	X	X	X
VZ 800 / 1600 Ma-rauder	X	X	X	X	X	X	X
Triumph	RO	HI	CU	VNB	RNB	VTNB	SPS
Adventurer	X	X	X	X	X	X	X
America & Bonneville America	X	X	X	X	X	X	X
Bonneville/T100	X	X	X	X		X	X
Legend TT	X	X	X	X	X	X	X
Scrambler 900	X	X	X	X	X	X	X
Speedmaster 800	X	X	X	X	X	X	X
Thunderbird 900 / Sport	X	X	X	X	X	X	X
Thruxtion	X	X	X	X	X	X	X
Trident 750 / Trident 900	X	X	X	X	X	X	X
Yamaha	RO	HI	CU	VNB	RNB	VTNB	SPS
DT 125 R / RE / X	X				X		
SR 125 / 500	X	X	X	X	X	X	X
TT 600 E/S	X				X		
TW 125	X	X	X	X	X	X	X
V Max	X	X	X	X	X	X	X
WR250X / WR250R	X	X	X	X	X	X	X
XJ 600 N / 650 / 750 naked models	X	X	X	X	X	X	X
XT125, XT500, XT600E	X				X		
XV 750 SE Virago	X	X	X	X	X	X	X
XV 125 / 250 / 535 / 750 Virago	X	X	X	X	X	X	X
XV 1000 / 1100 Virago	X	X	X	X	X	X	X
XV 1600 / Road Star	X	X	X	X	X	X	X
XV 1700 Road Star Warrior	X	X	X	X	X	X	X
XV 1900 Midnight Star	X	X	X	X	X	X	X
XVS 125 / 250 V-Star	X	X	X	X	X	X	X
XVS 650 V-Star & V-Star Classic	X	X	X	X	X	X	X
XVS 1100 V-Star & V-Star Classic	X	X	X	X	X	X	X
YBR 125	X				X	X	X





MEFO Dual-Sport Tires

MEFO's long-distance dual-sport tires are world renown for providing an impressive combination of off-road grip, on-road cornering performance, wet weather traction, and outlasting typical dual sport and knobby tires by thousands of miles.



Stone Master Rear

The Stone Master is the knobbyest street-legal tire available just about anywhere.



If you need street legal tires for commuting but can't resist careening down every muddy, rocky, sandy path you encounter, this is the tire for you. The stiff carcass handles very predictably in all conditions, on and off the road, and gets outstanding mileage for a knobby. The open block profile for the tire provides good grip on cross country tracks with stable handling on hard surfaces and pavement.

Rated to 105 mph (170 kmh).
DOT-approved.

Starting At
\$126⁵⁰

MX Master Front

The ideal knobby front tire for use with a Stone Master Rear Tire.



Giving good mileage, on- and off-road handling, and directional stability.

Rated to 112 mph (180 km h)
DOT-approved.

MX Master / Stone Master - Sizes		
Front	Rear	
90/90-21	120/90-17	4.10-18
3.00-21	4.60-17	110/100-18
80/100-21	130/80-17	120/90-18
	5.10-17	130/80-18
	140/80-17	140/80-18
	3.50-18	



Explorer

The long distance dual-sport tire.



Customers have reported to us that a set of Explorers can routinely take about 7,000-9,000 miles of use under the harsh adventure-touring conditions of Alaska. With secure, stable handling on dirt or wet pavement and high mileage performance, the Explorer has excellent all around versatility. Recommended for 50% street and 50% dirt riding. A great tire that will go anywhere and get you home!

Rated to 118mph (190 km h).
DOT-approved.

Starting At
\$126⁵⁰

Explorer - Sizes		
Front	Rear	
100/90-19	120/90-17	120/90-18
2.75-21	4.50/4.60-17	4.00-18
90/90-21	130/80-17	130/80-18
3.00-21	5.10-17	4.60/5.10-18
80/100-21	4.10-18	140/80-18
	110/80-18	150/70-18
	120/80-18	

Gravel, Dirt, Backroads, Interstates, and Track Days
- Twisted can skin ya!





Avon's long history and heritage of innovation reaches back more than 100 years. Based in Melksham, England, Avon tires are built to perform and are engineered to high standards incorporating the latest in cutting-edge technology.

Tire changing and balancing is available at our retail store in Exeter, RI. Stop by on your way to Maine, Nova Scotia, and beyond! Scan here for directions & hours. ▶



Distanzia

The all-rounder for trail and dual-sport bikes



- Specially designed for on-road performance with limited off-road use.
- Engineered to cope with the loads of a sport-touring motorcycle.
- Superb all weather grip.
- Gives excellent mileage.

Distanzia - Sizes	
Front	Rear
80/90-21 48S	110/80-18 58S
90/90-21 54T	120/90-17 64S
90/90-21 54H	120/80-18 62S
100/90-19 57H	130/80-17 65T
110/80-19 H	130/80R17 65H
120/70R17 58H*	150/60R17 66H*
	160/60R17 69H*
	4.00-18 64S
	4.10-18 60S
	4.60-18 63S

*= race compound supermoto tire



Azaro-ST

High mileage sports-touring motorcycles



- Specially designed for high performance and extended tire life.
- Engineered to cope with the loads of a sport-touring motorcycle.
- Superb all weather grip.
- Gives excellent mileage.

Azaro - Sizes
Front
110/80R19 59V

Storm 2 Ultra

High Mileage Sport Touring Tire



- An evolution of the award winning Storm-ST offering more mileage and grip.
- Multi-compound Super Rich Silica (SRS) treads give rear tires up to an extra 12% mileage.
- New technology is incorporated in the zero degree belting system and dynamic stresses within the carcass have been tuned.
- This new technology not only increases mechanical grip and gives improved traction, but also enhances handling and ride comfort.

Storm 2 Ultra - Sizes	
Front	Rear
120/60ZR17 55W	150/70ZR17 69W
120/70ZR17 58W	160/60ZR17 69W
120/70R18 59W	170/60ZR17 72W
	180/55ZR17 73W
	190/50ZR17 75W



VP2 Sport

High performance all condition sport road tire



- Outstanding handling characteristics.
- Large footprint at extreme lean angles.
- High performance silica compounds for enhanced wet grip.
- Ideal for high performance bikes
- Tri-compound for enhanced durability.

VP2 Sport - Sizes	
Front	Rear
120/70ZR17 58W	180/55ZR17 73W
	190/50ZR17 73W
	190/55ZR17 75W*
	200/50ZR17 75W

CALL FOR PRICE on Avon Tires



A = Azaro X+=with tube



					MX Master		Stone Master		Explorer		Distanzia		Azaro and Storm 2 Ultra		VP2 Sport	
					Front	Rear	Front	Rear	Front	Rear	Front	Rear	Front	Rear	Front	Rear
Aprilia																
Dorsoduro, Shiver, Mana, RSV Mille /R/SP, SL Falco/R			120/70 ZR17	180/55ZR17									X	X	X	X
1000R Tuono	2003	2011	120/70 ZR17	190/50ZR17									X	X	X	X
BMW					Front	Rear	Front	Rear	Front	Rear	Front	Rear	Front	Rear	Front	Rear
F650 GS	2000	2007	100/90-19	130/80R17		X	X	X	X	X	X					
F650 GS	2008	2012	110/80R19	140/80 R17		X+			X	X						
F650 GS Dakar	2001	2007	90/90-21	130/80-17	X	X	X	X	X	X						
G650 X - Moto	2006		120/70 ZR17	160/60ZR17					X	X				X	X	
G650 GS	1999	2012	100/90-19	130/80R17		X	X	X	X	X						
G650 X - Country	2006		100/90-19	130/80R17		X	X	X	X	X						
F800 S /ST /R	2008	2012	90/90-21	150/70R17	X	X	X	X	X	X			X	X	X	X
F800 S /ST /R	2006		120/70 ZR17	180/55ZR17									X	X	X	X
S1000RR	2010	2012	120/70 ZR17	190/55ZR17					X						X	X
HP2 Megamoto/ Sport	2009		120/70 ZR17	180/55ZR17									X	X	X	X
K1200R SPORT, K1200RS (5.5" Rear Rim)			120/70 ZR17	180/55ZR17									X	X	X	X
K1200 RS (5" Rear Rim)	1997	2004	120/70 ZR17	170/60ZR17									X	X	X	X
K1200 GT	2003		120/70 ZR17	180/55ZR17									X	X		
K1200 S	2005		120/70 ZR17	190/50ZR17									X	X		
R1200 GS / Adventure			110/80 R19	150/70R17					X	X			A			
R1200 S / R, K1300 S /R			120/70 ZR17	180/55ZR17									X	X	X	X
Buell					Front	Rear	Front	Rear	Front	Rear	Front	Rear	Front	Rear	Front	Rear
XB9, XB12, 1125 CR / R	2008	2009	120/70 ZR17	180/55ZR17									X	X	X	X
Ducati					Front	Rear	Front	Rear	Front	Rear	Front	Rear	Front	Rear	Front	Rear
695 & 696 Monster			120/60ZR17	160/60ZR17									X	X	X	X
749, 848, 999, ST3, 1000SS, 1000 S/ BiPosto/ Classic /GT /LE/S			120/70 ZR17	180/55ZR17										X	X	X
Monster 800 & 1000 S2R / Dark, Testastretta, Monster 1100 /S /EVO /EVO SP			120/70 ZR17	180/55ZR17									X	X	X	X
1000 DS Multistrada / S, 1100 Multistrada /S			120/70 ZR17	180/55ZR17									X	X	X	X
1098 R/ S/ Streetfighter /S, 1198 / S / R, 1200 Multistrada / S			120/70 ZR17	190/55ZR17											X	X
Honda					Front	Rear	Front	Rear	Front	Rear	Front	Rear	Front	Rear	Front	Rear
CRF230 L / F			80/90-21	4.10-18	X	X	X	X	X	X						
CB600 F (599), CB 600 Hornet F / FS			120/70 ZR17	180/55ZR17									X	X	X	X
CBR 600 F4 / F4i / RR / RRR			120/70 ZR17	180/55ZR17									X	X	X	X
XL 600V / 650V Transalp			90/90-21	120/90-17	X	X	X	X	X	X						
XR650L	1992	2012	90/90-21	110/80-18 or 4.10-18	X	X	X	X	X	X						
XRV 650 Africa Twin, XL700 V Transalp			90/90-21	130/80-17					X	X						
VFR800 FI, VTEC, Interceptor, CB100 R			120/70 ZR17	180/55ZR17									X	X	X	X
CBF1000 / GT			120/70 ZR17	160/60ZR17									X	X	X	X
CBR1000 R / RR	2004	2008	120/70 ZR17	190/50ZR17									X	X	X	X
CBR1000 R / RR	2009		120/70 ZR17	190/55ZR17											X	X
XL1000V Varadero	1999	2012	110/80R19	150/70R17					X	X			A	X		
CBR1100XX Super Blackbird, CB1300 F ABS			120/70 ZR17	180/55ZR17									X	X	X	X
Husqvarna					Front	Rear	Front	Rear	Front	Rear	Front	Rear	Front	Rear	Front	Rear
SM400R, 450R			120/70 ZR17	150/60ZR17					X	X					X	X
LT610, SM610 E,R,S TE610			120/70 ZR17	150/60ZR17	X	X	X	X	X	X					X	X
Kawasaki					Front	Rear	Front	Rear	Front	Rear	Front	Rear	Front	Rear	Front	Rear
KL250 Super Sherpa	2000	- 03 & 09	3.00-21 or 90/90-21	4.00-18 or 110/80-18	X	X	X	X	X	X						
250 Super Sherpa	2005	2008	90/90-21	120/90-17	X	X	X	X	X	X						
ER-6 N /F, ZX6 R (636), ZX6 RR			120/60ZR17 or 120/65ZR17	180/55ZR17									X	X	X	X
KLR650 A, E, Tengai, KLR650			90/90-21	130/80-17	X	X	X	X	X	X						



				MX Master	Stone Master	Explorer		Distanzia		Azaro and Storm 2 Ultra		VP2 Sport		
				Front	Rear	Front	Rear	Front	Rear	Front	Rear	Front	Rear	
Kawasaki (Continued)														
Ninja 650R, Versys			120/70 ZR17	160/60ZR17					X	X	X	X	X	X
Z750, Z750S	2004		120/70 ZR17	180/55ZR17							X	X	X	X
Z1000, ZX10 R			120/70 ZR17	190/50ZR17							X	X	X	X
ZX12 R Ninja	2004		120/70 ZR17	200/50ZR17							X	X	X	X
ZZR1200	2002	2005	120/70 ZR17	180/55ZR17							X	X	X	X
ZX-14, GTR 1400 Concours			120/70 ZR17	190/50ZR17							X	X	X	X
KTM				Front	Rear	Front	Rear	Front	Rear	Front	Rear	Front	Rear	
625 SMC, 690 LC4 Supermoto / R / SMC Duke			120/70 ZR17	160/60ZR17					X	X	X	X	X	X
950 & 990 Supermoto / R, 990 Super Duke /R, 1190RC8	2005		120/70 ZR17	180/55ZR17									X	X
Moto Guzzi				Front	Rear	Front	Rear	Front	Rear	Front	Rear	Front	Rear	
850 Brevia, Griso, Norge, 940 Belagio	2007		120/70 ZR17	180/55ZR17							X	X	X	X
1100 Brevia, Griso	2004		120/70 ZR17	180/55ZR17							X	X	X	X
1200 Sport, Norge T / GT, Brevia V1200, 1200 Griso	2007		120/70 ZR17	180/55ZR17							X	X	X	X
Suzuki				Front	Rear	Front	Rear	Front	Rear	Front	Rear	Front	Rear	
DR-Z400 S/E	2000		90/90-21	120/80-18 or 4.60-18	X	X	X	X	X	X				
GSF 600, N, S, U, SU Bandit	2000		120/60ZR17	160/60ZR17							X	X	X	X
GSR 600	2004		120/70 ZR17	180/55ZR17							X	X	X	X
GSF650 S Bandit	2005	2006	120/70 ZR17	160/60ZR17							X	X	X	X
GSF650 A / S Bandit	2007		120/70 ZR17	160/60ZR17							X	X	X	X
Gladius 650F	2008		120/70 ZR17	160/60ZR17							X	X	X	X
DL650 V-Strom	2004	2012	110/80R19	150/70R17					X	X	A	X		
DR650 SE	1990	2010	90/90-21	120/90-17	X	X	X	X	X	X				
SV650 (All)	2003		120/60ZR17	160/60ZR17							X	X	X	X
GSX-R750	2000		120/70 ZR17	180/55ZR17							X	X	X	X
SV1000 S	2003		120/70 ZR17	180/55ZR17							X	X	X	X
DL1000 V-Strom	2002	2012	110/80 R19	150/70R17					X	X	A	X		
GSX-R1000	2001		120/70 ZR17	190/50ZR17							X	X	X	X
GSF1200 S, Bandit	2001	2007	120/70 ZR17	180/55ZR17							X	X	X	X
B-King	2008		120/70 ZR17	200/50 ZR17							X	X	X	X
GSX1300R Hayabusa	1999		120/70 ZR17	190/50ZR17							X	X	X	X
Triumph				Front	Rear	Front	Rear	Front	Rear	Front	Rear	Front	Rear	
Daytona 675 Triple	2006		120/70 ZR17	180/55ZR17							X	X	X	X
675 Street Triple	2008		120/70 ZR17	180/55ZR17							X	X	X	X
675 Street Triple R	2009		120/70 ZR17	180/55ZR17							X	X	X	X
900 Scrambler	2006		100/90-19	130/80R17					X	X				
Tiger 800	2011		110/80 R19	150/70 R17					X			X		
Tiger 800XC	2011		90/90 ZR21	150/70 R17								X		
Tiger 1050	2007		120/70 ZR17	180/55ZR17							X	X	X	X
Tiger 1200 Explorer	2012		110/80 R19	150/70 R17	X		X		X			X		
Speed Triple 1050	2005		120/70 ZR17	180/55ZR17							X	X	X	X
Sprint ST 1050	2005		120/70 ZR17	180/55ZR17							X	X	X	X
Yamaha				Front	Rear	Front	Rear	Front	Rear	Front	Rear	Front	Rear	
WR125 R	2009		80/90-21 or 2.75-21	110/80-18 or 4.10-18					X	X				
XT125 R	2004		90/90-21	120/80-18 or 4.60-18					X	X				
XT250	2008		80/90-21 or 2.75-21	4.60-18	X	X	X	X	X	X				
FZ6 / Fazer / S2	2004		120/70 ZR17	180/55ZR17							X	X	X	X
FZ6R	2009		120/70 ZR17	160/60ZR17							X	X	X	X
YZF-R6 / S	2005	2012	120/70 ZR17	180/55ZR17							X	X	X	X
XT660 X	2004		120/70 ZR17	160/60ZR17					X	X			X	X
FZ1	2006		120/70 ZR17	190/50ZR17							X	X	X	X
YZF-R1	1998	2008	120/70 ZR17	190/50ZR17							X	X	X	X
YZF-R1	2009	2012	120/70 ZR17	190/55ZR17									X	X
FJR 1300A /AS/AE	2001	2012	120/70 ZR17	180/55ZR17							X	X	X	X

A = Azaro X+ = with tube

We base our tire suggestions on publicly-available information on original rim and tire sizes. Always verify that any tire you install spins freely on your bike at all suspension positions without rubbing on any body or frame parts BEFORE riding. Twisted Throttle is not responsible for errors/omissions on this page or for any damage or injury subsequent to use of a suggested tire.



Stop & Go is the originator of the first complete roadside motorcycle tire repair kit and the brand most asked for by name - and with good reason. Pocket Tire Plugger Kits offer a lightweight, compact solution for roadside tire repairs. With innovative tire repair options for both tubed and tubeless tires, Stop & Go will get you on the road again in no time!



Pocket Tire Plugger Kit for Tubeless Tires

The revolutionary Power Plugger device allows you to easily install a mushroom-shaped rubber plug into any tubeless tire without removing the tire from the wheel. With a turn of the included hex wrench, the Power Plugger drives the plug into the offending hole. Once the plug is inserted, inflate the tire, and the plug expands under pressure to fill the punctured area. A firm pull on the plug stem with your pliers seats the mushroom head on the inner wall, allowing no air to escape. This technology insures maximum reliability while reducing your downtime in any situation, without the use of messy liquid glues!

Includes:

- Nozzle
- Tire Plugging Device
- Probe Tool
- Reamer/Rasp Tool
- Hex Wrench
- (15) Mushroom Plugs (5/16" diameter shaft x 3/4" length stem)
- Retractable Razor Knife
- Extra Zip Lock Bag
- Laminated Instructions
- Vinyl Zippered Pouch (7.5" x 3.5" x 1") is smaller than a 4 oz. bag of tasty beef jerky and fits under most motorcycle seats
- Weighs only 12 oz!

SNG.1000: **\$31.95**



Automatic Tire Inflation Kit

Each of these four threaded steel canisters contains 16 grams of 100% pure high velocity CO² gas. In just a few seconds, 8-9 lbs. of inflation is discharged into your tire by each canister. The re-usable loss-less valve adapter is solid brass and allows no leakage. ATVs and pocket bikes will generally use just one canister to fully inflate the tire. On a full-size sport or adventure-touring motorcycle tire, it will generally take all four canisters to reach 24 - 32 lbs. of pressure depending on tire size. This kit is for use on motorcycles, scooters, ATVs, golf carts, lawn mowers, and small utility tires.

Includes:

- (4) Steel Canisters containing 16 grams each of 100% pure high-velocity CO₂ gas
- Tire Valve Adapter with brass fittings
- Full Instructions
- Compact Vinyl Zippered Pouch (5" x 3.5" x 1") is about the size of a wallet
- Weighs only 10 oz!

SNG.1090: **\$21.95**



Tire Lever Set (Pair)

These heavy duty tire irons are ideal for emergency tire repair, but are also quite useful for fighting zombies. (If fighting vampires or werewolves, please call to inquire about our garlic-scented silver-plated tire levers.)

PT.TL.5C: **\$23.95**



Tubed Tire Patch Kit

If you have tubed tires, don't worry - Twisted Throttle hasn't forgotten about you. The Tubed Tire Patch Kit includes six patches in three different sizes, rubber cement, and an abrasive pad in a re-sealable zip-lock bag.

SNG.3003: **\$4.95**

Stop & Go Portable Mini-Air Compressor

The Stop & Go Portable Mini-Air Compressor measures only 4" x 2" x 6", making it possible to be carried on virtually any motorcycle, scooter or ATV. The built-in gauge allows you to observe the increased pressure with a reading up to 120 psi. It also comes with a built-in LED light letting you know that it is receiving power and helps you connect to the tire valve after dark. Your motorcycle tire will be fully inflated in less than 10 minutes. You'll also have the ability to fill inflatable balls & camping equipment.

Product Contents:

- Compressor unit 12V
- Built-in LED light
- Built-in gauge 0-120 psi.
- 4 inch tire valve hose
- 66 inch power cord
- 12 inch extension alligator clips
- 36 inch extension lighter adapter
- Sports needle adapter
- Inflatable adapter
- Complete instructions
- Rugged zippered carry case
- Measures 4" x 2" x 6"
- Weight: 14 oz.

SNG.RCP: **\$31.95**



Oxford DigiGauge

The only pressure gauge you'll ever need.

- Precision measuring up to 199.9 PSI/13.8 Bar in 0.1 PSI/BAR increments
- Reads a choice of pressure scales: PSI/BAR/kPa/KG-CM2
- Rotating dual valve system: Schrader and Presta
- Large backlit display for easy reading in the dark
- Bleeder valve button for pressure adjustment

OXF.OF294: **\$26.00**



Mini Foot Pump

Sometimes electricity isn't available and all you have is foot power. That's okay, because the Mini Foot Pump will inflate your tire almost as fast as an electric pump while giving you a bit of exercise.

The Mini Foot Pump comes with a nylon storage bag, standard Schrader valve, a steel needle inflator, a brass Presta adapter, and a plastic needle inflator for air mattresses. Features an aluminum cylinder construction with an O-ring equipped piston.

Mini Foot Pump Features:

- 0 to 140 PSI gauge
- Foot stand locks pump into compressed position, ensuring the smallest footprint possible - only 5.75" tall x 3.5" wide x 2-5/8" deep!
- Only 9 oz. in weight!

MFP.O: Closeout Price! **\$12.50**



Oxford Tool Kit

The Oxford tool kit has a usable selection of tools that fit easily under most motorcycle seats.

- 28 piece set
- Made from high quality carbon steel
- Carry case designed to fit under most rear seats (4" x 7" 1.25")

Components

- Needlenose pliers
- Wire snips
- Driver with philips, flathead, and metric socket bits
- Allen wrenches
- Mini screwdrivers

OXF.OF291: **\$19.99**



SW-MOTECH Bolt, Washer, and Screw Kits

You can't have enough metric hardware around!



STM.ST.680.10000: **\$49.99**



STM.ST.680.10100: **\$34.99**

Hex-socket Metric Screw Kit Grade 8.8 galvanized steel

100 pieces:
(50) 6mm screws and (25) 8mm screws 16 to 45mm long, (25) 10mm screws 20 to 45mm long.

Metric Nut and Washer Kit

80 assorted washers, plus 100 nuts:
(20) 6mm, (20) M6 self-locking, (20) 8mm, (20) 8mm self-locking, (10) 10mm, and (10) 10mm self-locking

interphone

Designed for motorcyclists who travel in pairs or in groups, Interphone's rider communication system has industry-leading features, including a bike-to-bike intercom, Bluetooth cell phone integration, and a Bluetooth stereo music player. Exceptional audio clarity and a wide volume range allow easy communication at highway speeds, even while wearing ear plugs. Best yet, Interphone's long-lasting battery life won't leave you in silent isolation on all-day rides.



Features common to F4 & F5 intercoms:

- A2DP stereo Bluetooth for HD audio
- Certified IP67 waterproof and dust-proof
- Provide clear audio up to 110 mph
- Bluetooth® wireless music/GPS/phone calls
- Automatic intercom muting during phone calls



What's in the Box?

F5 and F4 headset kits include all the parts necessary to set up two helmets (one of which is full face), so you can easily move the head unit between both helmets.

Each headset kit includes:

- 1 Bluetooth head unit.
- 1 boom mic and speakers for installation in a modular, open face, or full face helmet.
- 1 self-adhesive mic and speakers for permanent installation in a full face helmet.
- 2 quick release head unit mounts (1 self-adhesive, 1 clamp-on).
- Wall charger.

Need two headsets?

Save money and speed up installation by purchasing a Twin Kit. Twin Kits provide two factory-paired head units, two mic/speaker kits for full face helmets, and two mic/speaker kits for modular/open face/full face helmets.

F5 - Communication for up to six riders!

The F5 offers full-duplex communication for groups of up to 6 riders. Effective maximum range starts at 0.8 miles between a pair of riders and increases to 1.5 miles for a group of six riders. The full-duplex communication allows all six people to talk at once.

Features:

- Bluetooth® 3.0: longer range, better connection
- 11 hour talk time per charge
- 5 independent buttons: volume up, volume down, next track/station, last track/station, and function
- Head unit responds to voice commands
- Text-to-speech capability (listen to text messages)
- Automatic volume adjustment based on background noise
- DSP noise suppression system
- FM radio (8 station memory and station scan function)
- Backwards-compatible with F4 head units
- Includes one USB charger/sync cable

Additional USB adapter cable:
CUSBINTERPHONEF5: \$12.99

MSRP
\$299⁹⁹*

Single kit: INTERPHONEF5PLJP

MSRP
\$499⁹⁹*

Twin kit: INTERPHONEF5PPLJP

*See website for current price.



Dimensions: 3.5" L x 1.8" W x 0.75" D

F4 - Communication for a pair of riders

The F4 offers reliable, crystal-clear communication for a pair of riders at an excellent price.

Features:

- Bluetooth® technology
- Range of 0.3 miles
- 10 hour talk time per charge
- 3 independent buttons
- Can be paired to a single F4 or F5 head unit
- USB charging cable available (sold separately)

USB adapter cable:
CUSBINTERPHONEF4: \$12.99

MSRP
\$219⁹⁹*

Single kit: INTERPHONEF4PLJP

MSRP
\$399⁹⁹*

Twin kit: INTERPHONEF4PPLJP

*See website for current price.



Dimensions: 3.5" L x 1.8" W x 0.75" D





GoPro HD HERO2 Motorsports Edition

GoPro cameras are the HD video camera of choice with all types of motorsports enthusiasts, track day riders, racers, off-road riders, and adventure tourers who want to share their exploits with friends and family. GoPro HD cameras feature a compact size, easy installation, excellent video quality, and the durability required for use on motorcycles.

\$299.99

GPR.CHDMH.002

The **NEW HD HERO2 Motorsports Edition** is the most advanced GoPro camera yet with the ability to capture 11 megapixel photos at a rate of 10 per sec. In addition to high-quality photos, it also produces professional 1080p video in a full 170° wide angle field of view.

Includes:

- Camera with submersible waterproof housing
- Rechargeable lithium-ion battery
- 5 adhesive mounts
- 1 suction mount
- 2 mounting feet
- 1 pivot arm
- USB cable



Features:

- 11 megapixel sensor
- 2x faster image processor
- 2x sharper glass lens
- Professional low light performance
- Full 170°, medium 127°, narrow 90° field of view in 1080p
- 120 fps WVGA, 60 fps 720p, 48 fps 960p, 30 fps 1080p video
- Full 170° and medium 127° field-of-view photos
- Ten 11-megapixel photos per second burst
- One 11-megapixel photo every 0.5 second time-lapse mode
- 3.5mm external stereo microphone input
- Records to SD memory cards up to 32GB capacity (not included), each of which can hold 4h 21m of 1080p video
- Waterproof housing approximately 2"x 2.5"x 2.75" excluding mounting feet.

Optional Accessories

LCD BacPac™

The LCD BacPac is a removable LCD screen for HD HERO and HD HERO2 cameras so you can easily aim the camera and watch the footage you've taken.

ALCDB.001 \$79.95



Battery BacPac™

The Battery BacPac charges your spare HD HERO and HD HERO2 batteries using the included mini-USB cable. The Battery BacPac can also act as a supplementary battery that plugs into the back of the camera to nearly double record times.

ABPAK.001 \$49.99



WiFi BacPac™ Remote

The Wi-Fi BacPac attaches to your HD HERO2 camera to enable wireless remote control of up to 50 HD HERO2 cameras via the waterproof Wi-Fi Remote or via a smart phone, tablet, or computer running the free GoPro App.

The Wi-Fi BacPac also supports live photo and video streaming to the web wherever Wi-Fi is present. Record one video stream to your HD HERO2's SD card while sending a second video stream via Wi-Fi to your smart-device, computer, or the Web.

The original HD HERO is compatible with the Wi-Fi BacPac and Wi-Fi Remote, however video streaming is not available.

AWIFI.001
Available Early 2012



Extras

Adhesive Mounts

Package includes five 3M™ adhesive mounts; curved or flat.

Curved adhesive mounts:
AACRV.001 \$19.99



Flat adhesive mounts:
AAFLT.001 \$19.99

Extra Battery

Use this lithium-ion rechargeable battery as a spare or a replacement in your HD HERO camera. Provides approximately 2.5 hrs of recording time.



AHDBT.001 \$19.99

Camera Mounts

Camera Adapter

Connects a GoPro camera to a standard tripod.

GTRA30 \$7.99



Handlebar or Crashbar Camera Mount Kit

Fits bars up to 1.25" diameter. Includes 3" extension arm. Requires either a flat adhesive mount or tripod adapter. Note: to use a flat adhesive mount you'll have to remove the threaded stud from the platform included with the mount kit.

RAM-B-149Z-C1U
\$33.18



ADAPTIV™ TECHNOLOGIES



TPX Radar & Laser Detector System 2.0

features a water, shock, and vibration resistant housing. It also includes a fused 12-volt wire harness for direct hookup to your motorcycle battery. TPX detectors have big buttons that are easy to use while wearing bulky motorcycle gloves, a backlit LCD screen that's readable while riding, as well as an LED visual alert so you don't have to take your eyes off the road. The TPX includes a 3.5mm auxiliary audio jack for integration with other audio or communication systems.

- Exceptional radar and laser detection
- Water resistant construction
- Shock and vibration resistant design
- Oversize, backlit control buttons
- Angled, backlit, daylight visible LCD
- LED visual alert included
- Compatible with other communication or audio systems
- Simple installation

TPX Systems have been performance certified by *Speed Measurement Laboratories, Inc.*, an independent laboratory that specializes in testing radar and laser detectors.

The included quick-release adapter plate is compatible with most RAM, Techmount, and SW-MOTEC motorcycle device mounts.

Optional Accessories	Part Number
Wireless Headset	TPX.A-02-01
Automotive mount with 12-volt power cord	TPX.A-05-03

Note: This item cannot be shipped to states and provinces where radar detectors are illegal.

TPX.A-01-01

GPS Units

GARMIN™

- ▶ **Garmin's zumo 220 Motorcycle GPS** is an affordable motorcycle-specific navigator that includes a rugged waterproof (IPX67) case. The zumo 220 features a bright, glove-friendly, 3.5" color touchscreen with information displayed in an easy-to-read format. It's easy on the eyes, whether you're riding in the bright midday sun or a moonless night. The compact zumo 220 motorcycle navigator mounts easily and uses spoken street names sent wirelessly to your Bluetooth®-enabled helmet or headset. Included Bluetooth® receiver enables hands-free calling or GPS headset use, but does NOT include A2DP stereo for streaming music. When held in the powered automotive mount, the GPS's integrated speakers and headset provide hands-free car use. Lane assist with junction view directs you to the preferred lane and shows realistic images of upcoming junctions.

What's in the Box:

- zumo GPS unit
- Pre-loaded City Navigator® NT for North America
- MapSource® City Navigator North America NT DVD (full unlock)
- Motorcycle handlebar mount
- Motorcycle power cable for direct battery connection
- Replaceable battery
- Automotive windshield suction cup mount
- Automotive power cable
- USB cable
- Dashboard disc
- Installation instructions



Garmin zumo 220
4.21"W x 3.35"H
010-00876-00

\$399.99

- ▶ **Garmin zumo 660 Motorcycle GPS**

You'll find all of the same features as the Garmin 220, plus a larger widescreen 4.3" touchscreen, A2DP stereo Bluetooth® for connecting to an iPod or MP3 music player, and a carrying case. Not compatible with Garmin's GXM™ 40 XM antenna.

\$649.99

Garmin Zumo 660
5.3"W x 3.3"H
010-00727-00



- ▶ **Garmin zumo 665 Motorcycle GPS**

The zumo 665 is the same as the zumo 660, but comes standard with the GXM™ 40 XM antenna with magnetic base. Simply add an XM subscription (not included) and receive real-time XM Radio®. Also includes a swanky dust cover for the motorcycle mount.



Garmin Zumo 665
5.3"W x 3.3"H
010-00727-05

\$799.99

Gadget Mounts allow you to attach your cell phone, iPod, XM Radio, or Radar Detector to your motorcycle. Choose from Techmount, SW-MOTECH and RAM mounts. Each offers a different way to mount your gadgets.



Starting At
\$49.95

Techmount Gadget Mounts

are our mid-priced gadget mounting solution. Techmount features a beautifully finished, CNC-machined appearance. These mounts are universal and can hold a device in the center, left, or right of your handlebar area.

Cradles and pouches attach by either directly bolting the cradle or pouch, adding a quick-release adapter, or using a 4-hole AMPS pattern-compatible mount.

For use with:

- All Bags-Connection device pockets (See page 59).
- All RAM, Garmin Zumo, and TomTom Rider device cradles (page 58).
- All other device cradles with an AMPS hole pattern.

Universal Stem Mount



Fits a wide range of Honda, Kawasaki, Suzuki and Yamaha bikes with hollow steering stem nuts.

Universal Handlebar Mount



The Universal Handlebar Mount includes hardware that provides a proper fit on all standard handlebar diameters, including 7/8", 1", 1-1/8", and 1-1/4".

Techmount Quick-Change Adapter

The Quick-Change Adapter allows you to quickly swap the accessory cradle or pouch attached to your Techmount. It slides easily onto any standard Techmount top plate and locks into place with a spring-loaded locating pin. Accommodates any cradle or pouch with a 4-hole AMPS pattern (see pages 58-60).

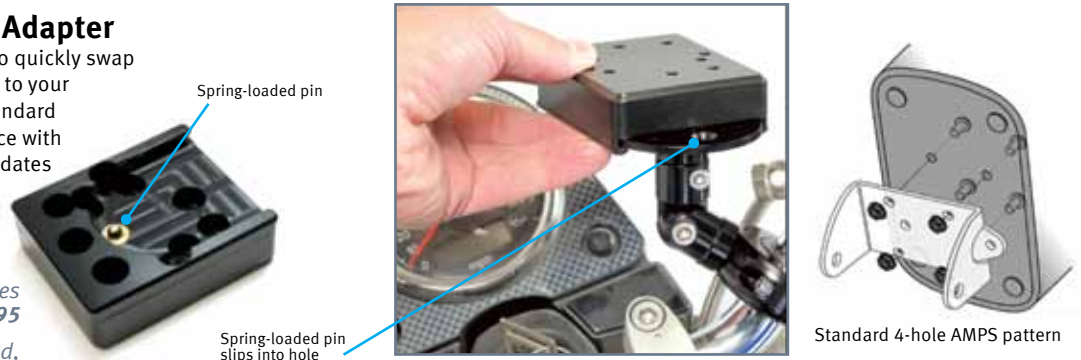

TM.60003: for current round top plates **\$19.95**

TM.60003_OLD: for discontinued, rectangular top plates **\$14.95**



Mounts on handlebar control pinch bolts (clutch or brake side).

Available colors:
silver, black, chrome
(Control mounts and
mirror mounts black only)



Control Mount	10mm Mirror Mount	BMW Mirror Mount
<p>Replaces hand control pinch bolts.</p> <p>TM.31001</p>	<p>Threads into any 10mm x 1.25 standard or reverse threaded mirror hole.</p> <p>TM.31000</p>	<p>Fits into unused mirror holes, left or right side.</p> <p>TM.21004.B</p>

The Control Mount fits a wide range of Harley-Davidson and metric bikes (clutch or brake side). Replaces the two factory pinch bolts with new stainless bolts and spacers on the handlebar controls.

10mm Mirror Mounts are designed to thread into the unused mirror mounting holes found on many metric motorcycles. For use with 10mm x 1.25 standard (brake side) or reverse (clutch side) mirror holes.

The BMW mirror mount takes advantage of the unused BMW handlebar mirror mount holes. This item can be used on both left and right hand sides.

Quick-release Gadget Mounts & Crossbars



SW-MOTECH
BAGS-CONNECTION

Gadget Mounts

SW-MOTECH GPS Mounts are our premium gadget mounting solution, offering a secure fitment and the convenience of easy attachment and detachment. They also feature a vibration-damping mechanism to protect your GPS from the harmful vibes that dual-sport riders encounter.

For use with all Bags-Connection device pockets (see page 59), all RAM, Garmin Zumo, and TomTom Rider device cradles (see page 58), and all other device cradles with an AMPS hole pattern.

Available for 10mm - 12.5mm diameter handlebar crossbars (see below) and for bike-specific applications (see next page).

QUICK-LOCK Vibration-damped GPS Mounts for Handlebar Crossbars

QUICK-LOCK Vibration-damped GPS Mounts for 10mm - 12.5mm diameter handlebar crossbars.

GPS.00.646.10500.B Compatible with most handlebar crossbars, including the SW-MOTECH universal handlebar crossbar (see below) or any other 10mm – 12.5mm diameter crossbar. This includes the original handlebar crossbar on the BMW F650GS and G650GS, as well as the Kawasaki KLR650E (2008 & later).

GPS.07.646.10700.B fits any 16mm - 16.5mm diameter crossbar, including the BMW R1200GS Adventure's original windscreen support bar.



To remove: Push the locking tab forward...



...lift mount upward...

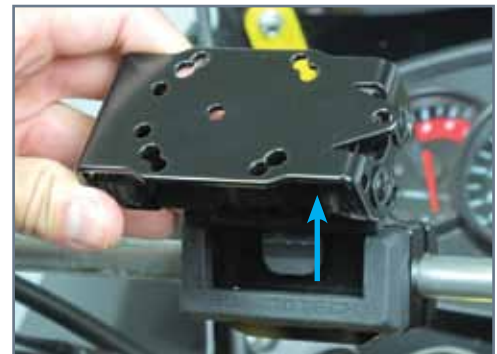

...slide completely off. It takes only seconds!

Handlebar Crossbars

No crossbar? You can add one!

Handlebar crossbar

- 1/2" (12.4mm) diameter x 10-3/4" (273mm) long
- Fits most 7/8" (22mm) & 1-1/8" (28mm) diameter handlebars using the included clamps.
- Verified fit on Suzuki DL1000 and DL650 V-Strom, Triumph Tiger 1050, and many other adventure-touring bikes.
- Available in black or silver.



Suzuki DL650 (Wee-Strom) with Crossbar installed

Bike-specific QUICK-LOCK Vibration-damped GPS Mounts

Starting At
\$79.99

QUICK-LOCK, Vibration-damped GPS Mounts for specific motorcycles.

These mounts are designed for specific motorcycles to provide a custom fit that positions the device near the center of the handlebar, without obscuring the speedometer or other important instruments. Great for GPS devices and other small electronics. For use with all Bags-Connection device pockets (see page 59), all RAM, Garmin Zumo, and TomTom Rider device cradles (see page 58), and all other device cradles with an AMPS hole pattern.



Ultra fast attachment...



...and detachment of the GPS device.



Vibration-damped GPS Mounts	Part Number
BMW G650X	GPS.00.646.10400.B
BMW F800ST	GPS.00.646.10000.B
BMW F800GS and F650GS twin, '08 and later	GPS.07.646.10300.B
BMW R1150GS, R1100GS, and F650GS/Dakar	GPS.00.646.10500.B
BMW R1200GS '08 and later	GPS.07.447.10100.S
BMW K1300GT	GPS.07.646.10200.B
Ducati Multistrada 1200, '10 and later	GPS.22.646.10000.B

*Mounts GPS behind windscreen and above instruments

Vibration-damped GPS Mounts	Part Number
KTM 690 Enduro	GPS.04.436.10000.B
KTM LC4 Adventure, 690 Enduro	GPS.00.646.10400.B
KTM 950 Supermoto, 950 Supermoto R, LC8 990/950 990 Supermoto, 990 Supermoto R, T	GPS.00.646.10400.B
Suzuki DL1000 '04-'12 and DL650 V-Strom '04-'11*	GPS.05.013.10000.B
Suzuki DL650 V-Strom, '12*	GPS.05.646.10200.B
Yamaha FJR1300, '06 and later	GPS.06.646.10200.B
Yamaha Super Tenere, '10 and later	GPS.06.646.10100.B



RAM Mounts offer the widest range of device mounting options for GPS, video cameras, smart phones, and iPods at an affordable price. Choose from several available bases, four arm lengths, and the cradle that matches your device. No matter your needs, there is a RAM Mount solution available! For use with all Bags-Connection device pockets (see page 59) and many types of GPS device cradles (see page 58). You can also mount iPods, toll passes, and other devices using any cradle with a standard AMPS 4-hole pattern.

Gadget Mounts

GPS mounted on RAM Mounting System with Bags-Connection Device Pocket (see page 59).



Record video of your rides safely and securely.



There are three basic components in the RAM Mounting System: Bases, Arms, and Cradles.



What to Order:

STEP 1

Choose Your Base

RAM Mount Bases come in a wide variety of applications, so you will have no problem customizing how you want to display your devices. See next page for more information on RAM Bases.

STEP 2

Choose Your Arm

RAM Mount Arms come in four different lengths: 2", 3", 4.13", and 5.25". See page 58 for information on arms.

STEP 3

Choose Your Cradle

RAM Mount Cradles are available to hold many models of devices. See pages 58 - 60 for information on device cradles and pockets.

STEP 1 Choose Your Base

RAM bases connect directly to your handlebars, mirror mounts, fork stem, and other parts of your bike. They provide the “base” of your RAM mounting system.

Choose one of the bases below to start your RAM Mounting System.

Round flat base plate - 2.5" diameter base



RAM-B-202U \$7.17

Handlebar base with U-bolt for .5" - 1.25" bar



RAM-B-231ZU \$13.95

Base for 1/4" - 20 threaded hole



RAM-B-237U \$8.19

Base for 10mm unthreaded hole (fits most handlebar mirror mounts)



RAM-B-252U \$13.00

Base for 8mm unthreaded hole



RAM-B-272U \$12.95

Base for 6mm unthreaded hole



RAM-B-309-3U \$12.08

Clutch/brake control mount with U-bolt for 1-1/8", 1", 7/8", 3/4" and 0.5" bars



RAM-B-309-7U \$15.97

Offset ball on brake/clutch reservoir cover

Fits many BMW, Honda, Kawasaki, Suzuki, & Yamaha models.



RAM-B-346U \$23.30

Centered ball on brake/clutch reservoir cover

Fits K1200GT, K1200LT, K1200RS, R1150GS, & many other BMWs



RAM-B-345U \$23.81

Fork stem nut base

*RAM-B-342U \$16.59
Fits hollow steering stem nuts with 12, 14, 16, 18, 20 or 28mm Inside Diameter.*



Base for 10mm x 1.25 pitch threaded hole

Thread hole fits many handlebar mirror mounts.



RAM-B-349U \$10.85

Twist & Tilt base for 8mm or 10mm threaded hole

Fits standard handlebar mirror mounts.



Pivots & turns in many directions!

RAM-B-360U: \$22.37

Bike specific kit for Can-Am Spyder Roadster



RAM.30.807.10000 \$14.99

Base for 8mm threaded hole



RAM-B-367U \$11.62

Base for 6mm threaded hole



CPA.00.424.112 \$23.50

STEP 2 Choose Your Arm

Now that you have chosen what base best fits your bike, it is time to choose which length of arm to use. RAM arms connect the base to your device holder and can be pivoted in many directions.

2"
RAM-B-201U-A \$13.52



3"
RAM-B-201U \$13.31



5.25"
RAM-B-201U-C \$20.89



4.13"
Need even more versatility? Try the RAM Variable Swivel Arm.
RAP-B-200-12U \$18.64



Optional RAM Products



RAM-B-230U \$16.18

1" double ball arm connector

This optional double 1" rubber ball adapter allows you to attach two RAM extension arms together. The double ball connector is 1.75" when measured from ball center to ball center.



RAM-KNOB3LU \$22.63

Arm tightener with keyed lock

This optional locking knob replaces the original thumb screw in RAM extension arms. In the locked position, turning the knob will only tighten the extension arm screw. Compatible with 1" receptacles. Provides extra security when leaving electronic devices on your bike!

STEP 3 Choose Your Device Cradle

What do you plan on attaching to your bike? A GPS? Smart phone? iPhone? Or maybe you plan on filming your adventures with a camera? To complete your RAM Mounting System, purchase the cradle adapter below and the appropriate cradle or pocket from pages 58-60.

Step 3a: Buy a cradle adapter...

You need a RAM Cradle Adapter to hold your device cradle or pouch. The cradle adapter will attach to all cradles or pouches that use the industry standard AMPS hole pattern. If you want to mount a camera that uses the standard 1/4" x 20 camera thread, choose the Camera Mount Adapter instead of the Cradle Adapter.

Cradle Adapter
Required with all RAM device cradles. 2.25"x1.25" diamond base.

RAM-B-238U: \$6.76



OR

Camera Mount Adapter
Required for holding a camera 2.5" diameter with 1/4" x 20 threaded stud.

RAM-B-202AU: \$10.24



Step 3b: Choose a Device Cradle

Continue to the next page for more cradle options. →

Choose a GPS cradle from the list below:

Choose a cradle for your device	Part No:
Garmin Nuvi 750 760 770 780	RAM-HOL-GA26U
Garmin 60 & 60C-series GPS	RAM-HOL-GA12U
Garmin Quest-series GPS	RAM-HOL-GA15U
Garmin Nuvi 3XX series	RAM-HOL-GA21U
Garmin Nuvi 6XX series	RAM-HOL-GA23U
Garmin Nuvi 2XX series	RAM-HOL-GA24U
Garmin Nuvi 2XXW series and Nuvi 465T series	RAM-HOL-GA25U
Garmin Nuvi 800 Series (800, 850, 855, 860, 880 and 885T)	RAM-HOL-GA30U
Garmin Nuvi 500 & Nuvi 550	RAM-HOL-GA32U
Garmin E-Trex-series GPS	RAM-HOL-GA5U
Garmin GPSMAP 176, 176C, 196, 276C, & 296 GPS	RAM-HOL-GA7U
Garmin Streetpilot 2600, 2700, and 2800-series GPS units	RAM-HOL-GA9U
TomTom One 2nd & 3rd edition	RAM-HOL-TO4U
TomTom One XL & One XLS	RAM-HOL-TO5U
TomTom ONE 125, ONE 130 & ONE 130S Custom Cradle	RAM-HOL-TO7U

Starting at: \$6.40



STEP 3 Choose Your Device Cradle (continued)

RAM Spring-loaded Device Cradle

Our favorite adjustable/universal cradle for mounting smart phones. The top clamp is spring-loaded and is expandable to safely accommodate larger/taller phones. The side holders are manually adjusted.

Holds devices 4.75" - 6.25" tall x 2.25" - 3.25" wide.

Fits:

- Apple iPhone 3G, iPhone 3G S & iPhone 4
- Blackberry Bold & Storm 2
- HTC Droid Incredible, Evo 4G & G2
- Motorola Droid Pro, Droid 2 & Droid X
- Nokia N8, N900 & X6
- Samsung Galaxy S & Wave
- Windows Phone 7
- iPhones & Smart Phones with skins, sleeves, bumpers and cases

Mounts directly to any RAM-B-238 base, or any Techmount or SW-MOTECH GPS mount.

RAM-HOL-PD3U: **\$14.92**



HR Gripper universal device holder



Friction-fit cradle for mounting video iPods, Blackberrys, and other devices with shapes incompatible with the RAM Device Cradle. Mounts directly to any RAM-B-238 base, or any Techmount or SW-MOTECH GPS mount.

Large - Holds devices 2.4" to 3.6" wide and up to 4.1" tall.

TM.HR2531: **\$39.95**

Small - Holds devices 1.5" to 2.8" wide.

TM.HR1230: **\$34.95**

GPS Pockets and Dry Bags

GPS/PDA Pockets with Sun Visor

Weather-resistant, splash-proof GPS/PDA bags are perfect for navigation devices and smart phones. Bags feature a sturdy base for secure mounting and eyelets to pass-through electrical or audio cables. Mounts directly to a RAM-B-238 base, any Techmount, or any SW-MOTECH GPS mount. iPhone and Android touchscreens can be used through the clear window. The pocket's perimeter zipper makes accessing your device extremely fast, but also makes the pocket somewhat permeable to heavy downpours. If you need a 100% weatherproof solution and don't mind slower entry, use the roll-top GPS Dry Bag.



AMPS pattern fitment

Small Pocket

Fits Apple iPhones, Samsung Nexus, Motorola Atrix, HTC EVO 4G and similar.

Dimensions:
5.3" x 3.5" x 1" deep

BC.GPS.00.004.1000: **\$29.99**



Large Pocket

The large bag provides extra depth for thicker PDAs.

Dimensions:
5.7" x 3.9" x 1.8" deep

BC.GPS.00.002.1000: **\$42.99**



GPS Dry Bag

100% weatherproof (not submersible)
Dimensions: 5.3" x 3.5" x 1.2" deep

BC.GPS.00.005.1000: **\$34.99**

Medium Pocket

Fits Garmin Nuvi 30, 40, 1350, 3750, 2300LM, Tom Tom XXL 540TM, Go2435, Magellen 1424, and similar.

Dimensions:
5.7" x 3.7" x 1.4" deep

BC.GPS.00.003.1000: **\$34.99**



XL Pocket

The extra-large bag provides even more depth compared to the large bag. Fits some XM radios and GPS units.

Dimensions:
5.7" x 3.9" x 3.0" deep

BC.GPS.00.001.1000: **\$47.99**



GPS Dry Bag mounted on GPS mount (GPS mount sold separately).

EZ-Pass/Toll Pass Holder

Our motorcycle toll pass holder is designed specifically to allow motorcyclist the convenience of using the lanes designated "toll pass only" lanes. Made from lightweight and durable ABS resin, the toll pass holder mounts directly to tubular handlebars ranging from 1" to 1.5" diameter. Fits EZ Pass™, M-Tag™, IPASS™, Smart-Tag™, I-Zoom™ and FastLane™. The holder does not work with the FastTrak in CA or the SunPass in FL.

Can also be connected to a RAM-B-231ZU stainless steel U-bolt rail base (see page 57, sold separately).

JSN-011: **\$19.99**



EZ Pass Holder Adapter for 0.5" or smaller bars.
JSN-1/2 **\$3.00**

Waterproof iPhone Case for motorcycles

\$79⁹⁹

GPS.00.646.20000.B

Keep your iPhone protected, dry, and charged with the Biologic iPhone case.

Features:

- Waterproof case protects your iPhone from the elements. Tested to European water protection standard of IPX-4 (splashing water at all angles).
- Touchscreen is usable through the clear touch-sensitive screen membrane.
- “Wake/sleep” and “home” buttons can be used with the phone inside the case; volume buttons and ringer switch cannot be accessed inside the case.
- “Wake/sleep” and “home” buttons can be used with the phone inside the case; volume buttons and ringer switch cannot be accessed inside the case.
- Membrane-protected openings for the rear and front camera lenses let you take video or pictures while you ride.
- Sealed case allows weather-protected access to the stereo jack and dock connector for listening and charging on the go.
- The rotating base allows you to rotate the case into 24 different positions for easy vertical or horizontal viewing.
- The quick-release adapter has an AMPS hole pattern for easy attachment to all RAM, SW-MOTECH, or Techmount gadget mounts.

Waterproof hard case

With touch-sensitive clear membrane.

Includes 2 phone-specific silicone liners
Provides a secure fit and protection to your iPhone 3G, 3Gs, 4, and 4s



Quick-release Adapter

Equipped with AMPS mounting holes. Makes attachment to any gadget mount easy!



To attach your Biologic iPhone case to your bike:

Purchase one of the gadget mounts listed below (sold separately).

RAM Mounts

- Choose a BASE from page 57
- Choose an ARM from page 58
- Choose a RAM-B-238 CRADLE ADAPTER from page 58

Techmount

- Choose from mounts on page 53

SW-MOTECH GPS Mount

- Choose from mounts on page 54 - 55



Touch-sensitive membrane gives you full control over your iPhone when secured in the case.

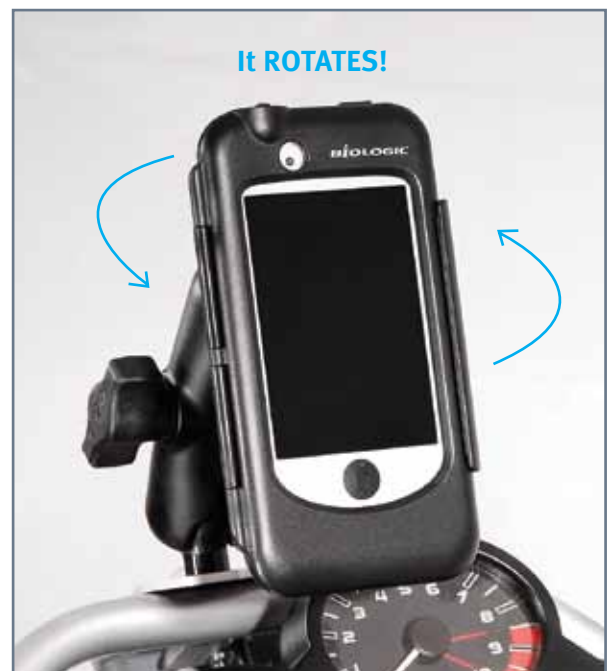

iPhone case ROTATES to accommodate both vertical and horizontal viewing. The back of the waterproof hard case has a rotating base.

Our weatherproof auxiliary power sockets come with a fused battery hookup harness. Sockets can be flush-mounted or handlebar-mounted using the brackets shown below.

12-Volt Mini-Euro Socket (matches the size of BMW and Triumph 12-Volt power ports)



CPA.00.006.100 \$29.99

Handlebar Mount for Mini 12-Volt Socket



For 7/8" handlebar clamps only
CPA.00.006.150 \$22.50



Handlebar mounted 12-Volt Mini-Euro Socket.

12-Volt Cigarette Socket



CPA.00.006.103 \$29.99

Handlebar Mount for 12-Volt Cigarette Socket



22mm (7/8") diameter handlebar clamps CPA.00.006.160 \$22.50
28mm (1 1/8") diameter handlebar clamps CPA.07.006.180 \$22.50



Handlebar mounted for 12-Volt socket.

Additional 12-Volt Socket Accessories

Convertible Mini-Euro/Cigarette Replacement Plug



Fits into mini-Euro sockets and cigarette sockets.
CPA.00.006.102 \$13.99

Mini-Euro-to-Cigarette Socket Converter



Mini-Euro Plug
Cigarette Socket
Cable length 8" CPA.00.006.101 \$24.99
Cable length 40" CPA.00.006.104 \$29.99

USB Charger for Cigarette Socket

This adapter fits inside a cigarette lighter socket and will accommodate a USB charging cable.



BC.POW.00.012.100 \$14.99

Charge Your Electronics In Your Tankbag.

Pass power into tankbag from handlebar socket using wall pass-through



Choose adapters appropriate for the electronics inside your tankbag



STEP 1 Pass power from handlebar socket to the tankbag.

From Cigarette Lighter Socket to Tankbag



From Mini-Euro Socket to Tankbag



From Battery to Tankbag



STEP 2 Pass power through the tankbag wall.

SAE Tankbag Wall Pass-through Kit



Power terminates inside tankbag as SAE connector



SAE connector on the exterior has a weatherproof cap



STEP 3 Distribute power inside the tankbag.

SAE to Single Cigarette Socket



SAE to Dual Cigarette Socket



SAE to Cigarette & Mini-Euro Sockets



Connect SAE adapter to 12-Volt sockets



USB Charger for 12-volt Cigarette Socket

This adapter fits inside a cigarette lighter socket and will accommodate a USB charging cable.



BC.POW.00.012.100: **\$14.99**

Convert cigarette socket into a USB charger



Tapp™ Lite USB Charger

This compact USB Charger is the weatherproof answer to charging most cell phones, GPS units, and MP3 players. It mounts easily to your handlebars or any flat or curved surface using the included self-adhesive mount. A tethered seal cap protects the charger from dust and water. The included fused battery hookup harness is diode protected against reverse polarity.



- Output Current: 1 amp
- Protection Rating: IP64 water wash-down protected when capped
- Cable length: 6ft (2 meters)

3BR.150.0034.01: **\$32.95**

Garmin Mini-USB Charging Cable



This cable allows you to charge your Garmin GPS unit through its mini USB port without forcing the device into the unusable "computer data sync" mode. Right angle adapter is 5" long; 3' coil cable can expand to 6' and ends in a convertible mini-Euro / cigarette plug.

BC.POW.00.003.100: **\$39.99**

Tapp™ Lite Charger USB with Mini-Euro Plug

This USB Charger is used on BMWs with a Mini-Euro socket. This unit charges USB accessories, including cell phones, most GPS units, MP3 players, and some digital cameras. A tethered seal cap protects the charger from dust and water. The Mini-Euro plug makes installation simple. Just attach the TAPP Lite using the Universal Mounting Bracket and plug the Mini-Euro Plug into your bike's power socket. Cable length: 6". Output current: 1 amp.



3BR.150.0042.06: **\$39.95**

Tapp™ Plus USB Charger for iPad

A complete solution designed to power the Apple iPad. Included is a fused wiring harness, a Universal Mounting System, and a USB connector with a power output of 2.1 amps. A tethered seal cap protects the charger from dust and water. Just hook directly to your battery or the Twisted Throttle Power Hub (see page 70), secure the USB connector to an appropriate surface, plug in your iPad and go! Cable length: 6ft (2 meters).



3BR.150.0053.01: **\$44.95**

Tankbag Wall Pass-through kit



The water-resistant pass-through kit enables you to run audio cables or a hydration system through your tankbag wall.

BC.POW.00.007.100: **\$14.99**

Hydration straw pass-through



Headphone pass-through



Denali D1 LED Lighting

Designed specifically for motorcycles.

The tiny 2" cube-shaped lamps contain ultra-bright LEDs with an incredibly low electrical draw of 0.75 amps (10 watts). This means that for the first time, smaller bikes with weak electrical charging systems can use high output auxiliary lighting without draining the bike's battery! This enables larger bikes to run both heated clothing and auxiliary lighting simultaneously.



Denali LEDs are Bright! Despite their low power draw, Denali LEDs generate light output similar to a traditional 55-watt halogen lamp. Denali LEDs create a pure white light that maximizes brightness without losing distance, making them an ideal driving light!

Denali LEDs are Tough! Because LEDs don't have filaments like halogen bulbs, Denali LEDs can withstand much more shock, vibration, and other forms of abuse. The Denali D1s are constructed using a rugged aluminum housing that is impenetrable to dust and submersible up to 3 meters. The unbreakable face plate acts as a radiant heat sink to melt away ice in frigid conditions.

Denali LEDs Last a Long Time! Without ever being shut off Denali LEDs have an average lifespan of over 50,000 hours (6+ years).

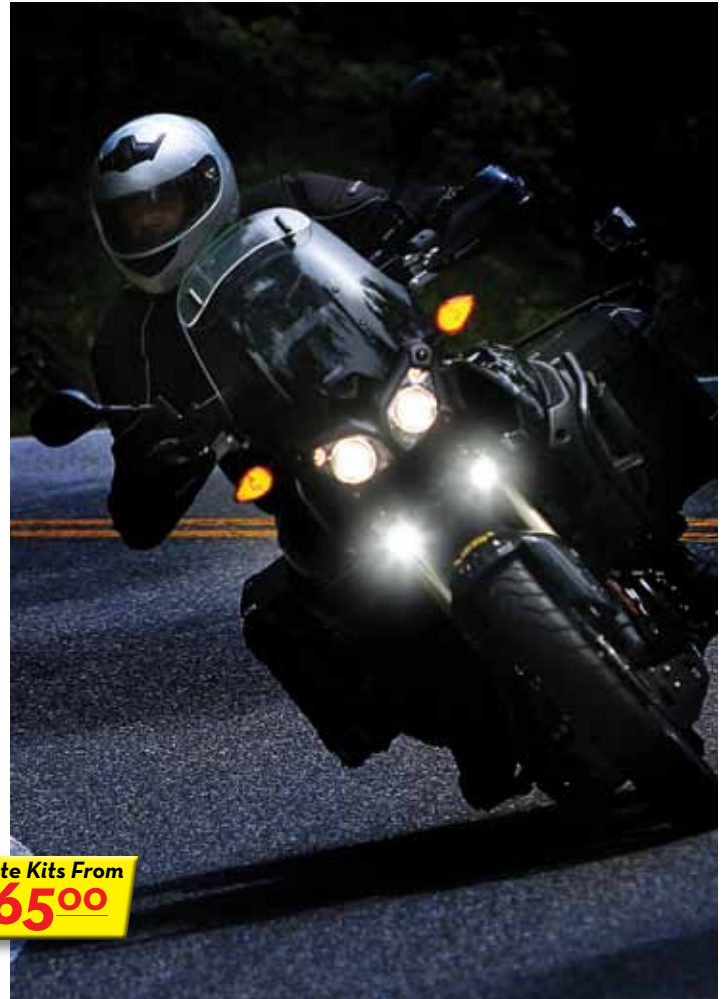

Complete Kits From
\$265.00

TT-D1.KIT

Denali D1 LED Lights

Denali D1 Kit Includes:

- 2 x Denali D1 LED light pods
- Full wiring harness with relay and lighted switch (switch mount sold separately)
- 2 x universal 8mm mounting brackets
- 2 x multi-link connectors
- 2 x spot beam lenses (10 degree beam pattern)
- 2 x flood beam lenses (35 degree beam pattern)
- Installation instructions

Spot and flood lenses included



Easily switch from a spot lens to a fog lens by removing 4 screws.

Interlocking channel design (Denali D1)



Attach up to 4 pods in a row or a grid using a single mounting point.

Denali Lighted on/off Switch



Denali LEDs can be wired to be switched by your high beam or turned on and off independently using our lighted on/off switch.

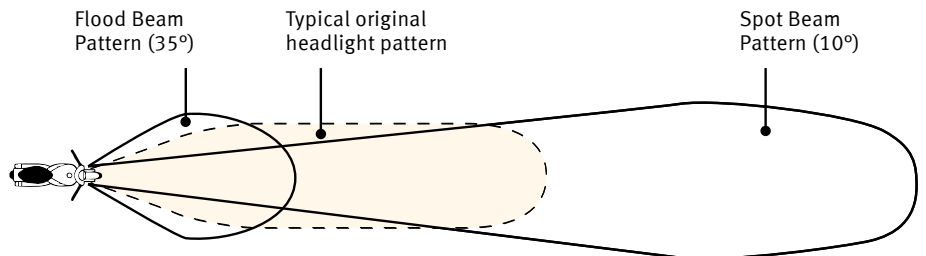

Comparison of spot beam and flood beam patterns to the beam pattern of a typical original headlight. Our Denali kit includes interchangeable spot lenses and flood lenses, so you can use Denali LEDs as driving lights with a narrow, focused beam or as wide-beam flood lights.



SCAN HERE for a video on Denali Lighting!

Denali D2 LED Lighting

When bright isn't bright enough, grab a set of Denali D2 LED lamps.

Denali D2s are even Brighter! Advances in super-swanky LED technology have increased the effective light output of our Denali system by nearly 70% without increasing the electrical power draw to your motorcycle. Consuming only 10 watts (0.83 amps at 12 volts DC) of power per lamp, it throws a blazing beam of light in front of you that is nearly twice as bright as the beam generated by the original D1.



Denali D2s are rugged! The Denali D2 is housed in a rugged waterproof 2" aluminum housing (submersible to 1 meter underwater).

Long lasting! The LED boasts an average life of over 50,000 hours (6+ years) without ever being shut off. Yup, we went overboard, it's what we do.



Denali D2s have the highest light output per watt of energy consumed of any light on the market.

Denali D2D Dual-intensity LED Lights

Too bright? Not with our dual-intensity feature! The Denali D2D can easily be wired to run at 50% brightness until you flick on your high beam switch, unleashing their phenomenal cosmic power at 100% intensity.

Denali D2 Kit Includes:

- 2 x Denali D2 LED Round Light Pods
- Wiring Harness with Dual-intensity Controller and lighted switch
- 2 x Universal 8mm mounting brackets
- Installation Instructions
- 2 x spot beam lenses (10 degree beam pattern)
- 2 x flood beam lenses (25 degree beam pattern)

Complete Kits From
\$359⁹⁹

TT-D2D

NEW

Denali D2S Single-intensity LED Lights

Now you can have the quality of the Denali D2D at a lower price. The Denali D2S has the exact same LEDs as the Denali D2D, but without the dual-intensity feature. The Denali D2S turns on and off using your high beam switch.

Complete Kits From
\$309⁹⁹

TT-D2S

Dual-intensity Wiring Harness Upgrade

Upgrade your Denali D2S kit to have the Denali D2D dual-intensity feature using this wiring harness upgrade.

\$59⁹⁹

TT-D2D.H

Twisted BMW F800GS with the Denali D2 light kit installed



Kawasaki KLR650E (2008 & Later) with Denali D2 lights installed

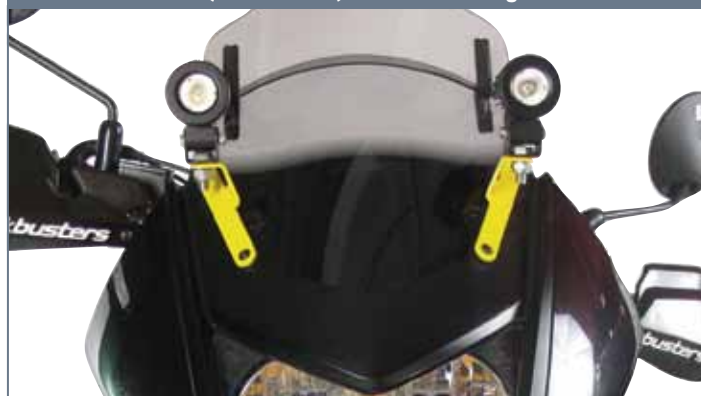

Denali LED lighting mounted on Triumph Tiger 1050 fairing



TWT.LAH.11.007.100

Denali D2 mounted on Suzuki DL650 V-Strom using auxiliary mount bar



LAH.05.456.100

Triumph Tiger 1050 fender mount



Denali LED lighting mounted on Honda Varadero fairing mount



Denali Accessories

Denali D1 Accessories	Notes	Part No.
Denali D1 LED Lighting single pod	Wire harness sold separately.	TT-D1.POD
Dual wire harness with lighted switch for Denali D1	Includes relay & lighted on/off switch.	TT-D1D.H
Y adapter (one light to two) for Denali D1	Allows you to run two Denali LED pods in place of one.	TT-D1.S-DY2M1F

Denali D2 Accessories	Notes	Part No.
Denali D2 LED Lighting single pod	Wire harness sold separately.	TT-D2.POD
Single-intensity wire harness for Denali D2	Includes relay & lighted on/off switch.	TT-D2S.H
Dual-intensity wire harness for Denali D2	Includes relay & lighted on/off switch.	TT-D2D.H
Y adapter (one light to two) for Denali D2	Allows you to run two Denali LED pods in place of one.	TT-D2S.Y

Switch Mounts allow you to mount your Denali switch next to your high beam switch.

BMW:	TM.52002	\$12.95
Harley:	TM.52000	\$9.95
Metric:	TM.52001	\$9.95



Handlebar & Crashbar Mounts

allow mounting to crashbars, handlebars or frame tubes.

21.3 mm, 22mm (7/8"), 25.4mm (1"), 26.9mm and 28mm (1-1/8")
TM.51125 **\$49.95/pair**



Fender Mounts

connect to any threaded M5, M6 or 5/16 hole. Includes spacers to accommodate tight spaces.



5/16" fender bolts:	TT-D1.020.5/16
5mm fender bolts:	TT-D1.020.M5
6mm fender bolts:	TT-D1.020.M6

\$44.99/pair

Hinge Mounts

can be used on a flat surface, bolted through an existing unthreaded hole.

6mm bolt:	TT-D1.P-SHM6
10mm bolt:	TT-D1.P-SHM10

\$4.99/pair



PIAA

High-Performance Replacement Bulbs

Replacement Bulb	Wattage	Part No.
1100X lamp, single	55w	70215
H1, single	55w	70165
H11, single	55w	70555
H3, single	35w	70323
H3, single	55w	70325
H4, single	60w/55w	70456

Looking for higher performance out of your headlights, but not ready to go for an auxiliary light kit? Try out these PIAA Xtreme White replacement bulbs, which offer a whiter beam and higher light output than your original headlight bulbs without drawing more power from your bike's electrical system.

Replacement Bulb	Wattage	Part No.
H4, single, Super Plasma, Anti-Vibration	60w/55w	70476
H6M, single	35w/35w	70023
H7, single	55w	70755
H9, single	65w	70955



Starting At
\$35⁹⁵



SCAN HERE to find out which PIAA bulbs fits YOUR bike.

BMW	from	to	Fairing mount	Fender mount	Fitting notes
F650CS	'02	'06		M5	Lower front fender bolt position
F650GS single	'00	'07		M5	Mounts under front beak
F650GS twin	'08	'12	TM.51005	M5	
F800GS	'08	'12	TM.51005	M5	
F800R	'09	'12		M6	
F800S & F800ST	'06	'12		M6	
G650GS	'09	'11		M5	Mounts under front beak
K1200GT	'02	'05		M5	
K1200GT	'06	'08		M6	
K1200R	'05	'08		M5	
K1200S	'05	'06		M5	Production dates before 03/2006
K1200S	'06	'08		M6	03/2006 & later production dates
K1300GT	'09	'11		M6	
K1300R	'09	'12		M5	
K1300S	'09	'12		M6	
R1150R	'00	'06		M5	Lower front fender bolt
R1150GS	'99	'04	NSW.07.004.10100		
R1150GS Adventure	'02	'05	NSW.07.004.10100		
R1200GS & R1200GS Adventure	'04	'12	TM.51003		Dual light bar can be used to mount up to 2 pairs of lights
R1200GS	'08	'12	NSW.07.563.100		For use with or without SW-MOTECH upper crashbars
R1200RT	'05	'11	LAH.07.817.10000.B	M5	
R1200ST	'05	'09		M5	
S1000RR	'09	'12		M5	
Buell	from	to	Fairing mount	Fender mount	Fitting notes
Lightning XB12S & XB9S	'09	'10		M8	
Ulysses XB12X	'05	'10		M8	
Ducati	from	to	Fairing mount	Fender mount	Fitting notes
749	'04	'07		M6	
999	'03	'07		M6	
Hypermotard	'09	'12		M6	
Monster (all)	'04	'12		M6	
Multistrada (all)	'04	'09		M6	
Multistrada 1200	'10	'12	NSW.22.004.10001.B	M6	
ST2	'98	'07		M6	
ST3	'04	'07		M6	
ST4	'00	'07		M6	
Streetfighter	'09	'12		M6	
Harley-Davidson	from	to	Fairing mount	Fender mount	Fitting notes
Fatboy	all			5/16	
Heritage	all			5/16	
Sportster	all			5/16	
V-Rod	all			M5	M5 fender mount kit can be used on fender bolts; 6mm-diameter fender mount kit can be used on headlight mounting bolt points
Honda	from	to	Fairing mount	Fender mount	Fitting notes
599	'04	'06		M6	
919	'00	'07		M6	
CBR1000RR	'04	'12		M6	
CBR600RR	'04	'12		M6	
CBR1100XX	'96	'07		M6	
Goldwing GL1800	'01	'12		M6	
NT700V	'08	'12		M6	
Shadow (most models)				M6	
Silverwing				M6	
ST1100	'98	'02		M6	
ST1300	'03	'12		M6	
Valkyrie	'97	'07		M5	
VFR800	'02	'12		M6	
VFR1200F	'10	'11	In development		
VTR1000F	'97	'06		M6	
VTX1300	'03	'12		M5	
VTX1800	'02	'12		M5	
Varadero XL1000V	'07	'12	LAH.01.818.10000.B		Fender mount also available
Kawasaki	from	to	Fairing mount	Fender mount	Fitting notes
Concours GTR1000	'86	'07		M6	
Concours GTR1400	'08	'12		M6	
ER6N	'06	'12		M6	
KLR650A	'86	'07		M6	Fender mount kit uses front fairing subframe bolt position. See photo.
KLR650E	'08	'12	TWT.LAH.08.003.100	M6	Fender mount kit replaces side reflectors on forks and requires the 2 original 6mm nuts

Kawasaki (continued)	from	to	Fairing mount	Fender mount	Fitting notes
Ninja 250R	'08	'12		M6	
Ninja 500R	'87	'12		M6	
Ninja 650R	'06	'12		M6	
Versys	'07	'09	NSW.08.004.10100	M6	
Versys	'10	'12	NSW.08.004.10200	M6	
Vulcan (most)	'01	'12		M6	
Z1000	'03	'12		M6	
ZRX1200R	'01	'05		M6	
ZX6R	'00	'12		M6	
ZX10R	'01	'12		M6	
ZX14	'06	'12		M6	
ZZR600	'03	'08		M6	
KTM	from	to	Fairing mount	Fender mount	Fitting notes
950/990 Adventure	'03	'12	NSW.04.004.10000	M6	Fender mount kit fits to fairing
Super Duke	'07	'12		M6	
990 SMT	'09	'12	NSW.04.004.10100		
Suzuki	from	to	Fairing mount	Fender mount	Fitting notes
B-King		'12		M6	
Bandit 650 & 1250	'00	'12		M6	
Burgman 400		'12		M6	
Burgman 650		'12		M6	
Boulevard (most models)	'98	'12		M6	
DR-Z400S & DR-Z400SM		'12		M6	
DR650SE	'96	'12		M6	
Gladius	'09	'12		M6	
GS500F	'04	'12		M6	Fender mount kit replaces original side reflectors on forks
GSX650F	'08	'12		M6	Fender mount kit replaces original side reflectors on forks
GSX1250F	'10	'12		M6	Fender mount kit replaces original side reflectors on forks
GSX-R600	'00	'12		M6	
GSX-R750	'96	'12		M6	
GSX-R1000	'00	'12		M6	
Hayabusa	'99	'12		M6	
SV650 & SV650SF	'99	'12		M6	
SV1000	'03	'12		M6	
TL1000	'97	'02		M6	
V-Strom DL1000	'02	'12	LAH.05.456.100	M6	
V-Strom DL650	'04	'11	LAH.05.456.100	M6	
DL650 V-Strom	'12	'12	LAH.05.456.100	M6	
Triumph	from	to	Fairing mount	Fender mount	Fitting notes
Bonneville	'01	'12		M6	
Rocket III	'04	'12		M6	
Speed Triple	'01	'12		M6	
Sprint ST & GT	'99	'12		M6	
Tiger 1050	'07	'12	TWT.LAH.11.007.100	M6	Fender mount kit bolts to top fender bolt position
Tiger 955	'01	'06		M6	
Tiger 800	'11	'12	In development		
Trophy	'97	'03		M6	
Victory	from	to	Fairing mount	Fender mount	Fitting notes
Kingpin	'05	'12		M6	
Yamaha	from	to	Fairing mount	Fender mount	Fitting notes
FJR1300	'06	'12	LAH.06.816.10000	M6	
FZ1	'01	'12		M5	
FZ6 & FZ6R	'04	'12		M5	
FZ8	'10	'12		M5	
R1	'98	'12		M5	
R6	'99	'12		M5	
Road Star		'12		M5	
Roadliner		'12		M5	
Royal Star		'12		M5	
Stratoliner	'11	'12		M5	
V-Max 1200	'85	'07		M5	
V-Star		'12		M5	
Warrior		'12		M5	
Super Tenere	'10	'12	NSW.06.004.10100		Fender mount in development

Fender Mount	Notes	Part No.
M5	Denali Fender Mount Kit, For M5 Thread	TT.D1.020.M5
M6	Denali Fender Mount Kit, For M6 Thread	TT.D1.020.M6
5/16	Denali Fender Mount Kit, For 5/16x 18 tpi Thread	TT.D1.020.5/16

OXFORD MAXIMISER 360T



SALE PRICE!

\$49⁹⁹

OXF.OF701US

Intelligent 12 volt battery charger won't leave you with a dead battery come spring!

Oxford's smart charger has multiple charging rates that analyze battery condition, check polarity and "float", and maintain a charge for battery longevity. Suitable for all 12-volt motorcycle, car, and truck batteries.

7 stage charging:

1. Tests battery connection polarity.
2. Analyzes your battery and diagnoses condition.
3. Gently recovers even heavily discharged batteries.
4. Quickly charges low batteries.
5. Checks voltage retention.
6. Monitors battery condition.
7. Maintains battery with a low current if the voltage drops below a set limit.

Features:

- Choose from 3 charge rates: MOTORCYCLE (600mA), CAR/TRUCK (3600mA) or BOOST (for AGM batteries and cold weather charging).
- Backlit LCD Display shows real-time charging rate. It shows both battery charge voltage and amperage.
- Battery Condition Adviser shows if the battery is able to hold charge or is in need of replacement.
- Includes alligator clips and a quick-release permanent battery hookup.
- Included wall bracket and extra long cables make for ease-of-use in your garage.

Included wall bracket makes storage easy



Battery Condition Indicator



Alligator clips and battery hookup included



SALE PRICE!

\$19⁹⁹

OXF.OF951US



OXFORD OXIMISER 600

The Oxford Oximiser quickly charges any battery at 600mA/hour until full and maintains a gentle trickle charge to keep battery optimized. Quick-connect leads included for easy coupling to the Oximiser between rides. Extra-long cables make for ease-of-use in your garage.

- Plug-in battery care for 12-volt lead-acid batteries up to 30Ah.
- Suitable for all 12-volt battery types up to 30Ah including: gel, MF, and acid batteries.
- Gently recovers even heavily discharged batteries.
- Protected against short circuit.
- 2 year guarantee.

The Oximiser is suitable for all 12-volt motorcycle batteries, as well as for other applications such as quad-bikes, jet-skis, golf carts, cars, motor homes, caravans, commercial vehicles, and boats.

Kit comes complete with alligator clips to connect the charger, a connector which can be permanently fitted on any motorcycle or car, and a wall-mount holster bracket for easy storage.

NEBO Highbeam™ Rechargeable Flashlight

No Batteries!

The Highbeam is a compact, rechargeable 35 lumen LED flashlight that NEVER needs batteries. It's perfect for casting a soft light for short-distance campsite illumination or nighttime reading. The Highbeam charges in any 12-volt power socket (cigarette lighter) and glows red when charging. Just turn the bezel clockwise to activate the LED, and turn the bezel counter-clockwise to turn off. The Highbeam is constructed with anodized aircraft grade aluminum and is completely weatherproof.

Features

- High-power LED outputs 35 lumens of light (rated for 110,000+ hours of life).
- Anodized aircraft grade aluminum.
- Compact (measures 2.5" long x 0.75" diameter).



shown actual size

Available in Six Colors:



Black

Green

Brown

Pink

Gray

Blue

Weatherproof



LED glows red when charging



\$999

NEB.HB

NEBO REDLINE® Tactical LED Flashlight

NEB.5610

\$3499



NEB.5608

\$3999



Quick-release mount attaches to .87" to 1.25" diameter handlebars.

shown actual size

High-end technology in a compact, extremely powerful light!

The NEBO REDLINE® is exceptionally bright with 220 lumens of pure white light! This is a long distance flashlight bordering on the power of a low power headlight... all in a relatively small package. To put the power of this flashlight in perspective, anything above 50 lumens within a 10 yard distance may cause temporary blindness. Included are 3 AAA batteries.

The flashlight has an adjustable wide angle lens that allows the REDLINE® to shift from a floodlight that illuminates everything within 20 yards, to a spotlight with a 150 yard range.

Features

- LED output is 220 lumens of light
- 0.428 lbs.
- 3 AAA batteries (included).
- 4 hours of runtime at 100% illumination, 8 hours of runtime at 50% illumination.
- Anodized aircraft grade aluminum, compact body design.
- 4.5" long x 1.25" diameter.
- Water-resistant.
- Magnetic base for hands-free lighting.
- Dual-function on-off button glows in the dark.
- **Hard Touch:** If you fully depress the button, the light will turn off between settings. The light will reset to the first setting (100% ON) after being off for 20 seconds.
- **Soft Touch:** If you press the button halfway with no click, you can cycle through the settings quickly without turning off the light between settings.

REDLINE® has 5 lighting modes:

- 100% white light (220 lumens).
- 50% white light (110 lumens).
- 10% white light (22 lumens).
- S.O.S. mode (220 lumens).
- Defensive strobe mode (220 lumens).

The REDLINE® Bike Light

has 3 lighting modes:

- 100% white light (220 lumens).
- 50% white light (110 lumens).
- Defensive Strobe Mode (220 lumens).

Triumph Street Triple (tapered bars) with REDLINE Bike Light



POWERHUB

Fused Power Distribution and Master Ground Block

Avoid the typical under-seat rat's-nest of wiring caused by hooking up multiple electronic devices directly to your battery!

The PowerHub allows you to safely connect up to 6 electronic devices (total simultaneous draw no more than 30 amps) to your motorcycle in a clean, workman-like manner. Each electronic device can be connected so that it is switched on or off automatically with the vehicle, or powered constantly. Each 10-amp circuit is fused and accepts standard mini blade fuses available in any auto parts department. Suitable for both CANbus and standard electrical wiring. Small and easy to install.



\$83⁹⁹

ELC.00.10000

Features:

- 3.3" x 2.4" x 1.4" (about the size of a deck of cards).
- 2 slots for storing spare fuses.
- 6 fused circuits (each rated at 10 amps).
- Detailed installation instructions.
- Each circuit can be switched or un-switched.
- Trigger wire for "switched" side is diode protected for CANbus bikes.

LED Battery Voltage Monitor

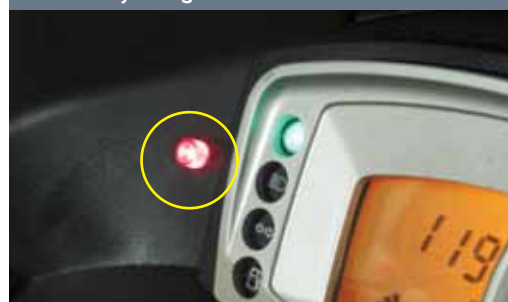

The smallest and simplest monitoring device available! This flush mount kit includes a 1/4" diameter LED that displays voltage levels using colors in a stoplight-style arrangement: **RED** - less than 11.5 volts, **AMBER** - 11.9 to 11.5 volts **GREEN** - 12 volts and up. Fuse protection, wiring, connector assortment and complete instructions are included. Simple 2 wire installation. Drilling a single .25" diameter hole is required to install on any flat surface near your instrument panel.

EC.04101: **\$29.95**

Backlit Thermometer, Voltmeter, and Ammeter



ChargeGuard Multi-Mode Display

ChargeGuard display is a digital multi-meter with 4 modes of display:

- Voltmeter (volts)
- Ampere (amps)
- Ambient temperature (°F or °C)
- Ice Alert

The ChargeGuard is designed for all motorcycles with a 12-volt battery and installation is a simple plug-and-play operation.

Dimensions:
2.35" L x 2.15" H x 1" D



\$149⁹⁵

KIS.CG.25



CANbus Electrical Connector for BMW, Ducati, & Triumph Motorcycles

Many late model European motorcycles use "CANbus" electrical systems that can malfunction if add-on electrical accessories are spliced directly into the wiring harness. Our CANbus adapter provides a "hot" trigger wire, which activates a relay to safely power electrical accessories (driving lights, accessory fuse blocks, GPS, heated grips, etc.) when such motorcycles are turned on. The adapter simply plugs into the bike's existing 194 headlight marker bulb socket. Combined with our PowerHub, the CANbus connector provides a complete solution for installing electrical accessories on CANbus motorcycles.



EC.02350: **\$19.95**

Stebel Dual-tone 139db Nautilus Air Horn

Be Heard!

This Dual-Tone 139dB 12-volt Air Horn is loud enough to convince other drivers that there's a derailed freight train barreling down on them. With the Stebel air horn, there's no doubt that distracted drivers will hear you.

Don't press the horn button in the garage, it hurts! At 139dB it can be heard for almost 3 city blocks! YEEEEOWWWW! Our warehouse manager affectionately calls these horns "People Deafeners". When we first tested the horn outside of our facility, everyone in the warehouse (as well as two of our neighbors) came outside to see what was going on. These horns are really freakin' LOUD!

Perceived volume doubles for every 3 points you go up in the decibel scale. At 139dB, the Stebel air horn is 800% louder than the more expensive 130dB FIAMM Freeway Blaster.

Includes a single 8mm mounting bolt with nut and a relay for providing a direct, high current attachment to the motorcycle's battery. No wires, fuses, or mounting brackets are included.

Specifications:

- Sound Output: 139 dB
- Current Draw: 18 Amp
- Dimensions: 5.9" (150mm) x 4.4" (112mm) x 3.7" (95 mm)
- Reaction time: less than 90 milliseconds

Starting At
\$55⁹⁹
11135



Plug-N-Play Wiring Harness for Stebel Nautilus Air Horn

Our pre-assembled wiring harness makes horn installation fast and easy! No stripping, splicing, cutting, crimping, or trips to the hardware store required! Just clip one lead to your original horn trigger wire, one lead to battery ground, one fused lead to battery positive, one high current lead to the Stebel Horn, and plug the harness into the Stebel's included relay. Includes one 30-amp ATC fuse and assembly instructions.



TT-0002:
\$29.99

Universal Horn Mounting Brackets

Our heavy duty accessory mounts come in many shapes and sizes!

These mounting brackets can also be used to mount other small items (such as auxiliary headlights) on your bike. All mounts have a 3/8" (10mm) diameter mounting hole.



Straight & L-brackets



Want to know how to mount the Stebel horn on your bike? SCAN HERE and learn how.

Part No.	Shape	Size
TWT-00-013-003	Straight	3" (2" center-to-center)
TWT-00-013-004	Straight	4" (3" center-to-center)
TWT-00-013-006	Straight	6" (5" center-to-center)
TWT-00-013-001	L-bracket	0.6" x 2.55" center-to-bend

Bike-specific Horn Mounting Brackets

Bike	Part No.	Shape	Size
Kawasaki KLR 650E, 08' & later	TWT.HMT.08.004.100	L-bracket	N/A
Suzuki V-Strom DL650, DL1000	HMT.005.821.10000	Kit	17mm - 19mm

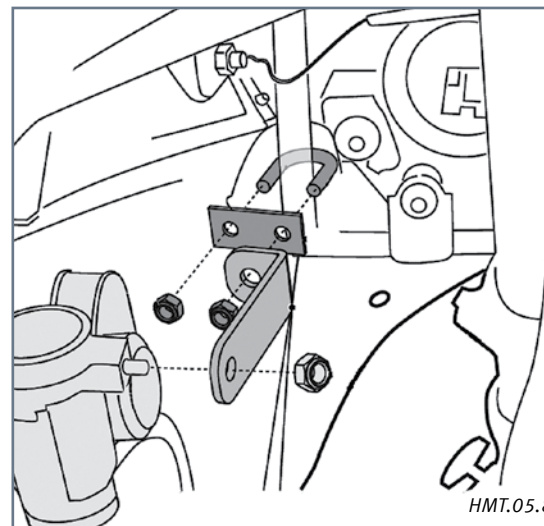

Designed to fit the left upright of the tubular fairing stay on the Suzuki DL650 & DL1000. The fairing does not need to be removed to mount this bracket. This horn mount can be "re-purposed" to fit any round bar between 17mm - 19mm.

HMT.05.821.10000: **\$17.50**



Gerbing's Microwire® technology is thinner, lighter, stronger and more durable than copper wiring. And it heats up in just 10% of the time!

Gerbing's Microwire® technology was developed in response to a Department of Defense contract for heated clothing to be used by Special Ops Forces. The wire used consists of hundreds of microscopic stainless steel strands that are about 1/4 the thickness of a human hair and wrapped in a thin Teflon coating. These wires are flexible, yet exceptionally durable. This results in a rugged garment that heats instantly.

Electrically-heated jacket liners, gloves and socks plug into a Gerbing temperature controller that is hooked directly to your motorcycle's battery. Stay warm on chilly winter nights with this marvel of modern motorcycling!

All Gerbing's heated clothing has a lifetime warranty on heating elements! Gerbing's garments are capable of maintaining a surface temperature of 135°F (+/- 5°F) at 32°F.

Microwire® Heated Jacket Liner

Extend your riding season!



GHC.JKLN: **\$199.95**

Microwire® Socks

The ultimate comfort for your feet.



GHC.SKLN: **\$89.95**

Microwire® Gloves Liners

Warm hands inside your existing non-insulated riding gloves.

Combine these Glove Liners with Macna waterproof gloves for maximum comfort and versatility. Your hands will remain dry, warm, and protected. See page 79 for Macna gloves.



GHC.GLLN: **\$79.95**

T5 Microwire® Gloves

Designed for the serious rider.



GHC.T5: **\$169.95**

Gloves can be operated while connected to Gerbing's Jacket Liner, or directly connected to the bike using the supplied Y-harness.

How does Gerbing's heated clothing work?



Gerbing's Portable Temp Controllers

- The single controller provides one temperature setting for all garments .
- The dual controller provides two separate controls for two different garments, such as for gloves and jacket liner, for the same person.
- Wires safe for all weather conditions.
- Velcro® attachment or optional belt clip cases.

GHC.TCLCD (dual)
GHC.TCLCS (single)



Baryl™ Rack Cable Mount



The Baryl™ Rack universal mounting bracket is useful for mounting your Gerbing power lead. The cable mount is designed to conform to a variety of surfaces and shapes; from round handle bars to flat body panels and everything in between. Securing your power lead with this mount allows no-fuss one-handed plug-in of your Gerbing controller. The cable saddle rotates on the base with detents every 15° to allow for optimum cable angles. Made of UV resistant Nylon.

3BR.150.0026.01: **\$12.95**

For mini-Euro socket or flush-mount wiring options, visit TwistedThrottle.com!



Oxford HotHands Heated Overgrips

- Easy-to-attach in winter and easy-to-remove on warmer days, Oxford HotHands make frozen hands a thing of the past.
- Heated grip covers attach with Velcro.
- Connects directly to battery.
- Switch with LED warning light included.
- Very low battery drain.
- 2 year warranty.

OXF.OF694: **\$54.95**



Oxford Heated Grips

Designed for 7/8" diameter handlebars with 4.75" to 4.9" open-ended grips, these are the ultimate heated grips, capable of maintaining up to 131° F (55° C).

Waterproof controller features:

- 5 power settings (100%, 75%, 40%, 30%, off).
- LED indicates current power setting.
- Auto-off when bike is turned off to prevent accidental battery drainage.
- Includes bracket for mounting controller on left-side handlebar control mount bolts (pre-drilled for two 6mm mounting screws spaced 31mm-35mm apart on center).
- Control size: 56mm (2.2") wide x 54mm (2.1") tall x 20mm (0.8") thick.
- Sport and Touring Controller features 5 settings.
- Cruiser Controller features a rotating control knob.

Includes high temperature epoxy and a fused, pre-terminated wiring harness with two 1.4" (6mm) ring terminals for connecting to a 12-volt battery.



7/8" Sport Grip Pattern
OXF.26.0696: **\$79.95**



7/8" Touring Grip Pattern
OXF.26.0695: **\$79.95**



1" Cruiser Grip Pattern
OXF.OF697: **\$79.99**

Oxford Handlebar Muffs

- These hand covers mount to your handlebars to keep your hands warm and dry even in the coldest riding weather.
- Pre-formed opening for ease of access to controls.
- Total weather protection: waterproof heavy duty 1500 denier polyester outer shell with Thermacel insulation for total warmth.
- High visibility 3M reflective piping for increased visibility to other road users.
- Does not interfere with operation of your controls.
- Includes a pocket for Oxford HotHands (sold separately) for the ultimate heated muff.

OXF.OF82: **\$49.99**



7/8" Sport & Touring Grip Controller



1" Cruiser Grip Controller



Scan here to see a video about Macna features.

Macna Jackets, Pants, and Gloves

Macna jackets, pants, and gloves are made to withstand the demands of serious motorcycle riders. Macna is known for their innovative features, attention to detail, excellent fit, superior comfort, stellar protection, and safety features that stand out from the crowd.

Build Quality

Innovative use of high-tech materials sets Macna garments apart from the crowd:

- Less bulk compared to other brands.
- Sensible zipper locations that are easy to use.
- Smart construction that ensures durability.

Materials used:

- **C-touch** is a Polyamide 500d material that has a medium abrasion resistance with a cotton look and feel.
- **R-tech** is a Polyamide 600d with medium-high abrasion resistance.
- **Durylon** is a Polyamide with Polyester material with high abrasion resistance.
- **Dynax** is a Polyamide 420d with high abrasion resistance.

Comfort

Macna jackets features a 3-layer liner system with an easy to install, independently detachable waterproof, and breathable membrane and thermal liner. Macna pants have a similar detachable membrane and thermal liner system.

Inner liners connect to the outer shell without snaps or dangling straps. This creates a smooth sleeve entrance so you can wear the gloves inside the sleeve to prevent water from running into the gloves.

Ventilation

Ample ventilation is a key component of well-built riding gear. Macna pants feature thigh vents and the jackets feature arm and chest vents.

Protection

You'll find CE-approved shoulder and elbow protection in all Macna jackets, and CE-approved knee protection in Macna pants. CE armor upgrades are available for most jackets to replace the standard back and hip foam protectors (see page 75) with CE Level 2 armor.

Visibility

Macna jackets feature laminated reflective material to illuminate the front, back, and sides of the jacket. For extra conspicuity, all jackets are ready to accept a high-viz vest that zips onto the jacket and does not interfere with access to pockets or zippers (see page 75).

Convenience

You'll really like the convenience features found on Macna jackets, including a hanger loop, adjustable arm straps, easy-to-use zipper tabs, and zippers for connecting the jackets to pants.

Please note: Macna apparel is Euro sized. Order one size larger than the typical U.S. size you wear. Call or email our gear experts if you have sizing questions.

Oasis Jacket



Lunar Jacket



Features of Macna Jackets and Pants:



Superfabric protectors are a rugged textured material that provides excellent abrasion protection and a high-tech look.



CE-approved knee, shoulder and elbow protectors provide impact protection. Knee protectors are adjustable to ensure proper position for safety and comfort.



Raintex waterproof and breathable membrane and **thermal liner** combined with the outer material create a highly protective shell.



“Easy Cuff” system uses an exterior zipper to easily connect the inner jacket and pant liners to the outer shell.



Summer Comfort Control System quickly transforms the men’s Geo and women’s Lunar jackets into a warm-weather garment. Simply remove the collar panel to reveal the high-tech **3D mesh** for maximum airflow.



Zippered Vents are located on the sleeves, chest, and in some cases, the upper back for increased airflow. Pants have vent panels in the thigh and lower leg.



Integrated heavy duty hang loop on the outside of the neck is stitched and bolted securely.



Grip Strips at the edge of pocket flaps allow easy access even when wearing heavy gloves.



Back pocket provides a convenient place to store liners. **Cinch straps** at the waist allow a custom fit.



Side Eye reflective graphics provide extra conspicuity. The Side Eye material is laminated for an integrated, smooth look and feel.

Armor Upgrade

Upgrade the standard hip and back protection with CE Level 2 approved armor.

- Visco-elastic foam with outstanding shock absorption values.
- Meets stringent European Standard EN 1621-2, Level 2.
- Anatomically shaped for maximum comfort.
- Washable.



Size Small:

40x28cm

MN.9013

Size Large:

49x33cm

MN.9012

\$44⁹⁹

Hip protector:

MN.9014

\$24⁹⁹

Vision Vest “N”

\$34⁹⁹



Vision Vests are fully integrated onto Macna jackets for maximum conspicuity. The bright neon yellow color and large reflective parts will boost your visibility day and night! The vest is fixed onto the jacket using two integrated buckles in front and a built in zipper in back.

- Attaches to the outside of all Macna jackets.
- Side Eye reflective material.
- High-viz poly 600D.

Vest Size	Men’s Jacket	Women’s Jacket
S	S-M	XS-M
M	L	L-XL
L	XL	XXL
XL	XXL+	Not used

MN.8003.707



Macna men's riding jackets feature exceptional comfort and protection. Macna jackets fit snugly and the adjustable waist and arm straps provide a custom fit. The lengthened back panel ensures complete coverage even when in riding position. The Oasis and Geo jackets are intended for all-season riding and feature detachable waterproof and thermal liners, as well as ample venting and impact protection.

Men's Oasis Jacket

Men's Oasis Jacket Features

- C-touch, Dynax materials.
- 3-layer liner system with independently detachable membrane and thermal liner.
- Side Eye visibility system, Vision Vest ready (see previous page).
- Air vents in arms and back, air panels in chest.
- CE-armor protection at shoulder and elbow.
- CE back protector ready.
- Coat hanger, arm adjustment straps, back pocket, Easycuff, 3D mesh, short pant connection zipper, and Grip strips.
- Black or Desert Gray.
- S-XXXL

Macna apparel is Euro sized. Consider ordering one size larger than your typical US size.

\$315⁰⁰

MN.3217



Men's Geo Jacket

Summer Comfort System transforms the Geo jacket into a summer jacket by simply removing the collared panel to reveal a 3D mesh panel.

Men's Geo Jacket Features

- R-tech, C-touch, and Dynax materials.
- 3-layer liner system with independently detachable membrane and thermal liner.
- Side Eye visibility system, Vision Vest ready (see previous page).
- Air Vents in arms, Summer Comfort System.
- "Powertector" CE-armor protection at shoulder and elbow.
- CE back protector ready.
- Superfabric.
- Coat hanger, arm adjustment straps, click puller, Grip strips, short pant connection zipper, Easycuff, and 3D mesh.
- Black or High-Viz.
- S-XXXL

Macna apparel is Euro sized. Consider ordering one size larger than your typical US size.

\$409⁹⁹

MN.3218





Macna women's riding jackets offer many of the same comfort and protection features found in Macna men's jackets, including detachable waterproof and thermal liners, venting, and impact protection. The Lunar and Lily jackets also feature a form-fitting cut, adjustable waist, and arm straps for a custom fit and flattering appearance.

Women's Lily Jacket

Women's Lily Jacket Features

- C-touch, and Dynax materials.
- 3-layer liner system with independently detachable membrane and thermal liner.
- Side Eye visibility system.
- Vision Vest ready (see previous page).
- Air vents in arms.
- CE-armor protection at shoulder and elbow.
- CE back protector ready.
- Arm adjustment straps.
- Short pant connection zipper.
- Black, Gray or High-Viz.
- XS-XXL

Macna apparel is Euro sized. Consider ordering one size larger than your typical US size.

\$269⁹⁹

MN.3240



Women's Lunar Jacket

Lunar Jacket Features

- Durylon, R-tech, C-touch, and Dynax materials.
- 3-layer liner system with independently detachable membrane and thermal liner.
- Side Eye visibility system, Vision Vest ready (see previous page).
- Air Vents in arms.
- Summer Comfort System.
- "Powertector" CE-armor protection at shoulder and elbow.
- CE back protector ready.
- Superfabric.
- Coat hanger, arm adjustment straps, Easycuff, Grip strips, back pocket, short pant connection zipper, and click puller.
- Black or Gray/Blue.
- XS-XXL

Macna apparel is Euro sized. Consider ordering one size larger than your typical US size.

\$379⁹⁹

MN.3242





Macna riding pants provide exceptional comfort and protection. The Alpine and Onyx 2 pants are intended for all-season riding and feature detachable waterproof and thermal liners for chilly, damp days, and air vents for warmer days.

Men's Alpine Pant

Women's Onyx 2 Pant

\$299⁹⁹

MN.2027



Full-circumference and short zippers for connecting to Macna jackets

Short zipper for connecting to Macna jackets

Belt provides a secure fit

Thigh vent

Opening the thigh vent panel on the Alpine pant reveals the 3D mesh. A magnet secures the flap in place.

Superfabric

Macna pants are waterproof all the way to the bottom of the leg.

Superfabric

Lower leg vent

The Easycuff system connects the detachable membrane with the outer shell using an external zipper for easy access and foot entry.

\$249⁹⁹

MN.2028

Men's Alpine Pant Features

- All season
- Durylon, R-tech, Dynax
- Detachable Raintex Plus membrane
- Detachable thermal liner
- Side Eye reflective material
- Air panels, Air vents
- CE-approved knee protection
- CE hip armor ready
- Superfabric
- Easycuff
- 3D mesh
- Long and short connection zippers
- Includes detachable suspenders
- Anti-slip strips
- Adjustable knee protectors
- Heatshield at bottom of leg
- Waist lock
- S-XXXL
- Black

Women's Onyx 2 pant Jacket Features

- All season
- C-touch and R-Tech
- Detachable Raintex membrane
- Detachable thermal liner
- Side Eye reflective material
- Air vents
- CE-approved knee protection
- CE hip armor ready
- Superfabric
- Easycuff
- Short connection zipper
- Adjustable knee protectors
- Heatshield at bottom of leg
- Waist lock
- XS-XXL
- Black



Gerbings Electrically Heated Glove Liners

Gerbings electrically heated glove liners, in combination with Macna waterproof gloves, provide maximum comfort and versatility. Your hands will remain dry, warm, and protected. See page 72 for Gerbings products.

GHC.GLLN: **\$79.95**



Macna Gloves

Macna gloves have many features that ensure excellent comfort and protection.



30 degree wrist strap allows enhanced comfort and free wrist movement.



The external hard knuckle protector spreads the force of impact using a cushion of air.



Curved ErgoThumb and ScreenCleaner integrated rubber squeeze.



Some Macna gloves feature the **OutDry** waterproof membrane that is laminated directly inside the outer shell to keep the glove dry and light.

Note: Macna gloves are designed so that the gauntlets are worn within the jacket sleeves. This prevents rain from pouring down the sleeve and into the glove while riding.

Men's Summer



Men's Talik

- Soft goat leather, Pittards leather
- Mesh liner
- Perforated leather venting
- Temper foam knuckle protection
- ErgoThumb
- S-XXXL

MN.6160.101



Men's Borasco

- Soft goat leather, Flock PU
- No perforation
- Bemberg liner
- Molded knuckle protection
- ErgoThumb
- 30 degree buckle
- S-XXXL

MN.6167.101

Women's Summer



Women's Lane

- Soft goat leather
- Mesh liner
- Temper foam knuckle protection
- ErgoThumb
- XS-XXL

MN.6161.101

Men's Waterproof 3-Season



Men's Vulcan

- Soft goat leather, C-touch, Stretch, Nubuck leather
- Raintex membrane with Sensigrip
- Semi-hard TPU knuckle protection and Temper foam
- 30 degree buckle
- ScreenCleaner
- ErgoThumb
- S-XXXL

MN.6164.101



Men's Vantera

- Soft goat leather, cow anilin leather, goat nubuck
- OUTDRY membrane
- Thermolite insulation, Bemberg liner
- RISC knuckle and palm protection, TPU knuckle protection
- 30 degree buckle
- ScreenCleaner
- ErgoThumb
- M-XXXL

MN.6168.101

Women's Waterproof 3-Season



Women's Cata

- Soft goat leather, C-touch, cow leather, cow nubuck
- Raintex Membrane
- Bemberg Lining
- TPU foam knuckle protection
- 30 degree buckle
- ScreenCleaner
- ErgoThumb
- XS-XXXL

MN.6166.101

Men's Waterproof Cold Weather



Men's Borax

- Soft goat leather, R-tech
- Raintex membrane
- Thermolite insulation, Isofur liner
- Semi-hard TPU knuckle protectors
- 30 degree buckle
- ScreenCleaner
- ErgoThumb
- S-XXXL

MN.6119.101



Men's Polartic

- Soft goat leather, Nubuck, Flock PU
- OUTDRY membrane
- Thermolite insulation, bemberg liner
- R.I.S.C. palm protector
- Moulded knuckle protector
- 30 degree roller buckle
- ScreenCleaner
- S-XXXL

MN.6127.101

Women's Waterproof Cold Weather



Women's Ruby

- Soft goat leather, Dynax, R-tech
- Raintex membrane
- Thermolite insulation, Isofur lining
- EVA knuckle protection
- 30 degree buckle
- ScreenCleaner
- ErgoThumb
- XS-XXL

MN.6122.101



Starting At
\$105⁹⁹

Steel Topracks are a rugged, inexpensive way to mount your hard or soft luggage, or even a RotopaX fuel tank. Steel Racks are bike-specific and are shaped to follow the lines of your bike.

Steel Racks are a permanently-mounted flat luggage rack with pre-drilled holes for mounting a variety of cargo carriers. There are also plenty of tie-down slots for strapping soft luggage to your bike. An expanding rack is available that creates a large, sturdy surface for larger luggage items (See Steel Expansion Rack below).

One of the great things about the Steel Rack is its versatility. Steel Racks accept TraX, Pelican, Coocase, or Givi topcases, as well as RotopaX auxiliary fuel tanks with additional adapter hardware. You can even mount certain tank-bags that have the Quick-Lock tankring system. Adapter hardware is sold separately.

Steel Topracks are bike-specific. See pages 156 - 227 to find a Steel Toprack that fits your motorcycle.



Topcase adapter sold separately

GPT.04.439.20001.B
KTM 690 SMC



Steel Expansion Rack

The Steel Expansion Rack turns the Steel Toprack into two racks in one. Want to carry a large duffel or dry bag? No problem, just loosen the four securing bolts and slide the wings outward. Tighten the bolts and you've got a wide and sturdy surface for the most challenging cargo.

- Can be adjusted and locked to create any width between 12" and 16.5" wide.
- Use it to attach soft luggage to a SW-MOTECH Steel Toprack.
- Easy access to an expanded Steel Toprack platform.
- Retract for a clean look.
- Secure 4 bolt installation.

GPA.00.804.10000.B: \$54.99





Additional adapter hardware allows you to mount your TraX, Pelican, Coocase, Givi topcases, or RotopaX auxiliary fuel tanks to a Steel Toprack.



Topcase Adapters for Steel Topracks	Notes	Item No.
Tankbag EVO Tankring for Steel Topracks	Used to mount flat-bottomed Bags-Connection tank bags to Steel Topracks.	TRT.00.640.13500.B
TraX Topcase Adapter		GPT.00.152.20100.B
Coocase Topcase Adapter	This adapter is included with purchase of all Coocase topcases.	
Givi / Kappa Monokey Topcase Adapter		Givi E250
Givi / Kappa Monolock Topcase Adapter	This adapter is included with purchase of all Givi Monolock topcases.	
Pelican Topcase Adapter	Also works with most other brands of flat-backed mil-spec cases.	GPA.00.800.50500.B
RotopaX Fuel Tank Adapter	Non-locking (I trust everybody) RotopaX mount. Mounting holes are pre-drilled in most Steel Toprack models.	RX.PM
RotopaX Fuel Tank Adapter	Lockable (I'm keyed and theft proof) RotopaX mount. Mounting holes are pre-drilled in most Steel Toprack models.	RX.LOX.PM
RotopaX Fuel Tank Adapter Extension	Mount multiple RotopaX tanks with this extension. Mounting holes are pre-drilled in most Steel Toprack models.	RX.EXT
Shad Topcase Adapter	Fits all Shad topcases <i>except</i> SH48, SH49, & SH50.	In Development



ALU-RACK Topracks are a sturdy and elegant solution to mounting your topcase. ALU-RACKs are made from high-strength, lightweight aluminum for durability. ALU-RACKs are bike-specific and are shaped to follow the lines of your motorcycle.

ALU-RACKs accept TraX, Pelican, Coocase, or Givi topcases using additional adapter hardware. Adapter hardware is sold separately.

A Soft Luggage Adapter is available that creates a large, sturdy surface for bulkier items (see next page and page 148).

Starting At
\$129⁹⁹

Topcase adapter sold separately

ALU-RACK Topracks are bike-specific. See pages 156-227 to find an ALU-RACK Toprack that fits your motorcycle.

BMW F800S/ST
GPT.07.306.100.B



Triumph Speed Triple 1050

GPT.11.502.100.B



Kawasaki Ninja 1000 '11 and later

GPT.08.185.10000.B



Kawasaki Versys '10 and later

GPT.08.714.10000.B



ALU-RACK Quick-Lock Adapter Plates

ALU-RACK Quick-Lock Adapter Plates are used to mount TraX, Pelican, Coocase, or Givi topcases. When not using your topcase, the adapter plate can be removed in seconds for a clean, minimalist look.

- Quarter-turn fasteners allow the adapter plate to be connected to or removed from the ALU-RACK in seconds.
- Three point mounting system keeps the plate stable and secure.
- Topcase adapter plates are specific to the brand of topcase you're attaching to the ALU-RACK.
- Soft Luggage Carrier Adapter available (see page 148).



Kawasaki Ninja 250R



Place the adapter plate onto the ALU-RACK. Using a flathead screwdriver, turn the three QUICK-LOCK fasteners 90°. Voila! The adapter plate is attached to the bike and ready to carry a topcase!



Additional adapter hardware allows you to mount your TraX, Pelican, Coocase or Givi topcases, a QUICK-LOCK tankbag, or most soft luggage to an ALU-RACK.

Soft luggage adapter on ALU-RACK



Pelican Topcase on ALU-RACK



Alu-Rack with QUICK-LOCK TraX ALU-BOX Adapter Plate



QUICK-LOCK Tankring & Bags-Connection tankbag



Coocase Topcase on ALU-RACK



QUICK-LOCK Topcase Adapters for ALU-RACKS	Notes	Part No.
Tankbag EVO Tankring for ALU-RACKS	Used to mount flat-bottomed Bags-Connection tank bags to ALU-RACKS.	TRT.00.640.20400.B
TraX Topcase Adapter Plate		GPT.00.152.400
Pelican Topcase Adapter Plate	Also works with most other brands of flat-backed mil-spec cases.	GPA.00.800.50200.B
Coocase Topcase Adapter Plates	Required to mount Coocases onto ALU-RACKS.	Small non-electric (for S28 and V37 topcases) GPT.00.152.46000.B Large non-electric (for S50 topcases) GPT.00.152.46100.B ⚡ V37 liter electric GPT.00.152.46200.B 550 liter electric GPT.00.152.46300.B
Givi / Kappa Monokey Topcase Adapter Plate		GPT.00.152.405
Givi / Kappa Monolock Topcase Adapter Plate		GPT.00.152.406
Hepco & Becker Topcase Adapter Plate	Compatible with most Hepco topcases EXCEPT the Journey TC30 and bike specific R1200RT/K1200GT topcases.	GPT.00.152.410
Shad Topcase Adapter Plate	Fits all Shad topcases <i>except</i> SH48, SH49, & SH50.	GPT.00.152.415
Krauser Topcase Adapter Plate	Requires Krauser K-WING (sold separately).	GPT.00.152.220
Universal Topcase Adapter Plate	Permanently bolt your own flat-bottomed case to this plate.	GPT.00.152.450
Soft Luggage Carrier	12" wide luggage rack with tie-down slots.	GPT.00.152.430
Adapter Plate Accessories	Notes	Part No.
Replacement QUICK-LOCK Fastener	Includes QUICK-LOCK and retention washer.	CAM.00.GPT
Quick-Disconnect Wiring Kit	For use with GPT.00.152.405 & GPT.00.152.406 adapter plates and Givi luggage with integrated brake lights.	TT-00001
Rackpack	Soft luggage bag specifically for use with Soft Luggage Carrier (see page 143).	BC.HTA.00.042.1010

QUICK-LOCK EVO Sidecarriers for Sidecases



QUICK-LOCK EVO Sidecarriers are used to mount Aero, TraX, Pelican, Hepco & Becker, Shad, Krauser, or Givi sidecases (adapters sold separately). When not using your sidecases, the sidecarriers can be removed in seconds to retain the stock appearance.

Features:

- Removable, narrow luggage carrier for many types of side luggage.
- Sidecarrier attaches and detaches from the bike in seconds.
- Robust, tubular mild steel construction.
- Sidecarriers can be used to prevent soft saddlebags from getting burned on your exhaust or caught on your rear wheel.
- Optional keyed locking QUICK-LOCK fasteners are available to prevent removal of sidecarriers.
- Hard-bolt kits available for permanent, rigid and strong mounting to withstand rough off-road riding.

Starting At
\$274⁹⁹

Sidecase adapter sold separately



TraX Sidecase

QUICK-LOCK EVO Sidecarrier with TraX Adapter

EVO Sidecarriers are bike-specific - see pages 156-227 to find a sidecarrier that fits your motorcycle.

QUICK-LOCK EVO Sidecarrier



QUICK-LOCK EVO Sidecarrier with TraX ALU-BOX



Thumb-sized mounting points remain on the bike when carrier is removed



EVO Sidecarriers are narrower than most other brands of sidecarriers

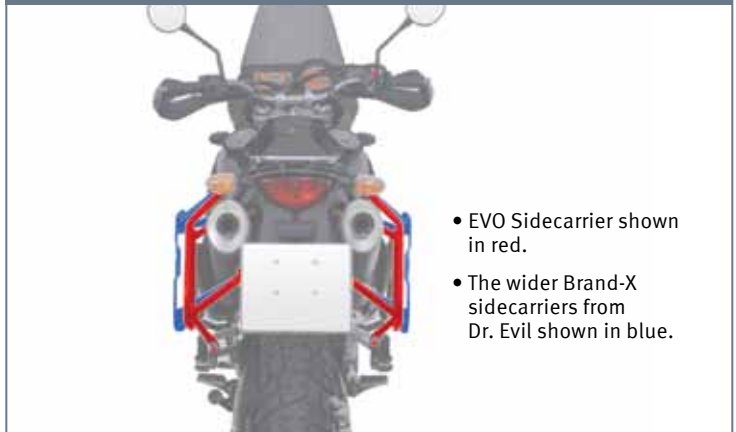

- EVO Sidecarrier shown in red.
- The wider Brand-X sidecarriers from Dr. Evil shown in blue.

Sidecase Adapters for QUICK-LOCK Sidecarriers

Sidecase Adapter Kits are necessary for attaching your luggage to the QUICK-LOCK Sidecarriers. Each adapter is specific to the brand of luggage you're attaching to your EVO Sidecarriers. Adapter kits are available for TraX, Aero, Pelican, Givi, Kappa, Hepco & Becker, Krauser and Shad sidecases. Adapters are sold separately from sidecases.

Adapters Starting At \$25.00



Kawasaki Ninja 1000

Givi / Kappa Sidecase Adapter	TraX ALU-BOX Sidecase Adapter	Pelican Sidecase Adapter
<p>KFT.00.152.205 \$26.00</p>	<p>KFT.00.152.200: \$26.00</p>	<p>KFA.00.800.50100.B: \$44.99</p>

EVO Sidecarriers are bike-specific - see pages 156-227 to find a Sidecarrier that fits your motorcycle. Sidecase Adapter is sold separately from EVO Sidecarrier.

Sidecase Adapters for Sidecarriers	Notes	Original Sidecarrier Adapter No.	EVO Carrier Adapter No.
TraX ALU-BOX Adapter	Sold in pairs	KFT.00.152.100	KFT.00.152.200
Pelican Adapter	Sold in pairs. For use with Pelican Storm cases. Also fits other flat-backed mil-spec cases. (see page 105)	KFA.00.800.50100.B	KFA.00.800.50100.B
Givi / Kappa Monokey Adapter	Pairs. Older cases may additionally require KFT.00.152.150.	KFT.00.152.105	KFT.00.152.205
Hepco & Becker Plastic Case Adapter	Sold in pairs. For Journey, Junior, and Gobi cases.	KFT.00.152.110	KFT.00.152.210
Hepco & Becker Alu Case Adapter	Sold in pairs. For Alu-Standard and Alu-Exclusive cases.	KFT.00.152.111	N/A
Shad Adapter	Sold in pairs	KFT.00.152.115	KFT.00.152.215
Krauser Adapter	Sold in pairs. For K3, K4, K5, Alu, and Bison cases.	KFT.00.152.120	KFT.00.152.220
Aero Sidecase Adapter	Sold in pairs	KFT.00.152.22600.B	KFT.00.152.22500.B
Accessories for Adapter Plates	Notes	Part No.	Part No.
Replacement QUICK-LOCK Fastener	Includes QUICK-LOCK and retention washer.	CAM.00.KFT	CAM.00.KFT
Keyed QUICK-LOCK Locking Fastener	Sold in pairs.	QLS.00.046.10100.B	QLS.00.046.10100.B
Hard-bolt Adapter Kit	Increased security and added durability in harder terrain.	KFA.00.840.10000	KFA.00.840.10000
Cam Lock Protective Caps	Cover your Cam Locks when the sidecarriers are taken off.	KFT.00.152.30000.B	KFT.00.152.30000.B

QUICK-LOCK Sidecarriers

SW-MOTECH
BAGS-CONNECTION

QUICK-LOCK: the fastest way to remove luggage racks from your bike.

Use a coin to turn a standard QUICK-LOCK fastener



Standard QUICK-LOCKS

- Attach and detach an EVO Sidecarrier from your bike in seconds with a 1/4 turn of each fastener.
- QUICK-LOCK fasteners can be turned using a coin (as shown in the photo to the left) or a flathead screwdriver.
- Standard QUICK-LOCKS are included with purchase of all EVO Sidecarriers.



SW-MOTECH is the originator of the QUICK-LOCK system

Keyed lockable QUICK-LOCKS add security without sacrificing convenience

EVO Sidecarrier with Keyed Locking QUICK-LOCK



- Replacing one standard QUICK-LOCK in each EVO Sidecarrier with a keyed locking QUICK-LOCK prevents unwanted removal of your sidecarriers.



QLS.00.046.10100.B: **\$49.99/pair**

Lock your EVO Sidecarrier to the motorcycle



Bottle Mount & Fuel Bottle



Add a Bottle Mount to the interior of your EVO Sidecarrier using our Sidecarrier Accessory Mounting Kit .

Basic Bottle Mount

This bottle mount bolts permanently to the outside of any flat-sided surface, including sidecases, and can be used to carry our MSR 30oz Fuel Bottle and Twisted Throttle 30 oz Water Bottle. It can hold any bottle with a height of 8" to 12" and a diameter of 2.5" to 4". Velcro straps and a top-end bungee cord are provided for added security.

Bottle mount includes hardware for attachment to a flat sidecase. Installation on an EVO Sidecarrier requires the Sidecarrier Accessory Mounting Kit (sold separately).

BMT.00.805.10000.B: **\$29.99**

See page 100 for fuel and water bottles.



Storage Tube with Flush Mount Kit

This storage tube attaches directly to the outside of any flat-sided sidecase and can be used to carry our MSR 30 oz Fuel Bottle & Twisted Throttle Water Bottle, as well as any other gear that can fit inside of it. It has an internal diameter of 3.25" and an internal height of 11.5".

DJA.67670.100: **\$14.99**



Sidecarrier Accessory Mounting Kit

This kit allows you to add our Basic Bottle Mount or Storage Tube to the inner side of your EVO Sidecarrier. Basic Bottle Mount and Storage Tube are sold separately.

MBK.00.806.10000.B: **\$24.99**

QUICK-LOCK Contour Carrier for Givi V35 PLX Sidecases

SW-MOTECH
BAGS-CONNECTION

Starting At
\$284.99

ORIGINAL
QUICK-LOCK
SINCE 1999

QUICK-LOCK Contour Carrier Features

- For use *only* with Givi V35 PLX and Kappa K33N K-ROAD sidecases.
- Contoured shape to fit the profile of your motorcycle for increased volume in a streamlined profile.
- Attaches and detaches from the bike in seconds.
- Givi V35 sidecases, when used with QUICK-LOCK Contour Carriers, provide the narrowest aftermarket hard luggage solution available.
- Constructed of tubular steel.
- No sidecase adapter necessary.
- Optional keyed lockable QUICK-LOCK fasteners to prevent removal of Contour Carriers. **QLS.00.046.10100.B**
- Optional hard-bolt kit to increase security and durability on rougher road surfaces. **KFA.00.840.10000.S**



Suzuki GSF1250 Bandit

See page 113 for information on Givi V35 cases.

Contour Carriers are bike-specific - see pages 156-227 to find a Contour Carrier that fits your motorcycle.

QUICK-LOCK Contour Carrier



Shown with Givi V35 sidecase attached



Mounting Points for QUICK-LOCK Sidecarriers



Narrow Bike Profile





\$315⁹⁹

Mounting hardware included

A Saddlebag System for Sport Bikes

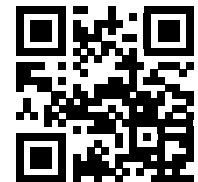

Scan this QR code to see a video about the Blaze Saddlebag System.

Support Arm Holders bolt on to passenger footpeg mounts



Tired of burnt straps, cooked saddlebags, and tire friction holes in your saddlebags? Bags-Connection Blaze Sport Saddlebags are the Solution!

The Blaze Sport Saddlebag System features an aerodynamically-shaped saddlebag that fits many modern sport bikes. Blaze Sport Saddlebags are constructed of 1680 Ballistic Nylon. Each has a volume of 14 liters (21 liters when expanded).

What's really unique about the Blaze Sport Saddlebags are the support arms. These quick-attach/detach arms support the saddlebags so they don't move. No more worrying about whether your sagging saddlebags are touching your hot exhaust or are about to get caught in your tire.

When you're done riding for the day, the saddlebags and support arms can be removed in less than a minute, returning your sportbike to its original look. No funky-looking luggage carriers! QUICK-LOCK Support Arm Holders bolt on to your passenger footpeg mounts using included hardware.

Support Arms snap into Holders in seconds



Each Sport Saddlebag Kit Includes:

- Saddlebags (pair)
- Waterproof liner bags (pair)
- Bike-Specific Support Arm Mounts (pair)
- Bike-Specific Support Arms (pair)



Bike-specific Sport Saddlebag kits are listed on the next page. Kits for more models are in development.

Support Arms prevent movement of Saddlebags



Each Sport Saddlebag expands by 2.75", providing a volume of 14 to 21 liters per bag



How to attach Blaze Sport Saddlebags to your bike:

STEP 1



Insert the Support Arms into the Support Arm Holders. **CLICK.**

STEP 2



Slide the receiving sleeve of the Saddlebag onto the Support Arm.

STEP 3



Secure the Velcro flaps over the passenger seat.

STEP 4



Connect the safety clip at the front end of each bag to the passenger footpeg mount. Now, you're ready to ride!

BMW	Year	Part No.
S1000RR	'10 - '12	HTA.07.740.10000.B
Honda		
Year	Part No.	
CBF600S	'08 - '11	HTA.01.740.10300.B
CBR600RR	'07 - '12	HTA.01.740.10000.B
CB1000R	'08 - '12	HTA.01.740.10100.B
CBF1000	'06 - '12	HTA.01.740.10200.B
CBR1000RR	'08-'12	HTA.01.740.10400.B
Kawasaki		
Year	Part No.	
ZX6R Ninja	'08 - '11	HTA.08.740.10100.B
ER6N & Ninja 650R	'09 - '11	HTA.08.740.10400.B
Z1000	'10 - '12	HTA.08.740.10200.B
ZX10R Ninja	'08 - '12	HTA.08.740.10000.B
Suzuki		
Year	Part No.	
GSX-R600	'08 - '11	HTA.05.740.10200.B
GSF650 Bandit	'09 - '11	HTA.05.740.10100.B
GSX-R1000	'09 - '11	HTA.05.740.10000.B
GSF1250 Bandit	'07 - '11	HTA.05.740.10100.B
Triumph		
Year	Part No.	
Sprint GT 1050	'10-'11	HTA.11.740.10000.B
Yamaha		
Year	Part No.	
YZF-R6	'08 - '11	HTA.06.740.10400.B
FZ6 S2	'07 - '11	HTA.06.740.10200.B
FZ8	'10 - '11	HTA.06.740.10300.B
FZ1	'06 - '12	HTA.06.740.10300.B
YZF-R1	'09 - '12	HTA.06.740.10000.B

Mounting hardware is designed to provide a safe position for the Blaze Sport Saddlebags on bikes with the original factory exhaust.





Aero Sidecase System

A Truly Unique Sidecase Design



BC.HTA.00.675.1000

\$425⁰⁰

Sidecarrier and adapter sold separately



Scan this QR code to see a video about the Aero Sidecase System.



Aero Sidecases are a new and innovative, rigid saddlebag with the look of a soft saddlebag, but with the benefits of hard sidecases. The 31-liter Aero bags are constructed with a rigid 2.5 mm thick ABS plastic shell that is covered by a Nylon laminate. The surface looks like Ballistic Nylon soft luggage, but the case has the strength and rigidity of hard luggage while remaining lightweight. Aero bags are mounted using the required QUICK-LOCK EVO Sidecarriers and AERO sidecase adapters (see page 85). Integrated locks prevent the theft of the bags.

Includes:

- Sidecases (pair)
- Waterproof dry bags (pair)
- Locking sidecarrier adapters and keys (2)
- Zipper locks (2)

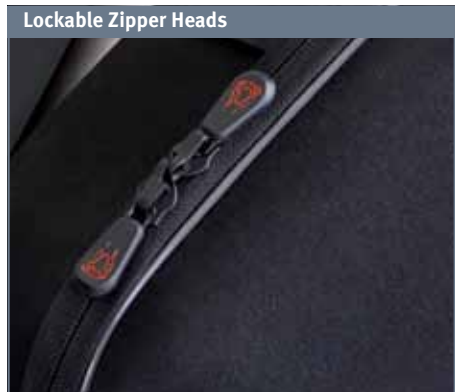

Each AERO sidecase comes with its own Bags-Connection Dry bag!

Waterproof welded tarpaulin liner bags fit perfectly into Aero sidecases to keep your stuff nice and dry. Simply wrap and connect buckles to close.



How to attach AERO Sidecases to your bike:

Aero sidecases attach to your bike using the Aero Adapter for the EVO Sidecarrier.

Aero Adapter
\$26.00
 per pair

STEP 1 Install EVO Sidecarrier mounting points (sold with sidecarrier)



STEP 2 Attach EVO Sidecarriers with Aero adapters (sold separately)



STEP 3 Slide on your Aero sidecases



STEP 4 Go ride!



Optional AERO Laptop Bag

The Aero waterproof laptop carrying bag accommodates widescreen laptops with up to 17" diagonal screens. Maximum laptop dimensions: 15.5" x 11.5" x 1.75"

Bag is also great for storing books and cookie recipes.



BC.HTA.00.675.1010 **\$34.99** each



Integrated elastic straps hold your laptop securely in place, while the included rain liner protects the laptop from the elements.

EVO Sidecarriers (sold separately) are bike-specific - see pages 156-227 to find a sidecarrier that fits your motorcycle.



Starting At
\$364.99
 Each

Carriers and adapters sold separately

TraX EVO ALU-BOX: the ultimate in durable, dependable luggage.

- Compatible with QUICK-LOCK EVO Sidecarrier, QUICK-LOCK Sidecarrier, ALU-RACK, Steel Toprack, and most tubular top racks.
- Secure, stable construction.
- 1.5mm thick aluminum plate.
- Durable stainless steel mounting hardware.
- Sidecases include 4 tie-down points. Topcase tie-downs sold separately.
- Black cases have a powdercoated interior to protect your belongings from getting smudged with aluminum oxide.
- Sheet metal construction with no-pierce, super-strong, rivet technology (the same technology that holds Audi TT frames together) for superior strength and water resistance.
- Hinges function as lid-stays.
- Strong polyamide composite corners.
- Includes dry bag liner bags.

45 Liter Sidecases



\$379.99

Left: ALK.EVO.45LD
 Right: ALK.EVO.45RD



\$404.99

Left: ALK.EVO.45LD
 Right: ALK.EVO.45RD

37 Liter Sidecases



\$364.99

Left: ALK.EVO.37LD
 Right: ALK.EVO.37RD



\$394.99

Left: ALK.EVO.37LD
 Right: ALK.EVO.37RD

38 Liter Topcases



\$379.99

ALK.EVO.38TD



\$404.99

ALK.EVO.38TD



Full TraX EVO ALU-BOX setup in Black



Full TraX EVO ALU-BOX setup in Silver Aluminum

A FREE dry bag liner bag is included with every TraX ALU-BOX!

Dry bag Liner Bags are constructed of welded PVC with an integrated carry handle.



Secure tie-down points



Durable hinges



Mounting plate



TraX Backrest

Keep your pillion partner comfortable with the TraX passenger backrest. Made of EPS foam, this backrest attaches to the 38L TraX and TraX EVO ALU-BOXES.

All mounting hardware and a fitting template is included to mount the backrest to the either the original TraX or TraX EVO topcases.

ALK.00.165.30000.B: **\$49.99**



Carrying Handles for Sidecases



Attaches to lid tie-down points and is available for all TraX cases.

BCK.ALK.00.165.116: **\$27.50**

TraX Strap-on Expansion Bag

Expands from 8 to 14 liters and attaches to the lid of 37-liter & 45-liter TraX sidecases or BMW OEM sidecases.

17" long x 8.5" wide x 5"-7" tall

BCK.ALK.00.165.117: **\$89.99**

Compressed to 8 liters.



Expanded to 14 liters.

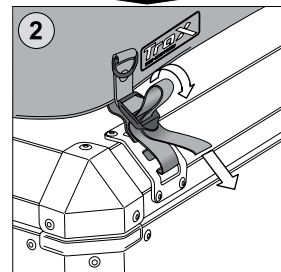
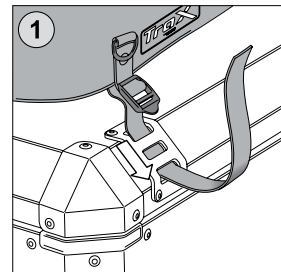

Corner Repair Kit

Have a mishap? This kit helps you repair bottom corners of the TraX ALU-BOX.

ALK.00.165.30200.B **\$29.99**



TraX Lock Sets

TraX boxes do not come with lock cylinders. Instead, matched lock cylinder and key sets are sold separately for 1 topcase, 2 sidecases or 3 cases (1 topcase and 2 sidecases).



1 Lock set: ALK.00.165.16501 **\$14.00**

2 Lock sets: ALK.00.165.16401 **\$20.00**

3 Lock sets: ALK.00.165.16301 **\$25.00**





BMW R1200GS Adventure

Item	Notes	Part No.
Dry bag Liner for 45-liter TraX ALU-BOX	Tarpaulin, Black, Waterproof.	BCK.ALK.00.165.10000.B
Dry bag Liner for 37-liter TraX ALU-BOX	Tarpaulin, Black, Waterproof.	BCK.ALK.00.165.11000.B
Dry bag Liner for TraX ALU-BOX Topcase	Tarpaulin, Black, Waterproof.	BCK.ALK.00.165.15000.B
Carrying Handle for ALU-BOX cases	Use with topcase requires installation of extra tie-down points.	BCK.ALK.00.165.116
Lock Set for 3 TraX ALU-BOX cases	Comes with 6 matching locks and 2 keys.	ALK.00.165.16301
Lock Set for 2 TraX ALU-BOX Sidecases	Comes with 4 matching locks and 2 keys.	ALK.00.165.16401
Lock Set for 1 TraX ALU-BOX	Comes with 2 matching locks and 2 key.	ALK.00.165.16501
Expansion Bag	Attaches to lid of TraX ALU-BOX Sidecases. 17" long x 8.5" wide x 5"-7" tall. Includes weatherproof liner for interior. Sold individually.	BCK.ALK.00.165.117
Backrest	For TraX Topcase.	ALK.00.165.30000.B
Tie-Down Points for TraX ALU-BOX Topcase	Includes 4 tie-down points and mounting hardware.	ALK.00.165.105-4
Retroreflective Visibility Kit for TraX Topcases	See page 117. Available in silver or black.	JMH.RG-TRXTC-02
Retroreflective Visibility Kit for TraX Sidecases	See page 117. Available in silver or black.	JMH.RG-TRXSC-01
AdMoreLighting LED Kit for Topcases	See page 114. Includes running, brake light, and turn signal functions.	AML.LED.4014.T.TS
AdMoreLighting LED Kit for Sidecases	See page 114. Includes running, brake light, and turn signal functions.	AML.LED.4014.S.TS

Suzuki DL1000 V-Strom with TraX Cases



TraX EVO ALU-BOXES attach to QUICK-LOCK EVO Sidecarriers, ALU-RACK Topracks and most tubular top racks.



TraX ALU-BOX	Notes	Part No.
TraX 45-liter EVO ALU-BOX, black, left	Includes Dry bag liner bag. 19.3" x 11" x 14.6". Powdercoated.	ALK.EVO.45LD
TraX 45-liter EVO ALU-BOX, black, right	Includes Dry bag liner bag. 19.3" x 11" x 14.6". Powdercoated.	ALK.EVO.45RD
TraX 45-liter EVO ALU-BOX, aluminum with black lid, left	Includes Dry bag liner bag. 19.3" x 11" x 14.6"	ALK.EVO.45LD
TraX 45-liter EVO ALU-BOX, aluminum with black lid, right	Includes Dry bag liner bag. 19.3" x 11" x 14.6"	ALK.EVO.45RD
TraX 37-liter EVO ALU-BOX, black, left	Includes Dry bag liner bag. 19.3" x 9.1" x 14.6". Powdercoated.	ALK.EVO.37LD
TraX 37-liter EVO ALU-BOX, black, right	Includes Dry bag liner bag. 19.3" x 9.1" x 14.6". Powdercoated.	ALK.EVO.37RD
TraX 37-liter EVO ALU-BOX, aluminum with black lid, left	Includes Dry bag liner bag. 19.3" x 9.1" x 14.6"	ALK.EVO.37LD
TraX 37-liter EVO ALU-BOX, aluminum with black lid, right	Includes Dry bag liner bag. 19.3" x 9.1" x 14.6"	ALK.EVO.37RD
TraX 38-liter EVO ALU-BOX Topcase, black	Includes Dry bag liner bag. 16.1" x 13.4" x 13". Powdercoated.	ALK.EVO.38TD
TraX 38-liter EVO ALU-BOX Topcase, aluminum with black lid	Includes Dry bag liner bag. 16.1" x 13.4" x 13"	ALK.EVO.38TD
TraX Mounting Hardware	Notes	Part No.
TraX Universal Topcase Adapter	For mounting TraX Topcases to flat tubular luggage racks. Powdercoated black.	GPB.00.152.165
TraX Topcase Adapter for SW-MOTECH ALU-RACKS	SW-MOTECH ALU-RACKS sold separately (see page 82-83).	GPT.00.152.400
TraX Topcase Adapter for Givi Topracks	Givi top racks sold separately. Fits most Givi SR and FZ top racks.	GPT.00.152.159
TraX Sidecase Adapter for QUICK-LOCK Sidecarriers	SW-MOTECH QUICK-LOCK Sidecarrier sold separately (see page 85).	KFT.00.152.100
TraX Sidecase Adapter for EVO Sidecarriers	SW-MOTECH EVO Sidecarrier sold separately (see page 85).	KFT.00.152.200



TraX cases fit on many types of sidecarriers.

TraX Sidecase Adapter Kit for mounting TraX sidecases on other brands of sidecarriers (Givi sidecarrier shown here).



TraX 37L ALU-Box

TraX adapter on BMW R1200GS Adventure

GS Adventure Adapter Kit



KFT.00.152.10800.S: **\$153.99**
Sheet metal loop included.

- Adapter kit allows TraX 37-liter and TraX 45-liter ALU-Boxes to be attached to BMW, Givi, and Hepco & Becker sidecarriers.
- One-time installation of the kit allows fast, lockable attachment of TraX sidecases as often you like.
- Givi and Hepco & Becker adapter kits are powdercoated black.
- BMW R1200GS Adventure adapter kit is powdercoated silver.
- Sold in pairs.

TraX on Hepco-Becker sidecarriers

Hepco-Becker Adapter Kit



KFT.00.152.10600.B: **\$109.99**

Item	Part No.
TraX Sidecase Adapter Kit for Hepco & Becker sidecarriers	KFT.00.152.10600.B
TraX Sidecase Adapter Kit for Givi sidecarriers	KFT.00.152.10700.B
TraX Sidecase Adapter Kit for BMW R1200GS Adventure	KFT.00.152.10800.S

TraX on Givi sidecarriers

Givi Adapter Kit



KFT.00.152.10700.B: **\$109.99**



TraX shown here on GIVI sidecarriers.

TraX Universal Adapter Plate

The TraX Universal adapter plate is used for mounting a TraX Topcase directly to flat original and aftermarket rear luggage racks.

\$74⁹⁹

GPB.00.152.165



Shown on
BMW R1200GS Adventure

TraX Topcase about to be mounted on Universal Adapter Plate.



- Permanently install the TraX Universal Adapter Plate for easy attachment and detachment of the TraX Topcase.
- The plate provides a flat, stable surface that can be used as a solid toprack when the topcase is not needed.
- Constructed of steel, powdercoated black.
- Includes mounting hardware and instructions for attaching to generic tubular-steel flat rear luggage racks.

NOTE: This plate cannot be used if your bike does not already have an existing tubular-steel flat rear luggage rack.

TraX Topcase mounted on Universal Adapter Plate



Underside of Mounted TraX Universal Adapter Plate



Schematic of TraX Universal Adapter Plate

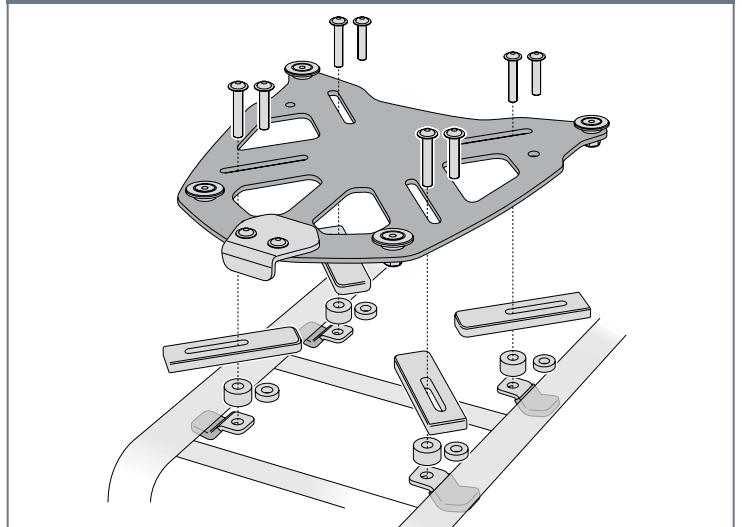

TraX Stowable Camp Table

ALK.00.165.30500: **\$119.99**

Our aluminum camp table stows easily inside your TraX sidecases and provides a stable 16.5" x 27" platform for important campsite activities. We dig it.

Folded dimensions: 16.5" long x 7.5" wide x 1.25" thick

The Camp Table folds in half for storage and fits easily inside the lid of a TraX EVO sidecase using the included Stow Bar.



Camp Table Legs

ALK.00.165.30600: **\$65.50**

Need more ways to use your trusty camp table?

This set of aluminum table legs attaches to your Camp Table with included thumbscrews. Use the four fixed-length legs to create a stand-alone table.

Alternatively, you can convert the four fixed-length legs into two adjustable-length legs (13" - 16.75" long). These two adjustable legs can support the Camp Table when attached to only one TraX box.

The set shrinks down to 13" long x 1.5" wide x 1.5" deep for easy storage.



Create a 20" x 16.5" table using your Camp Table and one TraX box.

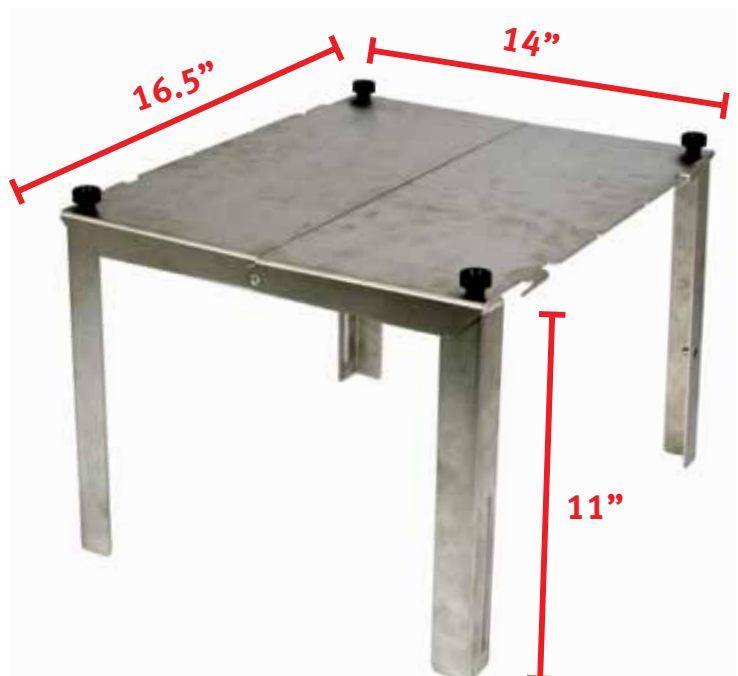

Looking for extra storage?



Basic Bottle Mount with MSR 30oz Fuel Bottle

Basic Bottle Mount

This bottle mount bolts permanently to the outside of any flat-sided surface, including sidecases, and can be used to carry our MSR 30oz Fuel Bottle and Twisted Throttle 30 oz Water Bottle. It can hold any bottle with a height of 8" to 12" and a diameter of 2.5" to 4". Velcro straps and a top-end bungee cord are provided for added security.

Bottle mount includes hardware for attachment to flat surfaces, including sidecases. Installation onto an QUICK-LOCK EVO Sidecarrier requires the Sidecarrier Accessory Mounting Kit (sold separately, see page 86).

BMT.00.805.10000.B: **\$29.95**

MSR 30oz (887ml) Fuel Bottle

Air-tight seal allows fuel to be stored longer by preventing air from entering and degrading fuel. Made from a single-piece of impact-extruded aluminum to prevent leaks and cracks. Bolstered shoulder and base to resist bulging when pressurized. Diameter 3.15"

CCD.11832: **\$19.95**



Twisted Throttle 32oz (946ml) Water Bottle

Take us with you on the go with this swanky Twisted Throttle branded water bottle. Measuring 10.6" tall with a diameter of 3.15", this aluminum water bottle holds 32 oz and is completely BPA free.

GWB-39376: **\$9.95**

Storage Tube with Flush Mount Kit

This storage tube attaches directly to the outside of any flat-sided sidecase and can be used to carry our MSR 30 oz Fuel Bottle and Twisted Throttle Water Bottle, as well as any other gear that can fit inside of it. It has an internal diameter of 3.25" and an internal height of 11.5". The storage tube mounting kit includes the proper size drill bit, hex head screws, sealing washers, and large exterior washers.



Storage Tube with MSR 30oz Fuel Bottle

DJA.67670.100: **\$14.99**

Sidecarrier Accessory Mounting Kit

If you would like to attach the Basic Bottle Mount or Storage Tube to an SW-MOTECH EVO Sidecarrier, you must order the optional mounting kit shown below.



MBK.00.806.10000.B: **\$24.99**

Dimensions: 3.75"
2.6mm thick steel
Inner hole diameter is 9.8mm

Bottle Mount with MSR Fuel Bottle on Pelican Case



Storage Tube mounted on Pelican Case



Looking for a more discreet way of mounting extra storage? Check out page 86 for the Sidecarrier Accessory Mounting Kit!

QUICK-LOCK Baseplate:

This base plate bolts permanently to the outside of any flat-sided surface, including TraX and Pelican sidecases. Any of the bottle holders will slide into the base plate and lock in place. To release a holder from the base plate, just press the release switch. Base plate kit includes drill bit, bolts, nuts, and washers for easy installation.

ALK.00.165.30900.S: **\$49.99**

QUICK-LOCK Baseplate on TraX sidecase



QUICK-LOCK Fuel Canister with Holder:

Kit includes one 2-liter black plastic fuel canister and holder with straps. Approximate bottle dimensions: 8.25"H x 5.5" W x 3.3" D.

ALK.00.165.31100.B: **\$74.99**



QUICK-LOCK fuel bottle holder



2 liter fuel bottle



Single Bottle Holder
ALK.TT.01

Dual Bottle Holder
ALK.TT.02

QUICK-LOCK Aluminum Bottle Holders

The single and dual bottle holders can be used to carry our MSR 30 oz Fuel Bottle, Twisted Throttle 32 oz Water Bottle, or any other bottle with a height of 8" to 12" and a diameter of 2.5" to 4". Includes bottle mounting straps.

Single: ALK.TT.01 **\$52.50**

Double: ALK.TT.02: **\$64.99**



Quickly release the bottle holder with a swipe of the thumb



ROTO X PAX™

RotopaX Fuel and Water Cells

Leak-proof RotopaX 1-gallon fuel and water packs allow you to ride longer with extended fuel capacity!
Designed as a modular system to stack and lock to optional pack mounts (see next page).



Fuel Cell

- 1-gallon fuel capacity.
- 9.5" x 13 1/4" x 3"
- New and improved spout!
Spouts turn around and store inside of the fuel packs.
- Pack Mounts sold separately.

\$49⁹⁵

RX.1G



Water Cell

- 1-gallon water capacity.
- 9.5" x 13 1/4" x 3"
- Pack Mounts sold separately.

\$29⁹⁵

RX.1W



RotopaX Fuel & Water Cells
on Dakar rally racer Patrick Trahan's
custom Twisted Throttle Honda XR650L



Twist & Lock Mounting Hardware

Pack Mount

The quickest, strongest way to mount your RotopaX.

- Anodized aluminum.
- Use with included backing plate or remove plate to attach mount directly by bolting up through the bottom or directly through the top.
- Mounting Disk included.
- Mounting hardware included.
- Bolts directly to SW-MOTECH Steel Topracks.

RX.PM: \$24.95



LOX Pack Mount

Includes a locking mechanism into the handle, preventing theft of your Fuel Pack.

- Anodized aluminum.
- Provides extreme tightening for powerful security.
- Locks fuel cells or storage packs.
- Mounting hardware included.
- Mounting Disk included.
- Bolts directly to SW-MOTECH Steel Topracks.

RX.LOX.PM: \$39.95



Pack Mount Extension

Enables two Fuel Packs to be mounted on top of each other.

Use in conjunction with pack mounts. (RX-PM, RX-LOX-PM)

RX.EXT: \$19.95



Pack Mount with Pack Mount Extension.

Backing Plate

Used in conjunction with the included Mounting Disk to provide additional support to the backside of the mounting surface.

- Powder coated steel.
- 5.5" round, 16 gauge (.063")
- Pre-drilled holes for 8mm bolts.

RX.BP: \$4.95



SW-MOTECH Steel Topracks have pre-drilled holes that accept RotopaX Pack Mounts. See page 80-81 for more information on Steel Topracks.

RotopaX Fuel Cell mounted to 38-liter TraX ALU-BOX on a Moto Guzzi Stelvio





Pelican Storm iM2600 Luggage Case for use with top and sidecarriers.

An indestructible and waterproof MILITARY-SPEC luggage case.

- Press & Pull Latches
- Double-layered, soft-grip Handle
- Vortex® Pressure Valve
- Lightweight, strong HPX® Resin
- Guaranteed for life

Exterior Dimensions: 21.2" x 16.0" x 8.3"

Interior Dimensions: 20.0" x 14.0" x 7.7"

Case Weight: Standard - 11.5 lbs / Luxury - 12 lbs



The Pelican Storm iM2600 System comes in Standard and Deluxe versions.

- **Deluxe cases** feature lid-stays, have locking lids, and are lockable to the bike. Deluxe cases are only available in complete packages to ensure that the lid locks and quick release adapter locks are keyed alike.
- **Standard cases** are not equipped with lid stays or lid locks. Lids can still be locked through lock tabs designed to accept padlocks (padlocks not included).

**Starting At
\$210⁰⁰**

Includes case and quick release adapter (each), toprack and sidecarriers sold separately.

Pelican Storm "Deluxe" with lid lock and lid stays



Buy just the case, just the quick release adapters, or the complete luggage system

Pelican Cases and Accessories		Part Number
Pelican Storm iM2600 Case	Standard iM2600 Luggage Case (lid locks and lid stays are only available in the deluxe packages).	PEL.IM2600.00000.S
Spacer Kit	Spacer kit for Suzuki DL650 V-Strom all years, Triumph Tiger 1050 '05-on (left sidecarrier).	KFA.05.00
Quick Release Pelican Adapters	Everything you need to turn <i>your</i> favorite case into quick release motorcycle luggage (cases sold separately).	Part Number
Top Case Adapter Kit (1)	Includes a quick-release adapter and a carrier lock. Choose Steel Toprack or ALU-RACK adapter. No case.	PEL.105
Side Case Adapter Kit (2)	Includes (2) quick-release adapters, (2) carrier locks, and Givi/SW-MOTECH side rack mounting hardware. No case.	PEL.205
3 Case Adapter Kit (3)	Includes three quick-release adapters, (3) carrier locks and Givi/SW-MOTECH side rack hardware. Choose Steel Toprack or ALU-RACK adapter hardware to complete the kit. No case.	PEL.305
Pelican Storm Standard Packages	Includes standard cases with all necessary quick release adapters .	Part Number
Standard Top Case Package	Includes (1) iM2600 case with a carrier lock & a quick-release adapter. Choose Steel Toprack or ALU-RACK adapters.	PEL.IM2600.100.S
Standard Side Case Package	Includes (2) iM2600 cases with (2) carrier locks and (2) quick-release adapters.	PEL.IM2600.200.S
Standard 3 Case Package	Includes (3) iM2600 cases with (3) carrier locks and (3) quick-release adapters. Choose Steel Toprack or ALU-RACK adapter hardware to complete the kit.	PEL.IM2600.300.S
Pelican Storm Deluxe Packages	Includes Deluxe cases with integrated lid locks and lid stays and all necessary quick release adapters .	Part Number
Deluxe Top Case Package	Includes one iM2600 case with a carrier lock, a case lock, lid stays, and a quick-release adapters. Choose Steel Toprack or ALU-RACK adapter hardware to complete the kit.	PEL.IM2600.110.D
Deluxe Side Case Package	Includes two iM2600 Deluxe cases with (2) carrier locks, (2) case locks, lid stays, and (2)quick-release adapters.	PEL.IM2600.200.D
Deluxe 3 Case Package	Includes three iM2600 Deluxe cases with (3) carrier locks, (3) case locks, lid stays, and (3)quick-release adapters. Choose Steel Toprack or ALU-RACK adapter hardware to complete the kit.	PEL.IM2600.300.D

*Sidecarriers and topracks sold separately.

Universal Quick Release Case Adapter

Turn your favorite mil-spec cases into quick release motorcycle luggage. Simply mount the U-shaped quick release adapter to your case and mount the rack adapter hardware to your top or side rack. **The integrated snap lock enables effortless one-handed attaching and removal of the cases.**

To attach the cases, just line up the bottom feet with the guides on the rack and snap the case into the lock catch. You will hear a snap as the case engages and locks to the rack. To remove the case just turn the key and lift up.

The Quick Release Case Adapters work on SW-MOTECH top and side racks as well as Givi PL-series and PLR-series side racks.

Starting At
\$10250

Adapter only (each). Cases, top rack, and sidecarriers sold separately.

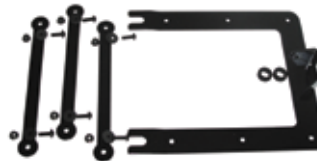

Quick-release adapter with carrier lock



Adapter dimensions:
10.5" wide by 12" tall.

BMW F800GS with the complete 3 case Pelican System



PEL.IM2600.300.S

Suzuki DRZ400SM with Pelican Topcase Kit



PEL.IM2600.100.S



Learn more about the Pelican system by watching this short video.



Pelican Side cases on a KTM 990 SMT

PEL.IM2600.200.S



Why choose Coocase Topcases?

Coocase Topcases

are full-featured, stylish cases that provide secure, waterproof storage for your precious cargo. Each base and lid is made from tough nitrogen-injected polypropylene with sturdy hinges and locking systems. Coocase topcases come with a universal mounting plate and hardware for easy installation.

Coocase topcases are available in two versions. You can choose the **Basic** topcase or you can opt for the feature-rich **Volt** edition.

Basic Topcase Features:

- Simple operation: Just push down on the lid to latch it in place. To open, push the top red button and lift the lid. Push the bottom button to release the case from the mounting plate.
- Ratcheting lid-supports prevent the lid from accidentally closing on your fingers.
- Hidden carry handle.
- Includes universal mounting plate suitable for flat rear luggage racks.
- Three-year warranty.

Additional Features included with Volt Topcases:

- Integrated LED running light and brake light.
- Remote control keyless entry with a 50 foot range. Two keys are included (one folds into the remote control).
- Soft, cushioned inner liner.
- Interior hookup port for a 12-volt cigarette socket and USB charger. Accessory Charger Kit sold separately (see page 109).



S50 Volt in Gloss black:
CC.S50.LLW.148A \$299.99



Coocase or... Robby the Robot? Coocase's ultra-bright LED brake lights are simply sinister on the road at night.

See pages 110-111 for bike-specific Coocase installation hardware.



Included is a universal mounting plate that is compatible with all flat rear luggage racks, including all SW-MOTECH Steel Topracks, SW-MOTECH ALU-RACKS, and many original rear racks. See full application chart at www.twistedthrottle.com



No complicated latch mechanism to figure out! To open the lid, just push the release button and lift. To latch the lid, push it closed.



Customize the look of your case by replacing the original lenses with red, smoke, or clear lenses (replacements sold separately).



Padded backrests are available for all topcases.
CC.BR-02 fits V37 and S50: \$39.99
CC.BR-03 fits S28: \$39.99

CooCase Basic Topcases

S28, V37, and S50 Basic Topcases

Basic Topcases are an economical choice for riders who don't need the extra features found on the top-of-the-line Volt edition (see next page). The Basic models have all of the same structural features as the Volt, including rugged lid and base construction. Basic Edition topcases are available in matte black ONLY.

Includes universal mounting plate suitable for flat rear luggage racks.

See pages 110-111 for application chart.



CooCase S28 Basic Topcase

Matte black with red lens

Dimensions: 15.3" w x 14.5" h x 11" d

Capacity: 28 liters, fits one typical medium-sized full-face helmet.

MSRP \$89.99

SALE PRICE!

\$69.99

Optional Padded Backrest
CC.BR-03 fits S28: \$39.99

* valid through April 2012



S28 Basic (matte black only)
CC.S28.B

CooCase V37 Basic Topcase

Matte black with clear lenses

Dimensions: 17" w x 12.5" h x 16" d

Capacity: 37 liters, holds one extra-large full-face helmet plus a few additional small items.

\$155.00



V37 Basic (matte black only)
CC.V37.B

Optional Padded Backrest CC.BR-03: \$39.99

CooCase S50 Basic Topcase

Matte black with clear lenses

Dimensions: 22.7" w x 12.3" h x 17.3" d

Capacity: 50 liters, holds two extra-large full-face helmets.

\$229.99



S50 Basic (matte black only)
CC.S50.B

Optional Padded Backrest CC.BR-02: \$39.99

Coccase Volt Topcases

V37 and S50 Volt topcases

Volt Topcases include all of the features of Basic Topcases plus premium features that enhance safety, convenience, and security.

Additional Features included with Volt Topcases:

- Remote control keyless entry with a 50 foot range.
- Soft cushioned inner liner.
- Alarm with custom sensitivity control.
- Integrated LED running light and brake light.
- Interior 12-volt cigarette socket and USB charger available
Accessory Charger Kit sold separately (see next page).

See pages 110-111 for application chart.



Coccase V37 Volt Topcase

Matte black with clear lenses

Gloss black with clear lenses

Silver with smoke lenses

Dimensions: 17" w x 12.5" h x 16" d

Capacity: 37 liters, holds one full-face helmet plus a few additional small items.

\$249⁰⁰

Optional Padded Backrest CC.BR-02: **\$39.99**

Coccase S50 Volt Topcase

Matte black with clear lenses

Gloss black with clear lenses

Silver with smoke lenses

Dimensions: 22.7" w x 12.3" h x 17.3" d

Capacity: 50 liters, holds two extra-large full-face helmets.

\$299⁰⁰

Optional Padded Backrest CC.BR-02: **\$39.99**



V37 Volt (matte black)
CC.V37.LLW.148AM

S50 Volt (matte black)
CC.S50.LLW.148AM



V37 Volt (gloss black)
CC.V37.LLW.148A

S50 Volt (gloss black)
CC.S50.LLW.148A



V37 Volt (gloss silver)
CC.V37.LLW.1647

S50 Volt (gloss silver)
CC.S50.LLW.1647



Coccase Volt Accessory Charger Kit

Charge Your Mobile Phone in your Coccase!

This kit provides a 12-volt cigarette socket for the inside of your Coccase **Volt Topcase** (V37 and S50).

Connect the socket to the Coccase's internal power port, and the socket's blue LED will light up to let you know it's got juice.

The kit also includes the USB charging adapters shown to the right, making it easy to charge most cell phones, mp3 players, and other small electronics from within your Coccase **Volt Topcase**.

Not available for **Basic Topcases**.

\$19⁹⁹

CC.1050101

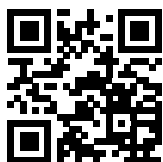

Scan here for a Coccase demonstration video!

Want your Coccase to stand out at night? See page 116 for ReflectGuard reflective sticker kits!

Coocase S50 on Honda Silverwing



Coocase V37 on BMW R1200GS Adventure



Coocase V37 on Suzuki DL650 V-Strom



Aprilia	Mounts with	Notes
Atlantic 125, 200, & 250	Contact Us	1
Atlantic 500, '02-'06	Contact Us	1
Capnord ETV1000	Contact Us	1
Mana 850	Accessory carrier	1
Scarabeo 125-200, '07-'11	Original carrier	5
Scarabeo 250, 400, 500, & 500ie, '06-'11	Contact Us	5
Sportcity 125, 200, & 250, '04-'08	Contact Us	6
Sportcity 250, '09-'11	Original carrier	6
SR50, '09-'11	Accessory carrier for SR50 R/R Factory	6
SR50 Ditech, '97-'04	Contact Us	6
BMW (all Coocase models are CANbus & ABS compatible)	Mounts with	Notes
F650CS Scarver, '02 - on	GPT.07.375.100.S	4
F650GS & F650GS/Dakar, '00-'03	Contact Us	1
F650GS & F650GS/Dakar, '04-'07	R-BMW002	6
F650GS, '08- & F800GS, '08 - on	GPT.07.558.20000.B	4
F800R, '10	GPT.07.306.100.B	4
F800S, '06-'09	GPT.07.306.100.B	4
F800ST, '06-'10	Original carrier	6
G650GS, '09-'11	R-BMW002	6
G650 Xchallenge, Xcountry, & Xmoto, '07-'11	GPT.07.613.100	4
K1200R & K1200R Sport, '05-'08 / K1300R, '09-'11	GPT.07.411.100	4
K1200S, '05-'08 / K1300S, '09-'11	GPT.07.361.100	4
K1200GT, '03-'05 / K1200RS, '00-'05	Contact Us	1
K1200GT, '06-'08 / K1300GT, '09-'11	GPT.07.644.10000.B	4
R1100GS & R1150GS	GPT.07.337.100.S	4
R1150GS Adventure	GPT.07.726.20000.S	4
R1150R & R1150R Rockster, '00-'06	GPT.07.345.100	4
R1200GS, '04-'11	GPT.07.352.20000.S	6
R1200GS Adventure, '06-'11	Original carrier	6
R1200R, '07-'11 without original top or sidecarrier	GPT.07.612.100	4
R1200R, '07-'11 with original topcarrier	R-BMW001-01	6
R1200RT, '05-'11	R-BMW001-01	6
R1200ST, '05-'07	GPT.07.550.100	4

Buell	Mounts with	Notes
XB12X Ulysses	FHG.7137G	6
Ducati	Mounts with	Notes
Hypermotard 1100 and 1100S, '08-'11	Accessory carrier 96760508B	6
Monster 696 & 1100, '08-'11	Contact Us	1
Multistrada 1200, '10-'11	GPT.22.139.10000.B	4
Multistrada (all), '03-'09	Contact Us	3
Sportclassic GT1000, '07-'11	Accessory carrier 967560AAA	6
Genuine Scooter Company	Mounts with	Notes
Buddy 50 / 125 / 150	Original carrier	6
Rattler 110	Original carrier	6
Stella 150	Original carrier	6
Harley-Davidson	Mounts with	Notes
All models	Accessory carrier	6, 7
Honda	Mounts with	Notes
Jazz (49cc scooter)	Original carrier	6
Metropolitan (49cc scooter), '09-11	Accessory carrier 08L42-GET-100	6
Ruckus (49cc scooter), '04-'11	Contact Us	6
Elite (108cc scooter)	Original carrier	6
CBR125, '04-'10	GPT.01.323.100	4
CBR125 & CBR250, '11	In development	6
PCX 125, '11	In development	6
SH150i, '09-'11	In development	6
CRF230L & CRF230M	Accessory carrier 08L42-KFB-200A	6
Reflex 250 / Jazz 250, '01-'08	Contact Us	1
599 / CB600F Hornet, '06 + Earlier	GPT.01.205.100	4
CBF600S & CBF1000	GPT.01.277.101	4
Silverwing 600	Original carrier	5
DN-01 (680cc)	Contact Us	1
NT700V Deauville	GPT.01.615.100.B	4
VT750 Shadow models (all)	Accessory carrier	6, 7
VFR800 Interceptor VTEC, '02-'11	GPT.01.208.100	4
919 / CB900 Hornet	GPT.01.131.100	4
XL1000V Varadero, '08-'11	GPT.01.625.100	4

Visit TwistedThrottle.com for Coocase fitting information if your bike isn't listed here!

Honda (continued)	Mounts with	Notes
CBF1000F, '10-'11	GPT.01.731.10000.B	4
CB1000R, '10-'11	GPT.01.462.100.B	4
CBR1100XX Blackbird (all)	GPT.01.207.100	4
VT1100 Shadow models (all)	Accessory carrier	6, 7
VFR1200F, '10-'11	GPT.01.723.10000.B	4
ST1300 (all)	GPT.01.814.20000.S	6
VTX1300 & VTX1800 (all)	Accessory carrier	6, 7
Kawasaki	Mounts with	Notes
Ninja 250R, '88-'07	GPT.08.819.10000.B	4
Ninja 250R, '08-'11	GPT.08.820.10000.B	4
Ninja 500R, '87-'11	Contact Us	1
Ninja 650R & ER6N, '06-'08	GPT.08.391.100BR01	4
Ninja 650R & ER6N, '09-'11 (requires Euro grab rails)	GPT.08.672.10000.B	4
Versys 650, '07-'09	GPT.08.391.100BR01	4
Versys 650, '10-'11	GPT.08.714.10000.B	4
KLR650A, '86-'07	GPT.08.010.100	6
KLR650E, '08-'11	GPT.08.365.20000.B	6
Z750S, '05-'07	GPT.08.335.100	4
Vulcan 900 & 800	Accessory carrier	6, 7
Concours GTR1000	Contact Us	6
Z1000, '03-'06	Contact Us	1
Z1000, '07-'09	GPT.08.385.100	4
ZRX1200R / ZRX1100	GPT.08.273.100	4
ZZR1200	GPT.08.269.100	4
ZX14 (requires Euro tail cover)	GPT.08.161.100.B	4
Concours GTR1400	GPT.08.815.20000.B	4
Vulcan 1700, 1600, & 1500	Accessory carrier	6, 7
KTM	Mounts with	Notes
LC4 690 Enduro & SMC, '07-'11	GPT.04.439.100.B	4
LC4 Adventure 640, 640 Enduro, and Duke I	GPB.04.054.100	6
Adventure 950, 950/S, 990, & 990/S	GPT.04.256.20000	4
Supermoto 950, '06-'09 & SuperEnduro 950, '07-	GPT.04.526.100	4
Supermoto 990 & SMR 990, '09-'11	GPT.04.654.10000.B	4
SMT 990, '09-'11	GPT.04.654.10000.B	4
Kymco	Mounts with	Notes
Agility50, 125, & 150, '08-'11	GPT.25.8009.30000.B	6
People 50 2T / 150 / 250	Original carrier	6
People S 50 4T / 125 / 200 / 250	Original carrier	6
Downtown 300, '09-'11	GPT.25.8014.30000.B	6
Xciting 250, 300, & 500	GPT.25.8016.30000.B	1
Moto Guzzi	Mounts with	Notes
California III, EV11, & Classic	Original carrier; backrest must be removed	6
Breva 750, '03-'09	Contact Us	1
Breva 1100, '05-'09 & Norge 1200, '06-'09	Contact Us	1
Stelvio 1200, '08-'09	Contact Us	1
Piaggio	Mounts with	Notes
Beverly BV125, BV250, BV400, & BV500, '05-'11	Contact Us	6
Beverly BV200, BV250, & BV500, '04 & Earlier	Contact Us	6
Fly 50, 125, & 150, '04-'10	Contact Us	6
MP3 250 / 400	Contact Us	1
MP3 500	Contact Us	1
X9 Evolution 500	Contact Us	1
Suzuki	Mounts with	Notes
Bandit GSF600 ('00-), GSF650, GSF1200 ('01-), & GSF1250	GPT.05.299.100	4
Boulevard S40, S50, & S83 & GZ250	Accessory carrier; must cut off sissybar	6
Boulevard C50 / VL800 Volusia, C90, C109R, M50, M109R	Accessory carrier 990A0-75066	6
Burgman AN400, '00-'06	Contact Us	1
Burgman AN400 Type S, '05-'06	Contact Us	1
Burgman AN400, '07-'11	GPT.05.8004.30000.B	6
Burgman AN650 (all years)	GPT.05.8005.30000.B	6
DR-Z400S & DR-Z400SM	Accessory carrier 46300-29820	6
DR650SE, '96 - on	Accessory carrier 46300-32811-20H or GPT.05.153.100.B	6
Gladius	GPT.05.631.10000.B	4
GS500E & GS500F, '89-'10	GPT.05.285.100	4
GSX600F Katana & GSX750F Katana, '03-'07	Contact Us	1
GSX650F & GSX1250F, '08-'11	GPT.05.299.100	4
Hayabusa GSX1300R, '07 & Earlier	GPT.05.209.100	4
Hayabusa GSX1340R, '08-'11	GPT.05.576.100	4
SV650 & SV1000, '03-'11	GPT.05.232.100	4
V-Strom DL1000 '02-'11 & DL650, '04-'11	Original carrier	4

Triumph	Mounts with	Notes
America, '02-'11	Accessory carrier A9738028	6
Bonneville & Bonneville T100, '11 & Earlier	Accessory carrier A9738191	6
Scrambler, '11 & Earlier	Accessory carrier	6
Speedmaster, '11 & Earlier	Accessory carrier A9738028	6
Speed Triple 1050, '05-'07	GPT.11.259.100	4
Sprint RS / Sprint ST 955i, '99-'04	GPT.11.291.100	4
Sprint ST 1050, '05-'11	Accessory carrier or GPT.11.527.100	4
Street Triple 675, '08-'11	GPT.11.574.10000.B	4
Thunderbird, '09-'11	Accessory carrier	6, 7
Tiger 1050 with OEM sidecases	Accessory carrier or GPT.11.527.100	4
Tiger 1050 without OEM sidecases	Accessory carrier GPT.11.619.100	4
Tiger 955	Original carrier	6
Tiger 800 & 800XC, '11	GPT.11.747.20001	4
Vespa	Mounts with	Notes
GT200, '09 & Earlier	Original carrier	6
GT60, GTS250, & GTV250	Original carrier	6
GTS300 Super, '08-'11	Contact Us	
LX50, LX150	Accessory carrier 602894M	6
LXV150	Original carrier	6
S50, S125, & S150	Accessory carrier 656105	6
Victory	Mounts with	Notes
Hammer, Kingpin, & Vegas (all years)	Accessory carrier	6, 7
Yamaha	Mounts with	Notes
C3, '07-'10	Accessory carrier ABA-3B351-00-00	6
FJR1300, '01-'05	Contact Us	1
FJR1300, '06-'11	GPT.06.813.20000.B	6
FZ1, '06-'11	GPT.06.541.100	4
FZ1, '05 & Earlier	GPT.06.238.100	4
FZ8, '10-'11	GPT.06.171.10000.B	4
FZ6R, '09-'11	GPT.06.479.10000.B	4
FZ6 S2, '07-'11	GPT.06.313.100	4
FZ6, '04-'06	Contact Us	1
Majesty 400, '04-'08	Contact Us	1
Majesty 400, '09-'11	Accessory carrier ABA-5RU61-30-00	6
Raider, '08-'09	Accessory carrier STR-5C751-30-00	6
T-Max 500, '09-'11	Accessory carrier	1
V-Max, '09-'11	Accessory carrier 2S3-F48B0-V0-00	6
V-Star 250, '08-'11 / Virago 250, '88-'07	Accessory carrier STR-0SS56-12-31	6, 7
V-Star 1100 & V-Star Custom	Accessory carrier STR-5EL51-10-00	6, 7
WR250R & WR250X, '08-'11	Accessory carrier ABA-32C51-00-00	6
XT600E, '90-'03	GPB.06.239.100	6
XT1200Z Super Tenere, '10-'11	GPT.06.148.10000.S	4
Zuma 125	Accessory carrier ABA-32S51-00-00	6

Adapters to fit Coocases onto other brands of aftermarket topcarriers

If noted in the chart, the following additional hardware is required for easiest installation:

1	Requires Aftermarket Toprack Adapter Kit 3	CC.HB-01
3	Requires Aftermarket Toprack Adapter Kit 2	GPT.00.152.157_TWT
4	Requires adapter for SW-Motech Alu-Rack (see page 82)	
	For S28 and V37 topcases	GPT.00.152.46000.B
	For S50 topcase	GPT.00.152.46100.B
	Electric for S28 and V37 topcases	GPT.00.152.42000.B
	Electric for S50 topcase	GPT.00.152.46300.B
5	Requires drilling 2-4 mounting holes in original factory luggage rack	None - use plate included with Coocase
6	No adapters or modification required	None - use plate included with Coocase
7	Must remove original sissy bar if present	None - use plate included with Coocase

"Original carrier" means the OEM carrier that always comes with the purchase of the bike

"Accessory carrier" means the optional OEM carrier that can be added to the bike

Coocase S50 mounted to an SW-MOTECH ALU-RACK on a Triumph Tiger 1050.
GPT.11.619.100





Givi Monokey luggage cases are waterproof, lockable, heavy-duty cases designed for use with motorcycles and large scooters. Accessories available for Givi Monokey topcases include inner nylon liner bags, brake lights, backrests, and steel topacks that can be used to attach large bulky items (e.g., tent or sleeping bag) to the lid of your topcase. All Givi cases can be locked, unlocked, and removed from the bike with just one key. Givi Monokey cases can be used as both sidecases and topcases. Givi Monokey cases cannot be attached to Givi Monolock luggage carriers but are compatible with bike specific topacks and sidecarriers manufactured by Givi and SW-MOTECH (sold separately). We carry all luggage racks from these manufacturers. See page 156-227, call us or visit www.TwistedThrottle.com for bike-specific fitting information!

E21 (Pair) - Sidecases (21L) \$169.20



7.5" D x 13.5"H x 16.5" L

E41 (Pair) - Sidecases (41L) \$486.90



11" D x 17"H x 22" L

V46 - Topcase (46L) \$245.70



17" D x 13"H x 22" W



V46NT (Clear Lens) \$245.70

17" D x 13"H x 22" W

E360 - Topcase / Sidecase (40L) \$195.30
Sold Individually



11" D x 17"H x 22" L

E460 - Topcase / Sidecase (46L) \$208.80
Sold Individually



17" D x 12"H x 22" W

E52 - Topcase (52L) \$279.00



16.8" D x 11.5"H x 23" W

E36- Topcase / Sidecase (36L) \$137.70
Sold Individually



10.8" D x 16.3"H x 22" L

E45 - Topcase / Sidecase (45L) \$140.40
Sold Individually



12" D x 16.3"H x 22" L

E55 - Topcase (55L) \$306.00



18.9" D x 12.6"H x 23.2"L

E55NT (Clear Lens) \$306.00



18.9" D x 12.6"H x 23.2"L

Case	# of Helmets	Colors
E36	Cannot fit	NJ - matte black w/o trim or internal straps
E360	1	N - matte black
E45	2	NJ - matte black w/o trim or internal straps
E460	2 small	N - matte black
V46	2 small	N - matte black NF - matte black with stoplight (pre-installed) A900 - satin silver N902 - gloss black G730 - gloss silver * Additional C46 bike-specific color plates available.
E52	2 large	N - matte black NF - matte black with stoplight (pre-installed) N902 - gloss black G730 - gloss silver
E21 (ea)	Cannot Fit	N - matte black N902 - gloss black G730 - gloss silver
E41 (ea)	1	NN - matte black N - satin silver G730 - gloss silver
E55	2 large	N - matte black A900 - satin silver N901 - metallic flake black N902 - gloss black G730 - gloss silver R301 - candy apple red B508 - dark blue

We also carry the full range of Givi Monolock topcases. Visit TwistedThrottle.com for details!

*The prices listed on this page are for cases in matte black finish. If you choose a different finish the price will be higher.



Givi V35 PLX Sidecases

This sidecase system hugs the tail section of your bike, providing a sleek, integrated look to your luggage. For use with only Givi PLX sidecarriers and SW-MOTECH Contour Carriers (see page 87). V35 sidecases cannot typically hold a full-face helmet. Sold in pairs.

Satin Silver (A900)



Gloss Silver (G730)



Matte Black (N)



Gloss Black (N902)



Dimensions: 20.7"W x 12.4"D x 15.5"H
 Weight capacity: 22 lbs per sidecase
 Volume: 35 liters/case
 GIVI V35N Matte Black: **\$490.50/pair**
 GIVI V35A900 Satin Silver: **\$529.20/pair**
 GIVI V35 Gloss Colors: **\$549.00/pair**

**The prices listed above are for cases in the matte black finish. If you choose a different finish the price will be increased.*

Givi TREKKER Luggage

Available in 46 liter and 33 liter sizes, TREKKER cases can be used as sidecases or topcases. TREKKER cases are constructed of rugged, durable plastic with a metallic finish.

Their unique design allows you the option to open either the entire lid or just the smaller upper opening. This allows easy access to gear when using the cases as sidecases WITHOUT accidentally emptying your sidecases onto the pavement.

Sold individually or in a 3 piece set:

33L (20" x 16.2" x 9.1")
 GIVI TRK33N: **\$288.00**

46L (20" x 16.2" x 12.2")
 GIVI TRK46N: **\$301.50**

3-pack (two 33L cases and one 46L case)
 GIVI TRKPACK3: **\$832.50**

TREKKER Sidecase Mounting Options:

- Givi Monokey bike-specific sideracks.
- SW-MOTECH bike-specific siderack with Givi Monokey adapters.

TREKKER Topcase Mounting Options:

- Givi Monokey bike-specific topracks.
- SW-MOTECH bike-specific topracks with Givi Monokey adapter.



TREKKER as sidecase



TREKKER as topcase



LED Lighting for Hard Luggage



Starting At
\$99⁹⁹

While Coocase & Givi offer basic add-on brake lights for a few topcase models, AdMore Lighting's LED conversion kits kick it up a notch. AdMore Lighting provides super-bright brake lights, running lights, and turn signals for many popular models of Givi and other hard-shelled cases.

Why use one of Admore Lighting's LED kits? Simply put, they're brighter, consume less power, and are more durable and longer lasting than incandescent bulbs.

Each easy-to-install LED light kit includes LED light strips, wiring connectors, mini controller, and easy-to-follow instructions.



Givi E52 with AdMore Lighting



Givi E460 with AdMore Lighting



Givi E41 with AdMore Lighting



Givi E370 with Admore Lighting



Givi E470 with Admore Lighting



Installation of brake, running, and turn signal kits requires drilling a hole in your Givi case to accommodate AdMore Lighting's proprietary wiring connector (drill bit included).



SCAN HERE for a video of the AdMore light kit for the Givi E52 topcase & E41 sidecases.



Givi Case	Orientation	Function	Part No.
E360	Sidecase	running/brake/turn	AML.LED360.S.TS
E360	Topcase	running/brake/turn	AML.LED360.T.TS
E370	Topcase	running/brake/turn	AML.LED370.T.TS
E450	Topcase	running/brake/turn	AML.LED450.T.TS
E460	Sidecase	running/brake/turn	AML.LED360.S.TS
E460	Topcase	running/brake/turn	AML.LED460.T.TS
E470	Topcase	running/brake/turn	AML.LED470.T.TS
V46	Topcase	running/brake only	AML.LEDV46.T
V46	Topcase	running/brake/turn	AML.LEDV46.T.TS
E52	Topcase	running/brake/turn	AML.LED52.T.TS
E55	Topcase	running/brake/turn	AML.LED55.T.TS
E41	Sidecase	running/brake/turn	AML.LED41.S.TS
V35	Sidecase	running/brake/turn	AML.LEDV35.S.TS



Quick-Release Brake Light/Running Light Conversion Kits

Do you already have an original Coocase or Givi brake light kit and want to upgrade to a brighter LED brake light/running light? Check out AdMore Lighting Mini Kits to retain Givi's quick-release hands-free connector functionality without drilling any holes in your case! Mini Kits require an existing Coocase or Givi brake light connector kit and do not provide turn signal functionality.

Case	Orientation	Function	Part No.
Coocase S48 & S50*	Topcase	running/brake only	AML.LED.CCS48.T
Givi E450	Topcase	running/brake only	AML.LED450.TM
Givi E460	Topcase	running/brake only	AML.LED460.TM
Givi E470	Topcase	running/brake only	AML.LED470.TM
Givi V46	Topcase	running/brake only	AML.LEDV46.TM
Givi E52	Topcase	running/brake only	AML.LED52.TM

* Compatible with Volt cases only



Starting At
\$69⁹⁹

Coocase S48 with Mini Kit

Self Adhesive Flush-Mount LED Light Kits

Extra lighting! Extra Safe!

Starting At
\$119⁰⁰

Nuclear Firestorm Flush-Mount LED Kits (includes brake light, running light, and turn signal functions)

Our flush-mount LED kits transform your two-wheeled stealth fighter into a blazing ball of light that no mortal eyes can miss. While designed primarily for installation on the flat rear surfaces of aluminum sidecases or topcases, these LEDs can be installed on any flat surface. The kit's dual-intensity (high and low) LED strips are clear when turned off, but bright red when energized.

The kit is easy to install and significantly enhances your visibility on the road and the good looks of your luggage. Each kit contains two self-adhesive high-intensity weatherproof LED strips and a mini controller harness for splicing into your running, turn signal, and brake light wires. The mini controller embedded in the main harness fits neatly under your motorcycle/scooter seat or behind the taillight assembly. The kit also includes a quick-release mechanism so that the wiring won't interfere with the removal of your cases. Once installed, the LEDs will glow at low intensity when riding, brighten when you apply your brakes, and flash at high intensity with your turn signal lights.



Without extra lighting, you're in stealth mode... Not good!

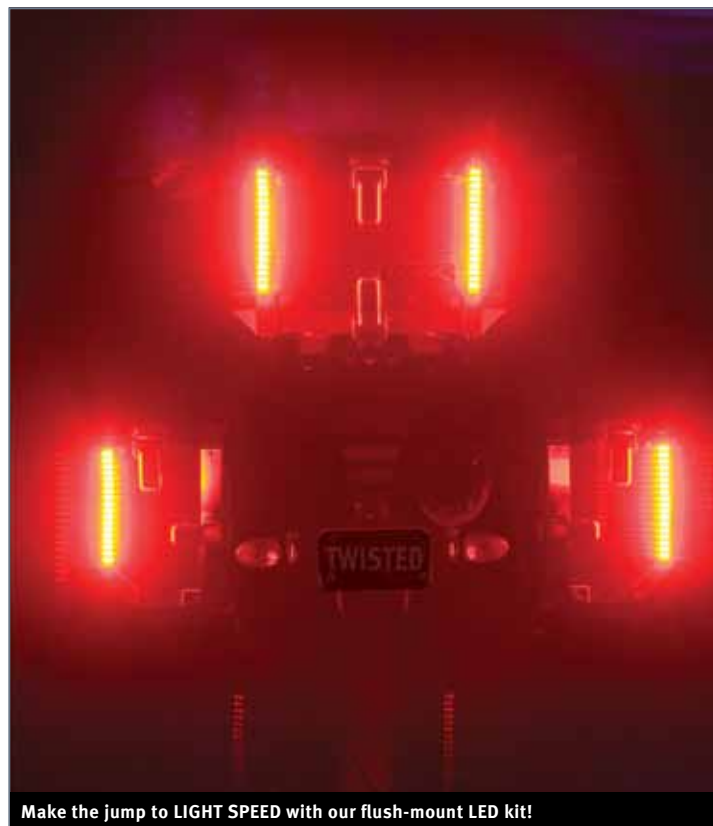

Make the jump to LIGHT SPEED with our flush-mount LED kit!

Flush-Mount LED Kit	Dimensions	Part No.	Price
Sidecase Kit	Incl. two 5.5" x 0.5" x 0.25" LED strips	AML.LED.4014.S.TS	\$129
Topcase Kit	Incl. two 5.5" x 0.5" x 0.25" LED strips	AML.LED.4014.T.TS	\$119

Starting At
\$22⁵⁰

Tired of not being seen at night?

ReflectGard reflective kits add a custom-cut piece of automotive-grade 3M Scotchlite™ reflective sheeting to your motorcycle, helmet, or even your luggage, making you more visible when targeted by another vehicle's headlights! These custom-fabricated kits make your Givi, Coocase, and TraX ALU-BOX cases both highly reflective and easily noticed. All kits come with detailed application instructions. The black reflective tape is invisible against black surfaces until it is hit by light; perfect for when you want to be subdued or discreet.

Coocase V28 without ReflectGard – Not much to look at, right?



Coocase V28 with ReflectGard – Roswell aliens got nuthin' on you!



GIVI V46 Top case without ReflectGard – Stealth Mode is not good for bikers.



GIVI V46 Top case with ReflectGard – your bike's got afterburners!



TraX ALU-BOX cases with black Reflectgard kit in normal lighting conditions.



TraX ALU-BOX cases with black ReflectGard kit reflecting high beams.



Visibility Kits for Aftermarket Hard Luggage

Givi Luggage	Notes	Part No.
Givi E28, E36, & E45 topcase		JMH.R5003
Givi E36 case		JMH.R5003
Givi E360 case		JMH.R5001
Givi E370 topcase		JMH.R5009
Givi E45 case		JMH.R5003
Givi E450 topcase		JMH.R5008
Givi E460 case		JMH.R5001
Givi E470 topcase		JMH.R5010
Givi V46 topcase		JMH.R5007
Givi E50 & E52 topcase		JMH.R5002
Givi E21 sidecases	Kit for pair of sidecases.	JMH.R5004
Givi E41 sidecases	Kit for pair of sidecases.	JMH.R5005
Givi V35 sidecases	Kit for pair of sidecases.	JMH.R5011
TraX ALU-BOX cases	Notes	Part No.
TraX topcase, black		JMH.RG-TRXTC-02.B
TraX sidecases, black	Kit for pair of sidecases.	JMH.RG-TRXSC-01.B
Coocase Topcases	Notes	Part No.
Coocase V28 topcase		JMH.RG-CC01-V28
Coocase V36 & V37 topcases		JMH.RG-CC02-V36
Coocase S48 & S50 topcases		JMH.RG-CC03-S48
Micotech V2 Sidecases	Notes	Part No.
V2 sidecases, black	Fits 37-liter and 45-liter cases.	JMH.RG-MTV2001.B
V2 sidecases, silver	Fits 37-liter and 45-liter cases.	JMH.RG-MTV2001.S

Helmet with ReflectGard Kit.



Helmet Visibility Kits	Part No.
Helmet visibility kit, black	JMH.R1019
Helmet visibility kit, white	JMH.R1020

Twisted Throttle Reflective Stickers



Twisted Throttle Sticker
Reflective vinyl bumper sticker shines like the sun when targeted with a nighttime headlight beam. Great for increasing rider visibility when used on a motorcycle helmet, bumper, or hard luggage.

Equilateral triangle; each side is 3.75" long.

TT.STK.01: \$1.00

Don't see a kit for your case?

Order Bulk Visibility Tape and make your own!

Bulk Visibility Tape		Part No.
Bulk ReflectGard tape, black	12" x 15" sheet.	JMH.R10-1215.B
Bulk ReflectGard tape, white	12" x 15" sheet.	JMH.R10-1215.W



AdMore LED Light Bars get attention!

Includes running light, modulated brake light, and turn signals. When you brake, a built-in brake-light modulator causes the light bar to flash 3 times before turning solid at 100% intensity, helping to alert drivers behind that you are slowing down or stopping. When a turn signal is on, the LEDs on the turning side flash yellow while the remainder of the LEDs stay red and operate normally as running and taillights. Both light bars mount easily to any flat surface, license plate bracket, or the underside of most rear luggage racks, with or without a topcase mounted, using the included hardware.

Housed in a black polycarbonate case with clear lens.

Provides:

- Red tail light (50% intensity)
- Red brake light (maximum intensity)
- Yellow turn signals

AdMore simplifies installation by providing Posi-Tap™ electrical connectors, which allows you to wire the light bar to your original wiring harness without tools; no stripping, crimping, or soldering required!

AdMore Light Bars are CANbus compatible.

AdMore Large LED Light Bar

\$139⁰⁰

This large 10.75" light bar enhances visibility and safety!
Fits well on large touring motorcycles as well as 4-wheeled vehicles.

When a turn signal is on, two of the four clusters will flash yellow.

Constructed of 72 high-intensity **bi-color LEDs**.
Approximately 10.75" across, 1.625" tall, and 1" thick.



Scan here to watch the demonstration video.

AML.LED.U.7226NTTS



AdMore Mini LED Light Bar

\$129⁰⁰

The Mini 8" light bar gets attention!
Similar to the large light bar, but 8-inches wide. Fits well on the license plate brackets of most motorcycles.

Constructed of 54 high-intensity **bi-color LEDs** in three clusters.

Approximately 8" across, 1.25" tall, and 1" thick.



AML.LED5420.T.TS





Rider Grip

Give your passenger peace of mind with the Oxford Rider Grip. Rider Grips provide a secure handhold for greater comfort and security, especially on motorcycles without grab rails.

- Offers true long distance comfort for your pillion.
- Comfortable, ergonomic design.
- Fully adjustable double belt system.
- Mesh inner lining to increase breathability.
- Fits waist sizes from 36" to 50" while wearing outer jacket.
- 3M™ high visibility reflective piping.



\$29⁹⁹

OXF.OF589



Visor Transporter

It's important to be able to see clearly for safety. For riders who use dark shields, this means carrying a clear visor for cloudy days, inclement weather or nighttime riding. The Stowaway Visor Transporter saves your spare helmet visor from scratches and other damage.

- Accommodates most visors.
- Included quick-release carrying belt is ergonomically shaped to hug your waistline.
- Soft anti-scratch lining.
- Made from tough 840 denier nylon-backed polyester.



\$9⁹⁹

OXF.OF588

Clear Shot Lens Cleaning Kit

\$19⁹⁵

CLR.100

Clear Shot is an all-in-one, compact anti-fogging/lens cleaning kit perfect for safely cleaning all types of lenses, including goggles, and helmet visors. Designed for easy use without removing your gloves. Included 1 oz. spray will last a few weeks of dirty, all-day riding or 3 to 6 months of commuting. 8 oz. refill bottle available. Cases are available in Cobalt Blue, Racing Red, Safety Orange, and Matte Silver

How to use:

- Open the caps and remove the spray.
- Pick a cloth. Use blue for grime and white for polishing.
- Spray and wipe clean.
- Put fluid and cloths away and stow case.

Clear Shot kit includes:

- Rugged ABS case (choice of four colors).
- 1oz. anti-fog cleaning spray.
- Blue micro-fiber cloth for removing grime.
- White micro-fiber polishing cloth.

8oz. refill bottle:
CLR.1131: **\$16.95**



Stash Box lockable license plate storage box

The Stash Box is a weather-resistant storage box that mounts between the motorcycle's fender and the license plate. It is ideal for storing your registration, wallet, and other small objects. The Stash Box is unobtrusive, inexpensive, and secure

- Sized to work with all standard license plates.
- External Dimensions: 7" x 4" x 1" (plus 1" lock assembly).
- Internal Dimensions: 6.3" x 2.2" x 0.8".
- Includes lock and two keys.
- Made from molded polypropylene.
- Includes all mounting hardware, retention pouch for paper documents, and foam insert.

\$19⁹⁹

TT.SBX.10000





The Fastest, Cleanest Way to Mount a Tankbag

QUICK-LOCK EVO tankrings are an innovative way to mount Bags-Connection Quick-Lock tankbags.

Features:

- Allows tankbags to be securely attached and detached in seconds.
- No magnets; works with plastic and aluminum tanks.
- No straps; won't scratch the paint on your tank.
- Tankring bolts to gas cap using included screws; no drilling or tank modification required.
- Tankring does not interfere with gas cap use.
- Location of tankbag is customizable by mounting the topping further forward or back on the bottom of the tankbag.

Once you've installed the Tankring, attaching your tankbag is easy!

QUICK-LOCK Tankbag attachment instructions:

STEP 1

 Position tankbag directly over tankring.

STEP 2

 Press down on tankbag, locking it into position.

Detach the tankbag with one hand in one second!

QUICK-LOCK Tankbag detachment instructions:

STEP 1

 Pull cord to release locking mechanism.

STEP 2

 Lift bag up.

QUICK-LOCK Tankring adapter kits for fuel tanks without traditional gas cap rings

\$79⁹⁹

Does your bike lack a gas cap ring?

There are a limited number of bikes that make it a little difficult to mount a QUICK-LOCK Tankring and tankbag. But rest assured, SW-MOTECH has the solution.

With the QUICK-LOCK Tankring Adapter Kit you can mount Bags-Connection tankbags directly to your bike. The included hardware utilizes your bike's factory threaded holes making installation super easy.

Adapter for bikes without gas caps

BMW	from	to	Part No
G 650 GS	'11	'12	TRT.00.640.20500.B
F 650 GS	'08	'12	TRT.00.640.20100.B
F 800 GS	'08	'12	TRT.00.640.20100.B
F 800 R	'09	'12	TRT.00.640.20600.B
Ducati	from	to	Part No. (Pass)
696 Monster	'09	'12	TRT.00.640.20300.B
1100 Monster	'09	'12	TRT.00.640.20300.B

Adapter for BMW bikes with screwless gas cap

BMW	from	to	Part No
R1200GS	'08	'12	TRT.00.640.12300.B
R1200GS	'09	'12	TRT.00.640.12700.B
R1200GS Adv.	'08	'12	TRT.00.640.12300.B
R1200GS Adv.	'09	'12	TRT.00.640.20700.B
R1200R	'07	'12	TRT.00.640.20400.B
R1200R	'09	'12	TRT.00.640.20800.B
R1200R	'11	'12	TRT.00.640.20801.B
R1200S	'07	-	TRT.00.640.12300.B



BMW G 650 GS - TRT.00.640.20500.B \$79.99



Ducati Monster 696 - TRT.00.640.20300.B \$79.99

Tankring Adapter Kits for Rear Luggage Racks

Want to mount a tankring to your tail section? It's easy with this rear luggage rack adapter.

ALU-RACK adapter for QUICK-LOCK EVO Tankbags

Attach and detach the tankring adapter in seconds with the QUICK-LOCK fastener. Simply fit the adapter into the rack cutout and then turn the fastener to secure the adapter to the rack.

\$74⁹⁹

TRT.00.640.20400.B

What's in the kit:

- QUICK-LOCK EVO Tankring Adapter
- QUICK-LOCK EVO Tankring

See page 82 for more information on ALU-RACKS (ALU-RACK sold separately).

STEEL Toprack adapter for QUICK-LOCK EVO Tankbags

Permanently installs a Tankring onto your Steel Toprack using through bolts.

\$39⁵⁰

TRT.00.640.13500.B

What's in the kit:

- QUICK-LOCK EVO Tankring
- Mounting hardware

See page 80 for more information on Steel Topracks (Steel Topracks sold separately).



Compatible tankbags: Sport, Micro, and Daypack (see pages 127-129)



Add electrical power to your QUICK-LOCK Tankbag!

You will need to buy a QUICK-LOCK Tankbag and an electric tankbag mounting kit for your bike. Here's how to install it:

STEP 1 Install an Electric QUICK-LOCK Tankring on your tank's gas cap.

Bolt the tankring onto your gas cap, then run the power cable under the front of the tank.



Connect the tankring's power cable to the motorcycle's battery.



STEP 2 Install an QUICK-LOCK Electric Topping onto the bottom of a QUICK-LOCK Tankbag.



The Electric Tankring attaches to the bottom of a QUICK-LOCK tankbag with 4 bolts. Drill a fifth hole in the bottom of the bag and pass the SAE cable inside.

The Electric Tankring wires run up through a hole in the bottom of the tankbag and terminate in an SAE connector.



The tankbag's SAE connector allows you to charge cell phones, cameras, iPods and other gadgets through the tankbag.

STEP 3 Distribute electrical power within the tankbag.

Connect an electrical socket of your choice to the SAE connector.

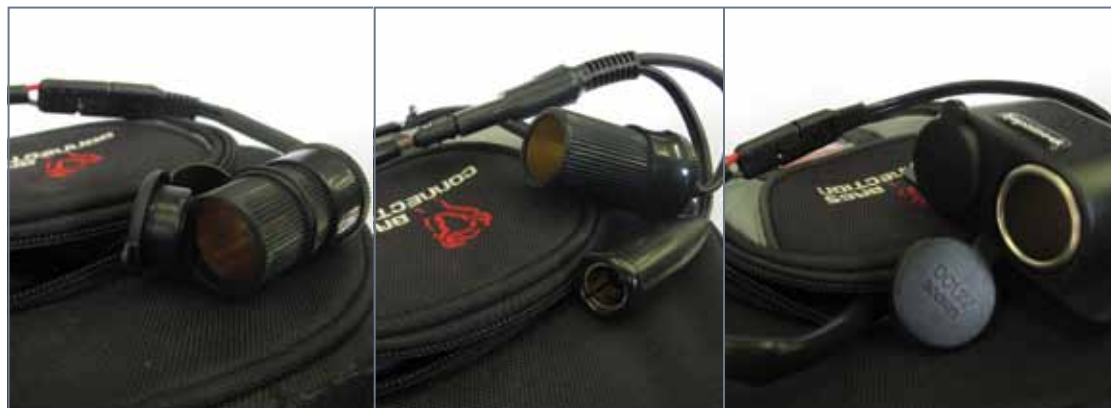

Single cigarette socket

BC.POW.00.008.1000 \$17.99

Cigarette socket & mini-Euro socket

BC.POW.00.009.1000 \$39.99

Dual cigarette socket

BC.POW.00.010.1000 \$34.99

USB Charging Adapter

Converts a 12-Volt cigarette socket into a USB socket, allowing you to charge any device that you normally charge via a computer's USB port.



BC.POW.00.012.100 \$14.99

Mounting Options for QUICK-LOCK Tankbags:

Non-Electric Tankring

Starting At
\$39⁵⁰

Buy this if you want to attach a non-electric QUICK-LOCK tankbag to your motorcycle, (QUICK-LOCK tankbag sold separately).

Complete Electric Tankbag Kit

Starting At
\$154⁹⁹

Buy this if you plan on purchasing a new bag. (QUICK-LOCK tankbag sold separately - see below).

Electric Tankring

Starting At
\$89⁹⁹

Buy this if you already own an electrified QUICK-LOCK tankbag and want to attach it to a second motorcycle.

Motorcycle Manufacturer*	Compatible gascaps	Non-Electric Tankring	Complete Electric Tankbag Kit	Electric Tankring
Aprilia	6 screws.	TRT.00.640.175	TRE.175	TRE.00.475.175
Benelli	6 screws. Also fits Cagiva models with 6-screw gascaps.	TRT.00.640.190	TRE.190	TRE.00.475.190
BMW	6 screws - Type 1. Fits most recent models through 2007.	TRT.00.640.120	TRE.120	TRE.00.475.120
BMW F650 ST & F650 Funduro (1993-1996)	5 screws.	TRT.00.640.118	TRE.118	TRE.00.475.118
BMW F650 ST & F650 Funduro (1997-2000)	6 screws - Type 3. Fits only the models listed.	TRT.00.640.116	TRE.116	TRE.00.475.116
BMW R1200S (2006-2008) R1200GS, R1200GS Adventure & HP2 Sport (2008)	For use with gascaps without screws.	TRT.00.640.124	TRE.124	TRE.00.475.124
BMW R1200S, R1200GS, R1200GS Adventure, & HP2 Sport (2009 & Later)		TRT.00.640.12800	TRE.12800	TRE.00.475.12800
BMW R1200R (2006-2008)	For use with gascaps without screws.	TRT.00.640.123	TRE.123	TRE.00.475.123
BMW R1200R (2009 & Later)		TRT.00.640.12700	TRE.12700	TRE.00.475.12700
BMW R1200ST & R1200RT (2005 & later)	6 screws - Type 2. Fits only the models listed.	TRT.00.640.129	TRE.129	TRE.00.475.129
BMW K1300GT, K1300R, & K1300S		TRT.00.640.126	TRE.126	TRE.00.475.126
Cagiva	6 screws.	TRT.00.640.190	TRE.190	TRE.00.475.190
Ducati	5 screws.	TRT.00.640.110	TRE.110	TRE.00.475.110
Honda	7 screws.	TRT.00.640.106	TRE.106	TRE.00.475.106
Kawasaki	5 screws.	TRT.00.640.140	TRE.140	TRE.00.475.140
Kawasaki	7 screws.	TRT.00.640.135	TRE.135	TRE.00.475.135
KTM	6 screws. Fits SuperDuke and other KTM models with 6-screw gascaps.	TRT.00.640.170	TRE.170	TRE.00.475.170
Moto Guzzi	6 screws.	TRT.00.640.180	TRE.180	TRE.00.475.180
MZ	6 screws.	TRT.00.640.165	TRE.165	TRE.00.475.165
Triumph	6 screws.	TRT.00.640.160	TRE.160	TRE.00.475.160
Suzuki	5 screws.	TRT.00.640.125	TRE.125	TRE.00.475.125
Suzuki	7 or 8 screws. Also fits in Hyosung & Fischer motorcycles.	TRT.00.640.115	TRE.115	TRE.00.475.115
Victory (2005 & Later)	5 screws. Fits all models 2005 & later except Arlen Ness models.	TRT.00.640.110	TRE.110	TRE.00.475.110
Yamaha	5 screws.	TRT.00.640.110	TRE.110	TRE.00.475.110
Yamaha	7 screws.	TRT.00.640.115	TRE.115	TRE.00.475.115

* For gas tanks without traditional gas caps see page 121.

Fit kits for other tanks	Notes	Part No.
Adjustment kit for curved tanks	Allows easier attachment/detachment to steeply sloped tanks by lowering the rear slots in the tankbag. Useful for installation on ST1300, Tiger 1050, most BMW K-bikes, and many others.	TWT.TR.00.005.100
Drill-on electrical bottom tankring kit	For BMW F650GS & F650GS/Dakar, '07, F800S, F800ST, & Buell Ulysses.	TWT.TRE.00.006.100

Electrical Tankbag Wiring Accessories	Notes	Part No.
QUICK-LOCK Electrical Tankring	For use with corresponding electrical bottom ring to electrify a QUICK-LOCK tankbag.	TRE.00.475.102
Splitter (bullet connector style)	Allows connection of an additional sockets inside tankbag (sold separately).	TT-00005
SAE Adapter	For use with splitter (sold separately). Converts original bullet connectors within an electric tankbag into an SAE connector.	TT-00004

Complete Electric Tankbag Kits Include:

1. Electric Topring

This electric topring replaces the original non-electric tankbag ring on a Bags-Connection QUICK-LOCK tankbag so that it can be used with an electrified tankring. (Not for sale without purchase of a Bags-Connection QUICK-LOCK tankbag).

2. SAE adapter

Converts the bullet connectors on the QUICK-LOCK Electric Tankring into an SAE connector.

3. QUICK-LOCK Electric Tankring

The QUICK-LOCK Electric Tankring includes a pre-assembled, fused wiring harness for direct attachment to your battery terminals. Compatible with all QUICK-LOCK tankbags.

(QUICK-LOCK tankbag and electrical sockets sold separately)



Gadget Mounts and Map holders for QUICK-LOCK Tankbags



GPS/Phone/Radar Bracket

Features:

- The GPS/PDA bracket slides into two sleeves at the front of the tankbag.
- For use with:
 - all Bags-Connection device pockets (see page 59),
 - all RAM, Garmin Zumo, and TomTom Rider device cradles (see page 58)
 - all other device cradles with an AMPS hole pattern (see page 59-60).
- Weather-resistant GPS/PDA bags have eyelets on their edges to pass through electrical or audio cables (see below).



Dimensions: 6 1/4"L x 4 1/2"W x 1 1/2" deep
BCK.GPS.00.010.100: **\$46.50**



Simply slide the bracket into the sleeves on the bag and snap.

Fits the following tankbags:

- Daypack
- City
- Engage
- GS
- Trial
- Enduro
- Sport
- Enduro LT

(see pages 127-135 for QUICK-LOCK Tankbags)

Gadget Pouches and Dry Bags

GPS/PDA Pockets with Sun Visor

Weather-resistant, splash-proof GPS/PDA bags are perfect for navigation devices and smart phones. Bags feature a sturdy base for secure mounting and eyelets to pass-through electrical or audio cables. Mounts directly to a RAM-B-238 base, any Techmount, or any SW-MOTECH GPS holder. iPhone and Android touch-screens can be used through the clear window. The pocket's perimeter zipper makes accessing your device extremely fast, but also makes the pocket somewhat permeable to heavy downpours. If you need a 100% weatherproof solution and don't mind slower entry, use the roll-top GPS Dry Bag.



Medium Pocket fits Garmin Nuvi 30, 40, 1350, 3750, 2300LM, Tom Tom XXL 540TM, Go2435, Magellen 1424, and similar.
Dimensions: 5.7" x 3.7" x 1.4" deep
BC.GPS.00.003.1000: **\$34.99**



XL Pocket
The extra-large bag provides even more depth compared to the large bag. Fits some XM radios and GPS units.
Dimensions: 5.7" x 3.9" x 3.0" deep
BC.GPS.00.001.1000: **\$47.99**



AMPS pattern fitment

Small Pocket

Fits Apple iPhones, Samsung Nexus, Motorola Atrix, HTC EVO 4G and similar.
Dimensions: 5.3" x 3.5" x 1" deep
BC.GPS.00.004.1000: **\$29.99**



Large Pocket

The large bag provides extra depth for thicker PDAs.
Dimensions: 5.7" x 3.9" x 1.8" deep
BC.GPS.00.002.1000: **\$42.99**



GPS Dry Bag

100% weatherproof (not submersible)
Fits apple iPhones, Samsung Nexus, Motorola Atrix, HTC EVO 4G and similar.
Dimensions: 5.3" x 3.5" x 1.2" deep
BC.GPS.00.005.1000: **\$34.99**

Lighting Accessories for QUICK-LOCK Tankbags

12-volt LED map light panel



BCK.TRE.00.036.100: \$39.99

12-volt LED map light panel in use



Rechargeable Mini Flashlight



*It's only 2 inches long!
Recharges in your tankbag's
cigarette socket.
NEB.HB: \$9.99*

A perfect tankbag lighting solution!



Map light requires mini-Euro socket. Flashlight requires full sized cigarette socket (see page 61-62 for more info).

Map Holder for QUICK-LOCK Tankbags

Fits the following tankbags: Daypack, Engage, Sport, Trial, Enduro, Enduro LT, City, and GS



Dimensions:
Exterior - 10"W x 10.5"L
Interior - 9.5"W x 10"L

BC.TRS.00.150.1000: \$29.99



*Note: Map Holder is equipped with a touch sensitive membrane that allows gadgets like iPhones and Android smartphones to be operated when in mapholder.

Dry Bag Device Holders for Bags-Connection Tankbags

These roll-top welded dry bags are sized to hold your smartphone or tablet and are 100% weatherproof (not submersible).

The dry bags can be securely connected to all Bags-Connection tankbags except the "Micro".

iPhone and Android touchscreens can be used through the clear window!

Smartphone Dry Bag

Holds Apple iPhones and most Android smartphones.

BC.TRS.00.152.10000 \$34.99



iPhone 4s inside Smartphone Dry Bag.
Shown mounted on an Engage Tankbag.

Tablet Dry Bag

Holds an Apple iPad!

BC.TRS.00.151.10000 \$59.99



iPad 2 inside Tablet Dry Bag.
Shown mounted on a Sport Tankbag.



QUICK-LOCK Tankbags



This year's BAGS-CONNECTION product line sets a new standard for quality and refinement in motorcycle touring luggage. Using extra-durable materials with smart features, these premium-quality bags fit perfectly on a wide variety of motorcycles.

Your new Bags-Connection bags might be the last motorcycle luggage you ever buy.



Tankbag Features:



All QUICK-LOCK tankbags include a 100% weatherproof rain cover with a clear map window.



GPS mount sleeves provide a secure, quick way to add a GPS mount to your tankbag. Available for all tankbags except the Micro.



All bags have cable pass-throughs. The forward cable pass-through can be used to run GPS/gadget wires, and the rear pass-through can be used for headphone cables or a hydration straw.



Interior lid organizer; configuration varies among bags.



Need more space? Unzip the expansion zipper and increase the volume of your bag!



Keep the interior neat and tidy with lid and wall organizer pockets (both sides of the bag) and elastic cable organizer straps (right side),



Lock the bag to the bike with the available Lock Pin (sold separately).



Super durable 1680 Ballistic nylon has higher abrasion and tear resistance than most materials found in armored riding jackets.



Zipper keepers keep zipper pulls from flapping around. Say that 5 times fast!



NEW
Tankbag
for 2012

Sport QUICK-LOCK Tankbag

This large tankbag fits wide flat tanks found on modern sportbikes, including most Honda CBR, Kawasaki Ninja, Suzuki GSX-R, and Ducati super sport models.

- Includes rain cover, QUICK-LOCK Topring, and shoulder strap.
- 2 exterior pockets and 1 main compartment
- Interior lid and wall organizer pockets
- Lockable main compartment zippers
- Front and rear cable pass-through
- Integrated GPS Mount Sleeves
- Carry handle on front of bag
- 1680 Ballistic Nylon

BC.TRS.00.101.2000

\$254⁹⁹

*Note: This bag will work as a tailbag (see page 81).



GPS Bracket inserted into integrated GPS Mount Sleeves (bracket sold separately).



FITS
WIDE
FLAT
TANKS



ORIGINAL
QUICK-LOCK
SINCE 1999

QUICK-LOCK Tankbags



NEW
Tankbag
for 2012

Micro QUICK-LOCK Tankbag

This extra-small tankbag fits all tanks and provides just enough storage for your wallet, sunglasses, and a few other small items.

- Includes rain cover and QUICK-LOCK Topring
- 1 main compartment
- Interior lid and wall organizer pockets
- Lockable main compartment zippers
- Front and rear cable pass-throughs
- Zipper keeper for expansion zipper
- Does not have GPS mount sleeves
- Carry handle on front of bag
- 1680 Ballistic Nylon

BC.TRS.00.110.2000

\$89⁹⁹

*Note: This bag will work as a tailbag (see page 81).



Rear cable pass-through



Expands to 5 liters





NEW
features
for 2012

Daypack QUICK-LOCK Tankbag

This small tankbag fits all tanks and provides ample room for a wallet, sunglasses, and other basics for a commuting or short day trips.

- Includes rain cover and QUICK-LOCK Topping
- 1 main compartment
- Interior lid and wall organizer pockets
- Lockable main compartment zippers
- Front and rear cable pass-throughs
- Zipper keeper for expansion zipper
- Integrated GPS mount sleeves
- Carry handle on front of bag
- 1680 Ballistic Nylon

BC.TR5.00.108.2000

\$119⁹⁹



Reflective material

Rear cable pass-through

*Note: This bag will work as a tailbag (see page 81).



GPS Bracket inserted into integrated GPS Mount Sleeves (bracket sold separately).



Expands to 7 liters



QUICK-LOCK Tankbags



NEW
features
for 2012

Engage QUICK-LOCK Tankbag

This medium-sized tankbag looks great on slightly sloped tanks found on many naked sportbikes, ie. Ducati Monster, Kawasaki ER-6n, and Triumph Street Triple.

- Includes rain cover, QUICK-LOCK Topping, and shoulder strap.
- 2 exterior pockets and 1 main compartment
- Interior lid and wall organizer pockets
- Lockable main compartment zippers
- Front and rear cable pass-throughs
- Integrated GPS mount sleeves
- Carry handle on front of bag
- 1680 Ballistic Nylon

BC.TRS.00.107.2000

\$169⁹⁹



Included rain cover



Optional map holder



GPS Bracket inserted into integrated GPS Mount Sleeves (bracket sold separately).



ORIGINAL
QUICK-LOCK
SINCE 1999



Trial QUICK-LOCK Tankbag

This large tankbag fits the same bikes as the Engage, and is also popular on the Suzuki V-Strom and other dual-sport bikes with slightly sloped tanks.

- Includes rain cover, QUICK-LOCK Topping, and shoulder strap.
- 2 exterior pockets and 1 main compartment
- Interior lid and wall organizer pockets
- Lockable main compartment zippers
- Front and rear cable pass-throughs
- Integrated GPS mount sleeves
- Carry handle on front of bag
- 1680 Ballistic Nylon

BC.TRS.00.102.2000

\$239⁹⁹

NEW
features
for 2012



GPS Bracket inserted into integrated GPS Mount Sleeves (bracket sold separately).



Expands to 22 liters

FITS
SLIGHTLY
SLOPED
TANKS



ORIGINAL
QUICK-LOCK
SINCE 1999

2012 Triumph Street Triple



NEW
features
for 2012

City QUICK-LOCK Tankbag

This medium-sized tankbag fits well on the steeply sloped tanks found on many dual-sport bikes, including the BMW R1200GS and Triumph Tiger 1050.

- Includes rain cover, QUICK-LOCK Topping, and shoulder strap.
- 3 exterior pockets and 1 main compartment
- Interior lid and wall organizer pockets
- Lockable main compartment zippers
- Front and rear cable pass-throughs
- Integrated GPS mount sleeves
- Carry handle on front of bag
- 1680 Ballistic Nylon

BC.TR5.00.104.2000

\$224⁹⁹



Reflective material

Rear cable pass-through



Zipper keepers
(on all three exterior pockets)

Expands to 15 liters



GPS Bracket inserted into integrated GPS Mount Sleeves (bracket sold separately).

FITS
STEEPLY
SLOPED
TANKS



ORIGINAL
QUICK-LOCK
SINCE 1999



NEW
features
for 2012

GS QUICK-LOCK Tankbag

This large tankbag suits riders that want to carry **EVERYTHING** on their tank. Originally designed for the R1200GS, this tankbag fits many large adventure bikes.

- Includes rain cover, QUICK-LOCK Topring, and shoulder strap.
- 3 exterior pockets and 1 main compartment
- Interior lid and wall organizer pockets
- Lockable main compartment zippers
- Front and rear cable pass-throughs
- Integrated GPS mount sleeves
- Carry handle on front of bag
- 1680 Ballistic Nylon

BC.TRS.00.103.2000

\$269⁹⁹



Reflective material

Rear cable pass-through

Zipper keepers
(on all three exterior pockets)



GPS Bracket inserted into integrated GPS Mount Sleeves (bracket sold separately).



Expands to 22 liters

FITS
STEEPLY
SLOPED
TANKS



ORIGINAL
QUICK-LOCK
SINCE 1999



Enduro Tankbag

This medium-sized tankbag fits well on the steeply sloped tanks found on many dual-sport bikes, including the BMW R1200GS and Triumph Tiger 1050.

- Includes waterproof inner bag (instead of rain cover), fitting straps with retention loop, and tank-protection film.
- 3 exterior pockets and 1 main compartment
- Interior lid and wall organizer pockets
- Lockable main compartment zippers
- Front and rear cable pass-throughs
- Integrated GPS mount sleeves
- Carry handle on front of bag
- Can be used as a backpack
- 1680 Ballistic Nylon

BC.TRS.00.130.1000

\$174⁹⁹



GPS Bracket inserted into integrated GPS Mount Sleeves (bracket sold separately).



Expands to 22 liters

NEW
features
for 2012

FITS
SLOPED TANKS



ORIGINAL
QUICK-LOCK
SINCE 1999



NEW
Tankbag
for 2012

Enduro LT Tankbag

This minimalist tankbag attaches to the bike with straps. The small size stays out of your way when standing on the footpegs during dirt riding. Perfect for smaller dual sport bikes like the Suzuki DR-Z400 or KTM 690 Enduro R. Also good for larger bikes like the BMW F800GS if you're the kind of guy that uses an adventure bike for motocross riding.

- Includes waterproof inner bag (instead of rain cover), QUICK-LOCK Topring, and shoulder strap.
- 1 main compartment
- Interior lid and wall organizer pockets
- Lockable main compartment zippers
- Front and rear cable pass-throughs
- Integrated GPS mount sleeves
- Carry handle on front of bag
- Can be used as a backpack
- 1680 Ballistic Nylon

BC.TR5.00.131.1000

\$109⁹⁹



GPS Bracket inserted into integrated GPS Mount Sleeves (bracket sold separately).



Expands to 7.5 liters



ORIGINAL
QUICK-LOCK
SINCE 1999



NEW
features
for 2012

Slipstream

- Includes waterproof inner bag, 4 elastic bungee cords, 2 backpack straps, and tank-protection film.
- 2 outer pockets and 1 main compartment
- Lockable main compartment zippers
- Can be used as a backpack

Volume: 13 liters
Dimensions: 14" L x 13" W x 8.5"H

BC.HTA.00.307.1000

\$154⁹⁹

Water resistant zipper

Exterior bungee tie-downs



4-point tie-down strap system



Can be used as a backpack



Outer compartments and bungee tie-downs



Water resistant zipper



- Fits on:
- All rear seats
 - Larger rear luggage racks

Not recommended for use with sissy bar racks.

This bag cannot accommodate a helmet.



Jetpack

- Includes rain cover, tank-protection film, and 2 adjustable fitting straps.
- 1 outer compartment and 1 main compartment
- Lockable main compartment zippers
- Can be used as a backpack

Volume: 20-33 liters
 Dimensions: 19" L x 13" W x 7"H

BC.HTA.00.303.1000

\$224⁹⁹



Can be used as a backpack. Shoulder straps double as front mounting straps.



Expansion zipper



Clean lines



Fits on:

- Rear seats of bikes without a backrest or topcase.
- Larger rear luggage racks.

This bag cannot be used on bikes with a backrest or topcase, as it overhangs past the rear of most passenger seats.

Not recommended for use with sissy bar racks.

This bag cannot accommodate a helmet.



NEW
features
for 2012

Rearbag

- Includes instructions, waterproof inner bag, 4 mounting straps, 2 backpack straps, and 2 license plate fittings.
- 2 separate outer compartments and 1 main compartment
- Carry handle
- Can be used as a backpack

Volume: 24-36 liters
Dimensions: 17.5" L x 13.5" W x 10"H

BC.HTA.00.304.1000

\$249⁹⁹



Interior lid organizer



Carry handle



Secure rear bag mounting



Fits on:
- All rear seats

Not recommended for use with rear luggage racks or sissy bar racks.

This bag can accommodate a full face helmet plus additional gear (when bag is expanded).

Expands to 36 liters

Elastic loops safely stow any excess strap length



Cargobag

- Includes waterproof inner bag, 4 mounting straps, 2 compression straps, 2 license plate strap mounts, and tank-protection film.
- 2 separate outer compartments and 1 main compartment
- Carry handle
- Integrated Tentbag tie-down points (see page 142)

Volume: 50 liters
 Dimensions: 27.5" L x 17.5" W x 15.5" H

BC.HTA.00.306.1000

\$229⁹⁹



Exterior bungee tie-downs

Reflective paneling

4-point soft-tie strap system



Tentbag secured to Cargobag (Tentbag sold separately, see page 142).



Forward carry handle



Durable metal buckles



Fits on:
 - All rear seats

Not recommended for use with rear luggage racks or sissy bar racks.

This bag can accommodate a full-face helmet plus other gear.

Elastic loops safely stow any excess strap length



NEW
features
for 2012

Racepack

- Includes instructions, waterproof inner bag, 4 mounting straps, 2 license plate fittings, shoulder strap, and tank-protection film.
- 2 separate outer compartments and 1 main compartment
- Integrated Tentbag tie-down points (see page 142 for information on the Tentbag)

Volume: 50-65 liters
Dimensions: 27.5" L x 12" W x 12"H

BC.HTA.00.302.1000

\$324⁹⁹

Shoulder strap attachment points double as tie-down points for extra gear

Reflective paneling

4-point soft-tie strap system

Zipper keeper (on both exterior pockets)



Tentbag secured to Racepack (Tentbag sold separately, see page 142).



Exterior compartment, durable metal eyelets, and reflective panels



Inner removable dry bag liner



Fits on:
- All rear seats

Not recommended for use with rear luggage racks or sissy bar racks.

Capacity:
This bag can accommodate a helmet and other gear.

Tentbag tie-down points

Elastic loops safely stow any excess strap length

Metal rings guide straps away from paint, helping to keep your bike blemish free.



Speedpack & Speedpack Wide

- Includes 3-part luggage system with inner bags, 4 mounting straps, 2 compression straps, 2 support straps for license plate installation, scratch resistant adhesive film, and shoulder carry strap.
- **Original Speedpack** fits bikes with a tail-section width of up to approximately 8.3"
- **Speedpack Wide** fits bikes with a tail-section width of approximately 16.4"
- Detachable side bags
- Self-supporting construction
- Waterproof outer material
- Waterproof liner bags included
- Stable 4-point attachment system
- Integrated Tentbag tie-down points (see page 142 for information on the Tentbag)
- Retroreflective piping for nighttime visibility

Volume: 85 to 100 liters

BCK.SP4001 **Speedpack Original**
 BCK.SP5001 **Speedpack Wide**

Your Choice!
\$325⁰⁰

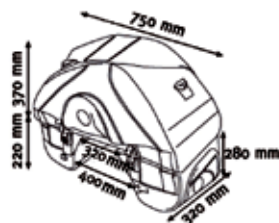

Speedpack Original

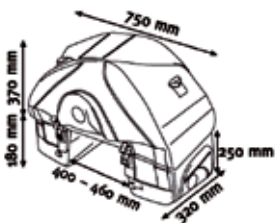

Speedpack Wide



Nemo Morpho 1P™ tent, Cosmo™ sleeping pad, and Fillo™ pillow fit in side pockets of Speedpack & Speedpack-Wide. See page 154 for details!

D-Rings bolt to license plate mounts



D-rings keep straps from scratching paint



Tentbag secured to Speedpack (Tentbag sold separately, see page 142).



Speedpack Wide: Compression straps applied.



Speedpack Wide: Expanded volume (100 liters).



NEW
features
for 2012

Tentbag

- Zipper opening located on the underside of bag.
- Attaches to Racepack, Speedpack, and Cargobag (sold separately) with these rearbag's included compression straps.
- Can be attached to any non Bags-Connection luggage by using ROK Straps (see page 149).

Volume: 22 liters
Dimensions: 22" L x 8" Dia.

BC.HTA.00.350.1000

\$54⁹⁹



Tentbag secured to the Cargobag



Tentbag secured to the Speedpack



Has handles at both ends



Tentbag secured to the Racepack



Rackpack

- Large enough for one full face helmet and a change of clothes
- 2 outer compartments and 1 main compartment
- Waterproof inner bag
- Includes shoulder carry strap
- Reflective piping for night time visibility
- Four ways to attach it to your bike:
 - Four tie-down straps for your rear luggage rack
 - Sissybar strap for cruisers
 - Underseat strap for sport bikes
 - Soft Luggage Carriers GPT.00.152.430 for ALU-RACKS, R1200GS Soft Luggage Carrier (GPB.07.710.10000.S)

Volume: 38 to 45 liters
 Dimensions: 17" L x 11.5" W x 11"H

BC.HTA.00.042.1010

\$139⁹⁹



Secured by a hook and loop sissy bar strap



Secured by an underseat strap



Inner dry bag liner



Honda 919

- Fits on:
- All rear seats
 - Larger rear luggage racks
 - Most sissy bar racks
 - The Soft Luggage Adapter for ALU-RACKS

Not recommended for use with a sissy bar where a rear rack is not present.

SW-MOTECH ALU-RACK GPT.01.131.100.B
 Soft Luggage Carrier GPT.00.152.430,
 and Rackpack II BC.HTA.00.042.1010



Bags-Connection Dry Bags are made from waterproof welded tarpaulin PVC. Even when sitting in a puddle, your stuff stays dry! The 35-liter size works well as a stand-alone rear bag. The larger 60-liter size works well placed across the rear seat and panniers or lengthwise covering the rear seat and luggage rack.

Dry Bag Features:

- Stable 4-point tie-down system.
- Available in two sizes: 60 and 35 liters.
- Includes 4 mounting straps and a shoulder strap.
- Fits nearly all sport, sport-touring, enduro, or cruiser motorcycles and scooters.

60-liter Dry Bag

27.5" long x 13" diameter
BCK.HTA.00.047.100



\$119⁹⁹

35-liter Dry Bag

21.7" long x 9.8" diameter
BCK.HTA.00.053.100

\$99⁹⁹

Fits on:

- Most rear seats and rear luggage racks.

Not recommended for use behind a sissy bar, with or without a rear luggage rack.



35-liter Dry Bag



35-liter Dry Bag mounted for single track



60-liter Dry Bag mounted across rear seat



60-liter Dry Bag mounted for single track





Bags-Connection High-Viz Dry Bags

have the same waterproof features as the black dry bags, but with the addition of conspicuity. It's a smart way to stay visible to drivers while keeping your stuff dry during even the mightiest of downpours.

60-liter Dry Bag

27.5" long x 13" diameter
BCK.HTA.00.47.10.Y

\$119⁹⁹



35-liter Dry Bag

21.7" long x 9.8" diameter
BCK.HTA.00.53.10.Y

\$99⁹⁹

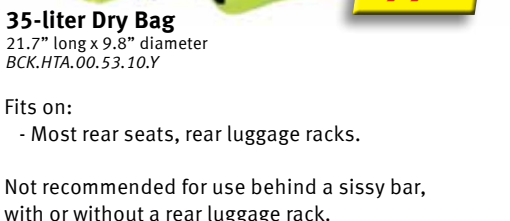

Fits on:

- Most rear seats, rear luggage racks.

Not recommended for use behind a sissy bar, with or without a rear luggage rack.



35-liter Dry Bag



35-liter Dry Bag mounted for single track



60-liter Dry Bag mounted across rear seat



60-liter Dry Bag mounted for single track

Baracuda Waterproof Backpack

- Made from welded waterproof PVC.
- 25-liter volume.
- Retroreflective trim.
- Interior pockets for pens, CDs, etc.
- Easy-lock shoulder strap detaches on right side using a Fastex connector, making it easy to put on the backpack when wearing a stiff armored motorcycle jacket.
- Molded back cushions provide comfort as well as air channels to keep your back cool in the summer.
- Chest and waist straps connect the shoulder straps to help carry the load, keeping you comfortable.
- Padded interior sleeve fits up to a 17" laptop computer.

\$139⁹⁹

BCK.WPB.00.056.100



Top waterproof seal rolls closed

Fits 17" laptop inside



Inspired by military tactical gear, DrySpec™ Dry Bags are the toughest and most versatile motorcycle dry bags on the planet. DrySpec Dry Bags come in two configurations; the D28 “Dual-end” Dry Bag and the D38 “Rigid” Dry Bag. Save some money by buying both bags at the same time with the D66 Dry Bag Modular Packing System.

Starting At
\$69⁹⁹



See the video!

DrySpec D28 Dual-End Dry Bag

The DrySpec™ D28 Dual-End Dry Bag is constructed of RF welded 18 oz. vinyl that guarantees 100% waterproof performance even when submersed. Unlike other dry bags, the D28 features a dual-end roll design that allows access to belongings from either end of the bag. No need to disconnect the mounting straps. Simply select the end you want to access, release the two securing clips, unroll, grab, re-roll, secure the clips, and go.

A 4-point Quick Connect Soft-Tie Strap and Daisy-Chain Mounting System is used to attach the bag to the motorcycle. Not only does this allow quick and easy mounting and removal, but also prevents load shifting for exceptional security. The D28 adapts to the shape of the contents you put inside, whether that is a sleeping bag, clothing or a laptop computer.

The D28 can be used on motorcycles with or without a luggage rack. You can mount the D28 parallel to the direction of travel or perpendicular across the passenger seat. You can even mount the D28 on top of existing side cases. However you choose to mount the D28, rest assured that your stuff will remain secure and dry.



Specifications:

- 100% Waterproof
- 9" wide x 9" tall x 22" long (average packed dimensions)
- 28 Liter capacity

\$69⁹⁹

DSL.D28.10000

Fits on:

- Most rear seats, rear luggage racks, or sissy bar racks.
- Not for use unsupported behind a sissy bar.



Get creative! Use the D28 as an expansion bag for your sidecases.



The D28's exterior daisy chain can be used to strap on a NEMO Morpho 2P Tent (see page 154).



D28 and included straps

DrySpec D38 Rigid Core Dry Bag



See the video!

Unlike other dry bags, the **D38 Rigid Core dry bag** features a rigid structure, which means that the bag functions more like a topcase than a traditional dry bag. You can mount the D38 onto any motorcycle with or without a rear rack. The D38 can be mounted even when the bag is completely empty. Try that with a traditional dry bag!

The rigid construction and unique 4-point Slip-Lock Strap mounting system allow access without loosening straps or removing the bag from the bike. Another feature of the DrySpec D38 is the Contour Roll Top Seal that rolls down to a fixed point with no excess material from the end of the roll. This ensures a clean look and a perfect waterproof seal.

Included is a 4-in-1 Utility Strap that acts as a compression strap to help compact your contents, a shoulder strap, a carrying handle, and a cargo strap to fasten additional gear on top.



The rigid core makes this empty D38 function like a topcase.

Specifications:

- Measures 13" wide x 9" tall x 22" long
- 38 Liter capacity
- Daisy-chain

\$129⁹⁹

DSL.D38.10000



D38 and included straps



The D38's Slip Lock Strap System makes securing the bag to your bike quick and very easy.



The 4-in-1 Utility Strap being used to secure a Nemo 2P (see page 154).

DrySpec D66 Dry Bag Modular Packing System

Enjoy \$20.00 savings when purchasing the D28 and D38 together as the D66 dry bag system. Combining the D38 and the D28 creates 66 liters of waterproof storage. The modular design allows secure, quick, and easy mounting of the D28 onto the D38 dry bag using Quick Connect Soft-Tie Straps and Daisy-Chain Mounting Systems.



\$179⁹⁹

DSL.D66.10000.B

The rigid core of the D38 allows mounting on bikes with a narrow tail section or seat.

The D38's rigid core allows the bag to be used across or parallel to the rear seat or luggage rack. It's even stiff enough to use as a backrest!



Soft Luggage Carriers

QUICK-LOCK Soft Luggage Carrier for SW-MOTECH ALU-RACKs

Removable quick-release adapter plate for mounting soft luggage or enlarging the surface area of the SW-MOTECH ALU-Racks. This adapter plate provides lots of possibilities for attaching tie-down straps to different points on the rack. Attaches/detaches in seconds using three quarter-turn fasteners.



Dimensions:
 - Depth: 10"
 - Front width: 15.5"
 - Rear width: 13"



ALU-Rack required (See page 82-83).



Mount Soft Luggage Carrier to ALU-Rack.



Rackpack II attached to Soft Luggage Carrier (see page 143).

GPT.00.152.430 \$53.00

GPB.07.710.10000.S (BMW R1200GS) \$79.99

Expansion Rack for SW-MOTECH Steel Topracks

Sliding expansion plate for mounting soft luggage or enlarging the surface area of a SW-MOTECH Steel Toprack. Create a large surface for luggage, or retract for a clean look when not carrying luggage.

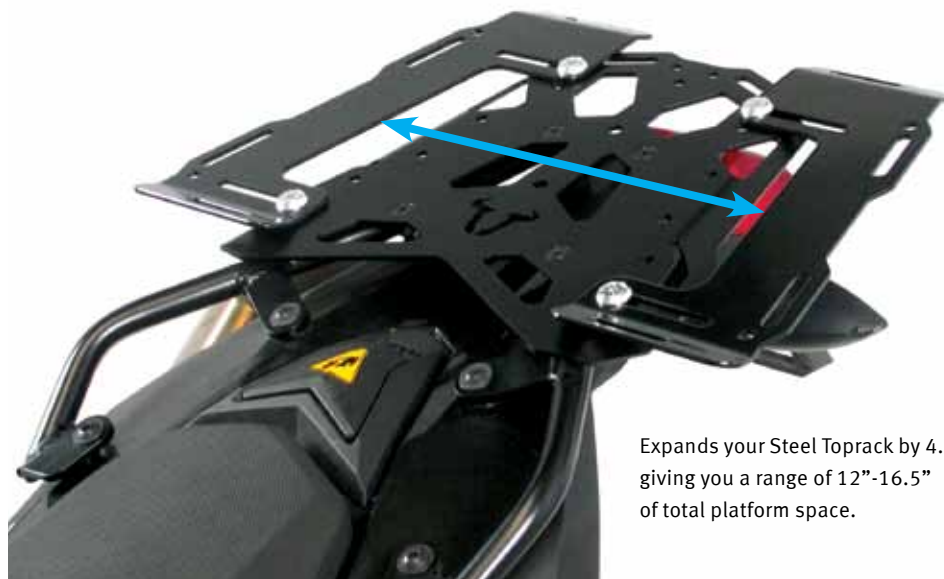

Expands your Steel Toprack by 4.5" giving you a range of 12"-16.5" of total platform space.

GPA.00.804.10000.B \$54.99

- Secure 4 bolt installation.
- Easily widen your original Steel Toprack platform by up to 4.5"

- Loosen 4 attachment bolts to slide the wings inward or outward as needed for your luggage.
- Use it to attach Soft luggage to an SW-MOTECH Steel Toprack.



Steel Toprack required (see page 80-81).



Retracted Mounted Expansion Rack.



NEMO Morpho 2P Tent strapped to the Expansion Rack (see page 154).



Bags-Connection Zipper Lock

- The Bags-Connection Zipper Lock is ideal for securing the contents of any rear bag or Aero sidecase. Not for use with Bags-Connection tankbags.
- Ultra-compact design makes these locks easy to carry.
- Simply pull through any compatible zipper pulls and engage the lock.
- Reprogrammable combination.

BCK.LOC.00.001.001: \$7.50

Cable lock securing Backpack



50cm (19.7") long: **\$13.49**

100cm (39.4") long: **\$15.99**

BC.LOC.00

Cable lock securing Tankbag



Bags-Connection Cable Lock

- The Bags-Connection cable lock is ideal for securing tankbags and rear bags to the bike.
- Simply loop the combination end around the frame of the bike and through the loop on the other end of the cable and attach it to the bag's zipper pull and/or D-rings.
- Reprogrammable combination lock.



STA.HG.B: **\$51.95**

Helmet Guardian locking 2 helmets



Helmet Guardian

- Easy to install on either the upper or lower license plate bolts.
- Consists of two high quality, spring-loaded helmet locks attached to a steel plate that is pre-drilled with slots ready to attach to most US and Canadian license plates.
- Powder coated black
- 11" W x 2.5" L



Bungee Net

Easy to use, strong elasticized bungee net.

- 6 nylon-coated steel hooks.
- 17" x 17"
- Great for transporting bulky, lightweight items that don't easily fit inside your luggage.

OXF.OF1.77: **\$9.99**

Adjustable Motorcycle ROK Straps

These "flat stretch straps" are designed specifically for motorcycles, ATV's, and snowmobiles. The soft-loop design allows you to secure the straps without scratching your motorcycle. Loops on both ends can be secured to just about anything, while the mid-strap buckle allows you to tighten the strap to your needs. There are two strap styles available:

"**Motorcycle Straps**" are the strongest, most durable ROK Straps. Use them for securing larger luggage to your bike.

"**Pack Straps**" are thinner and are designed for smaller, lighter items like sleeping bags and tents.



Item	Description	Item No.	Price
Motorcycle Straps, black w/stripes	54" x 1"	ROK.00001	\$21.95
Pack Strap, black	42" x 5/8"	ROK.00308	\$9.95

Soft Luggage Application Chart

This application chart lists confirmed applications for tankbags and rear bags. "X" signifies compatibility, "-" signifies non-fit. The "Ring" column refers to the last digits of the product number for the appropriate tankring. See page 156-227 for bike-specific tankring applications

					Micro	Daypack	Engage	Trial	Sport	City	GS	Enduro	Enduro LT	Cargobag	Racepack	Rearbag	Speedpack	Slipstream	Jetpack	Rackpack	Dry Bag	DrySpec	
				QUICK-LOCK Tankbags	Strap			Rear Bags								Dry Bags							
Aprilia	From	To	Ring																				
ETV1000 Caponord	'01	'07	175	X	X	X	X	-	X	-	X	X	X	X	-	X	-	X	-	X	-	X	X
Dorsoduro 750	'09	'10	N/A	-	-	-	-	-	-	-	-	X	X	-	-	-	-	-	-	-	-	X	-
SL 750 Shiver	'08	'12	175	-	-	-	-	-	-	-	-	-	-	X	-	X	-	X	-	X	-	X	X
SXV450	'08	'12	175	-	-	-	X	-	-	-	-	-	-	X	-	X	X	X	-	-	-	X	X
Pegaso 650	'05	'07	175	-	-	-	X	-	-	-	-	X	X	X	-	X	-	X	-	-	-	X	X
RSV1000R Factory	'06	'06	N/A	-	-	-	-	-	-	-	-	-	-	X	-	X	-	X	-	-	-	X	X
RSV1000R	'03	'03	175	X	X	-	-	-	-	-	-	-	-	X	-	X	X	X	-	X	-	X	X
RSV1000R	'04	'05	175	X	X	-	-	-	-	-	-	-	-	X	-	X	-	X	-	X	-	X	X
RSV1000R	'06	'12	N/A	-	-	-	-	-	-	-	-	-	-	-	-	-	-	-	-	-	X	-	-
Tuono 1000R	'03	'05	175	X	X	-	-	-	-	-	-	-	-	X	-	X	-	X	-	X	-	X	X
Tuono 1000R	'06	'12	N/A	-	-	-	-	-	-	-	-	-	-	X	-	X	-	X	-	X	-	X	X
BMW	From	To	Ring	QUICK-LOCK Tankbags				Strap			Rear Bags								Dry Bags				
F650 Funduro & F650 ST	'93	'00	118	X	X	X	-	-	-	-	-	-	-	X	-	X	-	X	-	X	-	X	X
F650CS Scarver	'02	'06	TWT	X	X	X	-	-	-	-	-	X	X	X	X	X	X	X	-	X	-	X	X
F650GS & F650GS Dakar	'00	'07	TWT	X	X	X	-	-	X	X	X	X	X	X	-	X	-	X	-	X	-	X	X
F650GS & F800GS	'08	'12	TWT	X	X	X	-	-	X	X	X	X	X	X	-	X	-	X	-	X	-	X	X
F800R	'09	'12	TWT	X	X	-	-	-	-	-	-	X	X	X	-	X	-	X	-	X	-	X	X
F800S & F800ST	'06	'12	TWT	X	X	X	-	-	-	-	-	X	X	X	-	X	-	X	-	X	-	X	X
G450X	'09	'11	N/A	-	-	-	-	-	-	-	-	X	X	-	X	-	X	-	X	-	X	-	X
G650 Xchallenge, Xcountry, Xmoto	'07	'09	N/A	-	-	-	-	-	-	-	-	X	X	-	X	-	X	-	X	-	X	-	X
G650GS	'09	'12	TWT	X	X	X	-	-	X	X	-	-	-	X	-	X	-	X	-	X	-	X	X
G650GS Sertao	12	'12	TWT	X	X	X	-	-	X	X	-	-	-	X	-	X	-	X	-	X	-	X	X
HP2 Enduro & HP2 Megamoto	'06	'08	120	X	X	-	-	-	-	-	-	-	-	-	-	-	-	-	-	-	-	-	-
HP2 Sport	'08	'08	124	X	X	-	-	-	-	-	-	-	-	-	-	-	-	-	-	-	-	-	-
HP2 Sport	'09	'10	12700	X	X	-	-	-	-	-	-	-	-	-	-	-	-	-	-	-	-	-	-
K1200GT	'03	'05	120	X	X	X	-	-	-	-	-	-	-	X	-	X	-	X	-	X	-	X	X
K1200GT	'06	'08	120	X	X	X	-	-	-	-	-	-	-	-	-	-	-	-	-	-	X	-	-
K1200R	'05	'08	120	X	X	X	-	-	-	-	-	-	-	X	-	X	-	X	-	X	-	X	X
K1200RS	'97	'08	120	X	X	X	-	-	-	-	-	-	-	X	-	X	-	X	-	X	-	X	X
K1200S	'05	'08	120	X	X	X	-	-	-	-	-	-	-	X	-	X	-	X	-	X	-	X	X
K1300GT	'09	'12	126	X	X	-	-	-	-	-	-	-	-	X	-	X	-	X	-	X	-	X	X
K1300R	'09	'12	126	X	X	-	-	-	-	-	-	-	-	X	-	X	-	X	-	X	-	X	X
K1300S	'09	'12	126	X	X	-	X	-	-	-	-	-	-	X	-	X	-	X	-	X	-	X	X
K1600GT, K1600GTL	'11	'12	*D	-	-	-	X	-	-	-	-	-	-	X	-	X	-	X	-	X	-	X	X
R1100GS	'94	'99	120	X	X	X	-	-	X	X	X	X	-	-	-	-	-	-	-	-	X	-	-
R1100R	'95	'99	120	X	X	X	-	-	-	-	-	-	-	-	-	-	-	-	-	-	-	-	-
R1100RS	'93	'06	120	X	X	X	-	-	-	-	-	-	-	-	-	-	-	-	-	-	X	-	-
R1100RT	'96	'00	120	X	X	X	-	-	-	-	-	-	-	-	-	-	-	-	-	-	-	-	-
R1100S	'97	'05	120	X	X	X	-	-	-	-	-	-	-	X	X	X	X	X	-	X	-	X	X
R1150GS	'99	'04	120	X	X	X	-	-	X	X	X	X	X	X	-	X	X	X	-	X	-	X	X
R1150GS Adventure	'01	'05	120	-	-	-	-	-	-	-	-	X	X	X	-	X	X	X	-	X	-	X	X
R1150R	'00	'06	120	X	X	X	-	-	-	-	-	-	-	X	X	X	-	X	-	X	-	X	X
R1150R Rockster	'04	'05	120	X	X	X	-	-	-	-	-	-	-	-	-	-	-	-	-	-	-	-	-
R1150RS	'01	'05	120	X	X	X	-	-	-	-	-	-	-	X	X	X	X	X	-	X	-	X	X
R1150RT	'00	'04	120	X	X	X	-	-	-	-	-	-	-	-	X	X	X	X	-	X	-	X	X
R1200C	'97	'04	N/A	-	-	-	X	-	-	-	-	-	-	-	-	-	-	-	-	-	-	-	-
R1200CL	'02	'04	N/A	-	-	-	X	-	-	-	-	-	-	-	-	-	-	-	-	-	-	-	-
R1200GS w/o handlebar mounted stereo	'04	'07	120	X	X	X	X	-	X	X	X	X	X	X	-	X	-	X	-	X	-	X	X
R1200GS	'08	'08	124	X	X	X	X	-	X	X	X	X	X	X	-	X	-	X	-	X	-	X	X
R1200GS	'09	'12	12700	X	X	X	X	-	X	X	X	X	X	X	-	X	-	X	-	X	-	X	X
R1200GS Adventure w/ OEM crossbar removed	'06	'07	120	X	X	X	-	-	X	X	X	X	X	-	X	X	-	X	-	X	-	X	X
R1200GS Adventure	'08	'08	124	X	X	X	-	-	X	X	X	X	X	-	X	X	-	X	-	X	-	X	X
R1200GS Adventure	'09	'12	12700	X	X	X	-	-	X	X	X	X	X	X	-	X	-	X	-	X	-	X	X
R1200R	'06	'08	123	X	X	X	-	-	-	-	-	-	-	X	X	X	X	X	-	X	-	X	X
R1200R	'09	'12	12800	X	X	X	-	-	-	-	-	-	-	X	X	X	X	X	-	X	-	X	X
R1200RT	'05	'12	122	X	X	-	-	-	X	-	-	-	-	X	-	X	-	X	-	X	-	X	X
R1200S	'06	'08	124	X	X	X	-	-	-	-	-	-	-	X	X	X	X	X	-	X	-	X	X
R1200S	'09	'11	12700	X	X	X	-	-	-	-	-	-	-	X	X	X	X	X	-	X	-	X	X
R1200ST	'05	'12	122	X	X	X	-	-	-	-	-	-	-	X	-	X	-	X	-	X	-	X	X
R850R	'99	'06	120	-	-	-	-	-	-	-	-	-	-	X	X	X	X	X	-	X	-	X	X
S1000RR	'10	'12	127	X	X	-	-	-	-	-	-	-	-	-	-	-	-	X	-	-	-	-	-
Buell	From	To	Ring	QUICK-LOCK Tankbags				Strap			Rear Bags								Dry Bags				
1125R	'08	'10	TWT	X	X	X	-	-	X	-	-	-	-	-	-	-	-	-	-	-	-	-	-
Firebolt XB12R	'09	'10	TWT	X	X	X	-	-	X	-	-	-	-	X	X	X	-	X	-	X	-	X	X
Firebolt XB9R	'09	'10	TWT	X	X	X	-	-	X	-	-	-	-	X	X	X	-	X	-	X	-	X	X
Lightning Super TT XB12STT	'09	'10	TWT	X	X	X	-	-	X	-	-	-	-	-	-	-	-	-	-	-	-	-	-
Lightning XB12S & XB12Scg	'09	'10	TWT	X	X	X	-	-	X	-	-	-	-	X	-	-	-	-	-	-	-	-	-
Ulysses XB12X	'05	'10	TWT	X	X	X	-	-	X	-	-	-	-	-	X	X	-	X	-	X	-	X	X
Ulysses XB12XT	'10	'10	TWT	X	X	X	-	-	X	-	-	-	-	-	-	-	-	-	-	X	-	-	-
Can-am	From	To	Ring	QUICK-LOCK Tankbags				Strap			Rear Bags								Dry Bags				
Spyder Roadster	'08	'12	N/A	-	-	-	-	-	-	-	-	-	-	X	-	X	-	X	-	-	-	X	X
Ducati	From	To	Ring	QUICK-LOCK Tankbags				Strap			Rear Bags								Dry Bags				
748	'94	'02	110	X	X	X	-	-	X	-	-	-	-	-	-	X	X	-	-	-	X	-	-
749	'03	'06	110	X	X	X	-																

Soft Luggage Application Chart

This application chart lists confirmed applications for tankbags and rear bags. "X" signifies compatibility, "-" signifies non-fit. The "Ring" column refers to the last digits of the product number for the appropriate tanking. See page 156-227 for bike-specific tankring applications

	Micro	Daypack	Engage	Trial	Sport	City	GS	Enduro	Enduro LT	Cargobag	Racepack	Rearbag	Speedpack	Slipstream	Jetpack	Rackpack	Dry Bag	DrySpec
Ducati (cont.)	From	To	Ring	QUICK-LOCK Tankbags				Strap	Rear Bags						Dry Bags			
996	'00	'01	110	X	X	X	-	-	X	-	-	-	X	X	-	-	X	-
998	'02	'03	110	X	X	X	-	-	X	-	-	-	-	-	-	-	-	-
999	'03	'06	N/A	-	-	-	-	-	-	-	-	-	-	-	-	X	-	-
1098, 109R, 1198, & 1198R, Streetfighter	'07	'11	110	X	X	X	-	-	X	-	-	-	-	-	-	X	-	-
Monster 1000	'03	'05	110	X	X	X	X	X	-	-	-	X	X	X	-	-	X	-
Monster 1000s	'03	'05	110	X	X	X	X	X	-	-	-	-	-	-	-	-	-	-
Monster 620 & 620 Dark	'02	'06	110	X	X	X	X	X	-	-	-	X	X	X	-	-	X	-
Monster S2R & S2R Dark	'05	'07	110	X	X	X	X	X	1	-	-	-	X	X	X	-	-	X
Monster S4R	'03	'11	110	X	X	X	X	X	1	-	-	-	X	X	X	-	-	X
Monster S4	'00	'02	110	X	X	X	X	X	-	-	-	X	X	X	-	-	X	-
Multistrada DS1000	'03	'06	N/A	-	-	-	-	-	-	-	-	-	-	-	-	X	X	-
Multistrada DS620	'05	'06	N/A	-	-	-	-	-	-	-	-	-	-	-	-	X	X	-
Multistrada DS1100	'07	'10	N/A	-	-	-	-	-	-	-	-	-	-	-	-	X	X	-
Multistrada 1200	'10	'11	126	-	-	-	-	-	-	-	-	-	-	-	-	X	X	-
ST2	'03	'03	110	X	X	X	-	-	X	-	-	-	-	-	-	-	-	-
ST3	'04	'09	110	X	X	X	-	-	X	-	-	-	X	-	-	-	X	-
ST4	'01	'05	110	X	X	X	-	-	X	-	-	-	X	-	-	-	X	-
Super Sport SS 750	'01	'02	110	X	X	X	-	-	X	-	-	-	-	-	-	-	-	-
Super Sport SS 900	'01	'02	110	X	X	X	-	-	X	-	-	-	-	-	-	-	-	-
Super Sport SS 1000 DS	'03	'06	110	X	X	X	-	-	X	-	-	-	-	-	-	-	X	-
Harley-Davidson	From	To	Ring	QUICK-LOCK Tankbags				Strap	Rear Bags						Dry Bags			
XL 883 Sportster	'04	'04	N/A	-	-	-	-	-	-	-	X	X	X	-	X	-	X	X
XL 883C Sportster Custom	'04	'04	N/A	-	-	-	-	-	-	-	X	X	X	-	X	-	X	X
FXD Dyna Super Glide	'04	'04	N/A	-	-	-	-	-	-	-	X	X	X	-	X	-	X	X
FXDX Dyna Super Glide Sport	'04	'04	N/A	-	-	-	-	-	-	-	X	X	X	-	X	-	X	X
FXDL Dyna Low Rider	'04	'04	N/A	-	-	-	-	-	-	-	X	X	X	-	X	-	X	X
FXDWG Dyna Wide Glide	'04	'04	N/A	-	-	-	-	-	-	-	X	X	X	-	X	-	X	X
Softail Standard FXST/FXSTI	'04	'04	N/A	-	-	-	-	-	-	-	X	X	X	X	X	-	X	X
V-Rod	'04	'04	N/A	-	-	-	-	-	-	-	X	X	X	-	X	-	X	X
Honda	From	To	Ring	QUICK-LOCK Tankbags				Strap	Rear Bags						Dry Bags			
599	'04	'06	106	X	X	-	-	X	-	-	-	X	X	X	-	X	-	X
919	'00	'07	106	X	X	-	-	X	-	-	-	X	X	X	-	X	-	X
CB1000R	'08	'12	106	X	X	-	-	-	-	-	-	-	-	-	X	-	X	-
CBF1000	'10	'12	106	X	X	-	-	-	-	-	-	-	-	-	X	-	X	-
CBR250	'11	'12	N/A	-	-	-	-	-	-	-	-	-	-	-	-	X	-	-
CBR1000RR Fireblade	'04	'07	106	X	X	-	-	X	-	-	-	X	-	X	-	X	-	X
CBR1000RR Fireblade	'08	'12	106	X	X	-	-	X	-	-	-	X	X	X	X	-	X	X
CBR1100XX Blackbird	'96	'07	106	X	X	-	-	X	-	-	-	X	X	X	X	-	X	X
CBR600F4i	'01	'06	106	X	X	-	-	X	-	-	-	X	X	X	X	-	X	X
CBR600RR	'03	'12	106	X	X	-	-	X	-	-	-	X	X	X	X	-	X	X
CBR900RR	'93	'01	106	X	X	X	-	X	-	-	-	X	X	X	X	-	X	X
CBR929	'00	'01	106	X	X	X	-	-	-	-	-	-	-	-	-	-	X	-
CBR954	'02	'04	106	X	X	X	-	-	-	-	-	-	-	-	-	-	X	-
CMX250C Rebel	'99	'12	N/A	-	-	-	-	-	-	-	-	X	-	X	-	-	-	-
Goldwing GL1800	'01	'12	N/A	-	-	-	-	-	-	-	-	-	-	-	-	-	-	-
NT700 Deauville	'08	'11	N/A	-	-	-	-	-	-	-	-	X	-	X	-	X	-	X
ST1100 Pan European	'90	'02	N/A	-	-	-	-	-	-	-	-	-	-	-	-	X	-	-
ST1300 Pan European	'03	'12	106	X	X	X	X	1	-	-	-	X	-	X	-	X	-	X
VFR800	'98	'01	106	X	X	-	-	X	-	-	-	X	3	X	3	X	-	X
VFR800 VTEC	'02	'11	106	X	X	-	-	X	-	-	-	X	-	X	-	X	-	X
VT600C Shadow VLX	'91	'05	N/A	-	-	-	-	-	-	-	-	-	-	-	-	-	X	-
VT600CD Shadow VLX Deluxe	'91	'05	N/A	-	-	-	-	-	-	-	-	-	-	-	-	-	X	-
VT750C Shadow Aero	'04	'08	N/A	-	-	-	-	-	-	-	-	-	-	-	X	-	X	-
VT750C2 Shadow Spirit	'07	'08	N/A	-	-	-	-	-	-	-	-	-	-	X	-	X	-	-
VT750DC Black Widow / Shadow Spirit 750	'00	'07	N/A	-	-	-	-	-	-	-	-	-	-	X	-	-	X	-
VTR1000F Superhawk	'97	'06	106	X	X	-	-	-	-	-	-	X	X	X	X	X	-	X
VTR1000SP1 Firestorm	'97	'06	106	X	X	-	-	-	-	-	-	X	X	X	X	X	-	X
VTR1000SP2 RC51	'97	'06	106	X	X	X	-	-	-	-	-	X	X	X	X	X	-	X
VFR1200	'10	'12	106	X	X	X	-	-	X	-	-	X	-	X	-	-	X	-
VTX1300 & VTX1800	'03	'12	N/A	-	-	-	-	-	-	-	-	-	-	X	-	-	X	-
XL1000V Varadero	'08	'12	106	X	X	-	-	X	X	X	X	-	-	-	-	-	X	-
XL650V Transalp	'00	'06	106	-	-	-	-	-	X	X	X	-	X	-	X	-	X	X
XL700V Transalp	'08	'10	106	X	X	-	-	-	X	-	-	X	-	X	-	X	-	X
XR650L & XR650R	'93	'12	N/A	-	-	-	-	-	-	-	-	X	-	X	X	X	-	X
Kawasaki	From	To	Ring	QUICK-LOCK Tankbags				Strap	Rear Bags						Dry Bags			
Concours GTR1000 / ZG1000	'86	'07	135	X	X	X	X	-	-	-	-	-	-	-	-	-	X	-
Concours GTR1400	'08	'12	GTR	X	X	X	-	-	-	-	-	X	-	X	-	X	-	X
KLR650A	'86	'07	N/A	-	-	-	-	-	X	X	X	-	X	-	X	-	X	X
KLR650E	'08	12	N/A	-	-	-	-	-	X	X	X	-	-	-	-	-	X	-
KLX250S	'06	12	N/A	-	-	-	-	-	-	-	-	X	-	X	X	X	-	X
Ninja 250R / EX250 / ZZR250	'88	'07	135	X	X	-	-	X	-	-	-	-	-	-	-	-	X	-
Ninja 250R	'08	12	116	X	X	-	-	-	-	-	-	-	-	-	-	-	X	-
Ninja 500R / EX500S / GPZ500S	'87	'09	135	X	X	-	-	X	-	-	-	-	-	-	-	-	X	-
Ninja 650R / ER6F / ER6N	'06	'08	140	X	X	-	-	-	X	-	-	-	-	-	-	-	X	-
Ninja 650R / ER6F / ER6N	'09	'12	140	X	X	-	-	-	X	-	-	X	-	X	-	X	-	X

Soft Luggage Application Chart

This application chart lists confirmed applications for tankbags and rear bags. “X” signifies compatibility, “-” signifies non-fit. The “Ring” column refers to the last digits of the product number for the appropriate tankring. See page 156-227 for bike-specific tankring applications

				Micro	Daypack	Engage	Trial	Sport	City	GS	Enduro	Enduro LT	Cargobag	Racepack	Rearbag	Speedpack	Slipstream	Jetpack	Rackpack	Dry Bag	DrySpec	
Kawasaki (cont.)					QUICK-LOCK Tankbags												Strap	Rear Bags			Dry Bags	
Ninja 1000	'11	'12	*D	X	X	-	-	-	-	-	-	-	X	X	-	X	-	X	-	X	X	X
Versys 650	'07	'12	140	X	X	-	-	-	X	-	-	-	X	-	X	-	X	-	X	-	X	X
VN1500 Vulcan Drifter	'01	'01	N/A	-	-	-	-	-	-	-	-	-	-	-	-	-	-	-	-	X	-	-
VN1600 Vulcan Classic	'01	'01	N/A	-	-	-	-	-	-	-	-	-	X	X	X	X	X	-	X	-	X	X
VN2000 Vulcan	'01	'01	N/A	-	-	-	-	-	-	-	-	-	X	X	X	X	X	-	X	-	X	X
VN800 Vulcan Classic	'01	'01	N/A	-	-	-	-	-	-	-	-	-	X	X	X	X	X	-	X	-	X	X
W650	'99	'07	N/A	-	-	-	-	-	-	-	-	-	X	X	X	X	X	-	X	-	X	X
Z1000	'03	'06	140	X	X	X	X	X	X	-	-	-	X	X	X	-	X	-	X	-	X	X
Z1000	'07	'09	140	X	X	-	-	-	X	-	-	-	X	-	X	-	X	-	X	-	X	X
Z1000	'10	'12	140	X	X	-	-	-	X	-	-	-	-	X	X	-	X	-	X	-	X	X
Z1000SX (Ninja 1000)	'11	'12	140	X	X	-	-	-	X	-	-	-	-	X	X	-	X	-	X	-	X	X
Z750	'04	'07	140	X	X	X	X	-	-	-	-	-	-	X	3	-	X	-	X	-	X	X
Z750S	'05	'07	140	X	X	X	X	X	-	-	-	-	-	X	3	-	X	-	X	-	X	X
ZR7	'00	'00	135	X	X	X	-	-	-	-	-	-	-	-	-	-	-	-	-	X	-	-
ZR7S	'01	'03	135	X	X	X	-	-	-	-	-	-	-	-	-	-	-	-	-	X	-	-
ZRX1100	'97	'00	140	X	X	-	-	-	X	-	-	-	X	X	X	X	X	-	X	-	X	X
ZRX1200R, ZRX1100	'01	'05	140	X	X	-	-	-	X	-	-	-	X	X	X	X	X	-	X	-	X	X
ZX10R Ninja	'04	'05	140	X	X	-	-	-	X	-	-	-	X	-	X	-	X	-	X	-	X	X
ZX10R Ninja	'06	'07	140	X	X	-	-	-	X	-	-	-	X	-	X	-	X	-	X	-	X	X
ZX10R Ninja	'08	'10	140	X	X	-	-	-	X	-	-	-	X	-	X	-	X	-	X	-	X	X
ZX10R Ninja	'11	'12	*D	X	X	-	-	-	X	-	-	-	-	-	-	-	X	-	X	-	X	-
ZX12R	'00	'05	N/A	-	-	-	-	-	-	-	-	-	X	X	X	-	X	-	X	-	X	X
ZX14 Ninja (a.k.a. ZZR1400)	'06	'12	140	X	X	-	-	-	X	-	-	-	-	-	X	-	X	-	X	-	X	X
ZX6 / ZZR600	'95	'00	135	X	X	-	-	-	X	-	-	-	-	-	-	-	-	-	-	X	-	-
ZX6R	'00	'02	140	X	X	-	-	-	-	-	-	-	X	-	X	-	X	-	X	-	X	X
ZX6R 636 Ninja	'05	'07	140	X	X	-	-	-	X	-	-	-	X	-	X	-	X	-	X	-	X	X
ZX6RR	'05	'07	140	X	X	-	-	-	X	-	-	-	X	-	X	-	X	-	X	-	X	X
ZX6R	'08	'12	140	X	X	-	-	-	X	-	-	-	X	-	X	-	X	-	X	-	X	X
ZX7R	'90	'02	140	X	X	-	-	-	X	-	-	-	X	X	X	X	X	-	X	-	X	X
ZX9R	'94	'03	135	X	X	-	-	-	X	-	-	-	-	-	-	-	-	-	-	X	-	-
ZZR1200	'03	'06	140	X	X	-	-	-	X	-	-	-	X	-	X	-	X	-	X	-	X	X
KTM				From	To	Ring	QUICK-LOCK Tankbags					Strap	Rear Bags			Dry Bags						
LC4 Adventure 640	'97	'07	N/A	-	-	-	-	-	-	-	X	X	-	X	X	-	X	-	X	-	X	X
LC4 Enduro	'08	'12	N/A	-	-	-	-	-	-	-	X	X	-	X	X	X	X	-	X	-	X	X
LC8 Adventure 950 & 950/S	'03	'06	N/A	-	-	-	-	-	-	-	X	X	-	X	X	X	X	-	X	-	X	X
LC8 Adventure 990 & 990	'06	'12	N/A	-	-	-	-	-	-	-	X	X	-	X	X	X	X	-	X	-	X	X
LC8 SuperEnduro 950	'03	'05	N/A	-	-	-	-	-	-	-	X	X	-	-	-	-	-	-	-	-	-	-
LC8 SuperMoto 950	'05	'12	N/A	-	-	-	-	-	-	-	X	X	-	-	X	-	X	-	-	-	X	X
SM690 Supermoto	'07	'12	N/A	-	-	-	-	-	-	-	X	X	-	-	X	-	X	-	-	-	X	X
Super Duke 990	'07	'12	170	X	X	-	-	-	-	-	X	X	-	-	-	-	-	-	-	-	-	-
Moto Guzzi				From	To	Ring	QUICK-LOCK Tankbags					Strap	Rear Bags			Dry Bags						
Breva 1100	'08	'11	N/A	-	-	-	-	-	-	-	-	-	-	X	-	X	-	-	X	-	-	-
Breva V750 IE	'08	'10	180	X	X	X	X	X	-	-	-	-	-	X	X	X	-	-	X	-	-	-
California EV	'01	'05	N/A	-	-	-	-	-	-	-	-	-	-	-	X	-	-	-	X	-	-	-
California EV Touring	'06	'07	180	X	X	X	-	-	-	-	-	-	-	-	-	-	-	-	X	-	-	-
Nevada Classic 750	'06	'11	180	X	X	X	-	-	-	-	-	-	-	-	-	X	-	-	X	-	-	-
V11 Scura	'98	'05	180	X	X	X	-	-	X	-	-	-	-	-	-	-	-	-	X	-	X	-
Stelvio 1200V	'08	'11	N/A	-	-	-	-	-	-	-	-	-	-	-	X	-	X	-	X	-	X	-
MV Agusta				From	To	Ring	QUICK-LOCK Tankbags					Strap	Rear Bags			Dry Bags						
F4-1000	'06	'06	195	X	X	-	-	-	-	-	-	-	-	-	-	-	-	-	-	-	-	-
F4 Senna	'06	'06	195	X	X	-	-	-	-	-	-	-	-	-	-	-	-	-	-	-	-	-
910 Brutale	'06	'06	195	X	X	-	-	-	-	-	-	-	-	-	-	-	-	-	-	-	-	-
Suzuki				From	To	Ring	QUICK-LOCK Tankbags					Strap	Rear Bags			Dry Bags						
Boulevard C50 / VL800 LC Intruder Volusia	'05	'12	N/A	-	-	-	-	-	-	-	-	-	X	X	-	X	-	-	X	-	-	-
Boulevard C90 / VL1500 LC Intruder Volusia	'98	'12	N/A	-	-	-	-	-	-	-	-	-	X	X	-	X	-	-	X	-	-	-
Boulevard M50 / VZ800 Marauder	'05	'12	N/A	-	-	-	-	-	-	-	-	-	-	X	X	-	X	-	X	-	-	-
Boulevard M95 / VZ1600 Marauder	'04	'12	N/A	-	-	-	-	-	-	-	-	-	-	X	X	-	X	-	X	-	-	-
Boulevard S50 / VS800 Intruder	'05	'12	N/A	-	-	-	-	-	-	-	-	-	-	X	X	-	X	-	X	-	-	-
Boulevard S83 / VS1400 Intruder	'87	'12	N/A	-	-	-	-	-	-	-	-	-	-	X	X	-	X	-	X	-	-	-
Boulevard S90 / VS1500 Intruder	'98	'04	N/A	-	-	-	-	-	-	-	-	-	-	X	X	-	X	-	X	-	-	-
DL1000 V-Strom	'02	'12	115	X	X	X	-	-	X	X	-	-	X	-	X	-	X	-	X	-	X	X
DL650 V-Strom	'04	'11	115	X	X	X	-	-	X	X	-	-	X	-	X	-	X	-	X	-	X	X
DL650 V-Strom	'12	'12	115	X	X	X	-	-	X	X	-	-	X	-	X	-	X	-	X	-	X	X
DR650SE	'96	'12	N/A	-	-	-	-	-	-	-	X	X	-	X	X	-	X	-	X	-	X	X
DRZ400S & DRZ400SM	'01	'12	N/A	-	-	-	-	-	-	-	X	X	-	X	X	X	X	-	X	-	X	X
GS500E	'89	'02	115	X	X	-	-	X	-	-	-	-	X	X	X	X	X	-	X	-	X	X
GS500F	'04	'12	115	X	X	-	-	X	-	-	-	-	X	X	X	X	X	-	X	-	X	X
GSF1200 Bandit	'97	'05	115	X	X	X	X	X	-	-	-	-	X	X	X	X	X	-	X	-	X	X
GSF1200 Bandit	'06	'06	125	X	X	X	X	-	-	-	-	-	X	X	X	X	X	-	X	-	X	X
GSF1250 Bandit	'07	'12	125	X	X	X	X	-	-	-	-	-	X	X	X	X	X	-	X	-	X	X
GSX120FA	'10	'12	125	X	X	X	X	-	-	-	-	-	X	X	X	X	X	-	X	-	X	X
GSF600 Bandit	'00	'04	115	X	X	X	X	-	-	-	-	-	X	X	X	X	X	-	X	-	X	X
GSF650 Bandit	'05	'12	125	X	X	X	X	-	-	-	-	-	X	X	X	X	X	-	X	-	X	X
GSX1300R Hayabusa	'99	'05	115	X	X	-	-	X	-	-	-	-	X	X	X	X	X	-	X	-	X	X

This application chart lists confirmed applications for tankbags and rear bags. "X" signifies compatibility, "-" signifies non-fit. The "Ring" column refers to the last digits of the product number for the appropriate tankring. See page 156-227 for bike-specific tankring applications

	Micro	Daypack	Engage	Trial	Sport	City	GS	Enduro	Enduro LT	Cargobag	Racepack	Rearbag	Speedpack	Slipstream	Jetpack	Backpack	Dry Bag	DrySpec			
Suzuki (cont.)																					
	From	To	Ring	QUICK-LOCK Tankbags				Strap	Rear Bags				Dry Bags								
GSX1340R Hayabusa	'08	12	125	X	X	-	-	X	-	-	-	X	X	X	X	-	X	X	X		
GSX1400	'01	'06	125	X	X	-	-	X	-	-	-	X	X	X	X	X	-	X	X	X	
GSX600F Katana	'98	'02	125	X	X	-	X	X	-	-	-	X	X	X	X	X	-	X	X	X	
GSX600F Katana	'03	'07	125	X	X	-	X	X	-	-	-	X	X	X	X	X	-	X	X	X	
GSX650F	'08	12	125	X	X	X	-	-	-	-	-	X	X	X	X	X	-	X	X	X	
GSX750F Katana	'98	'02	125	X	X	-	X	X	-	-	-	X	X	X	X	X	-	X	X	X	
GSX750F Katana	'03	'07	125	X	X	-	X	X	-	-	-	X	X	X	X	X	-	X	X	X	
GSXR1000	'00	'04	115	X	X	-	-	X	-	-	-	X	X	X	X	X	-	X	X	X	
GSXR1000	'05	12	125	X	X	-	-	X	-	-	-	X	-	X	-	X	-	X	X	X	
GSXR600	'00	'05	115	X	X	-	-	X	-	-	-	X	X	X	X	X	-	X	X	X	
GSXR600	'06	12	125	X	X	-	-	X	-	-	-	X	-	X	-	X	-	X	X	X	
GSXR750	'96	'05	115	X	X	-	-	X	-	-	-	X	X	X	X	X	-	X	X	X	
GSXR750	'06	'07	125	X	X	-	-	X	-	-	-	X	-	X	-	X	-	X	X	X	
GSXR750	'08	12	125	X	X	-	-	X	-	-	-	X	-	X	-	X	-	X	X	X	
SFV650 Gladius	'09	12	125	X	X	X	X	-	-	-	-	X	-	X	-	X	-	X	X	X	
SV1000 & SV1000S	'03	'05	125	X	X	X	-	X	-	-	-	X	X	X	X	X	-	X	X	X	
SV650N & SV650S	'99	12	115	X	X	X	-	X	-	-	-	X	X	X	X	X	-	X	X	X	
Triumph																					
	From	To	Ring	QUICK-LOCK Tankbags				Strap	Rear Bags				Dry Bags								
Bonneville America	'02	12	N/A	-	-	-	-	-	-	-	-	X	X	X	X	X	-	X	X	X	
Bonneville & Bonneville T100	'01	12	N/A	-	-	-	-	-	-	-	-	X	X	X	X	X	-	X	X	X	
Daytona 600 & 650	'03	'05	160	X	X	-	-	X	-	-	-	X	-	X	-	X	-	X	X	X	
Daytona 675 Triple	'06	12	160	X	X	-	-	X	-	-	-	X	-	X	-	X	-	X	X	X	
Daytona 955i	'99	'06	160	X	X	-	-	X	-	-	-	X	X	X	X	X	-	X	X	X	
Rocket III	'04	12	160	X	X	-	-	-	-	-	-	X	X	X	X	X	-	X	X	X	
Speed Four	'03	'06	160	X	X	-	-	X	-	-	-	X	-	X	X	X	-	X	X	X	
Speed Triple 1050	'05	12	160	X	X	-	-	X	-	-	-	X	X	X	X	X	-	X	X	X	
Speed Triple 955i	'01	'04	160	X	X	-	-	X	-	-	-	X	X	X	X	X	-	X	X	X	
Speedmaster	'02	12	N/A	-	-	-	-	-	-	-	-	X	X	-	-	-	-	X	-	-	
Sprint RS 955	'99	'04	160	X	X	-	-	X	-	-	-	-	X	-	-	-	-	X	-	-	
Sprint ST 1050, 1050 GT	'05	12	160	X	X	-	-	X	-	-	-	X	X	X	X	X	-	X	X	X	
Sprint ST 955	'99	'04	160	X	X	-	-	X	-	-	-	-	X	-	-	-	-	X	-	-	
Street Triple 675	'08	12	160	X	X	-	-	-	-	-	-	-	X	X	-	X	-	X	X	X	
Tiger 800	'11	12	160	-	-	-	-	-	-	X	X	X	-	-	-	X	-	X	X	X	
Tiger 800 XC	'11	12	160	-	-	-	-	-	-	X	X	X	-	-	-	X	-	X	X	X	
Thruxton 900	'04	12	N/A	-	-	-	-	-	-	-	-	X	X	X	X	X	-	X	X	X	
Tiger 900i	'99	'01	160	X	X	X	X	-	-	X	X	X	-	X	-	X	-	X	X	X	
Tiger 955i	'01	'06	160	X	X	X	X	-	-	X	X	X	X	X	-	X	-	X	X	X	
Tiger 1050	'07	12	160	X	X	-	-	X	X	X	X	X	X	-	X	-	X	-	X	X	
Trophy 900	'90	'02	160	X	X	-	-	X	-	-	-	-	-	-	-	-	-	X	-	-	
Trophy 1200	'90	'04	110	X	X	-	-	-	-	-	-	-	-	-	-	-	-	X	-	-	
TT 600	'00	'03	160	X	X	X	-	X	-	-	-	-	-	-	-	-	-	X	-	-	
Scrambler	'06	12	N/A	-	-	-	-	-	-	-	-	-	X	X	-	X	-	X	X	X	
Victory																					
	From	To	Ring	QUICK-LOCK Tankbags				Strap	Rear Bags				Dry Bags								
Hammer & Hammer S w/o optional V-drag bars	'05	'05	110	X	X	-	-	-	-	-	-	-	-	-	X	-	-	-	-	-	
Kingpin Tour	'05	'05	110	X	X	-	-	-	-	-	-	-	-	-	X	-	-	-	-	-	
Kingpin	'05	'05	110	X	X	-	-	-	-	-	-	-	-	-	X	-	-	-	-	-	
Vegas	'05	'05	110	X	X	-	-	-	-	-	-	-	-	-	X	-	-	-	-	-	
Yamaha																					
	From	To	Ring	QUICK-LOCK Tankbags				Strap	Rear Bags				Dry Bags								
FJR1300	'01	'05	110	X	X	X	X	X	-	-	-	-	X	-	X	-	X	-	X	X	X
FJR1300	'06	'12	110	X	X	X	X	X	-	-	-	-	X	-	X	-	X	-	X	X	X
FZ1 / FZS1000 Fazer	'01	'05	110	X	X	X	X	-	-	-	-	-	X	-	X	-	X	-	X	X	X
FZ1 / FZS1000 Fazer	'06	'12	110	X	X	X	X	X	X	-	-	-	X	X	X	X	X	-	X	X	X
FZ6	'04	'12	110	X	X	X	X	-	X	-	-	-	X	-	X	-	X	-	X	X	X
FZ-6R	'10	'12	110	X	X	-	-	-	-	-	-	-	X	-	X	-	X	-	X	-	-
FZ8	'10	'12	110	X	X	-	-	-	-	-	-	-	-	-	-	-	-	X	-	X	-
Super Tenere 1200	'10	'12	110	X	X	X	-	-	-	X	X	X	-	X	-	X	-	X	X	X	X
V-Max	'85	'11	*D	-	-	-	-	-	-	-	-	-	-	-	X	X	-	X	-	-	-
XV1700 Warrior	'05	'05	110	X	X	-	-	-	-	-	-	-	-	-	-	-	-	-	X	-	-
XV250 Virago	'05	'05	N/A	-	-	-	-	-	-	-	-	-	-	-	-	-	-	-	X	-	-
XV535 Virago	'05	'05	N/A	-	-	-	-	-	-	-	-	-	-	-	-	-	-	-	X	-	-
XVS1100 V-Star / V-Star Classic	'05	'05	N/A	-	-	-	-	-	-	-	-	-	X	X	X	X	X	-	X	X	X
XVS650 V-Star / V-Star Classic	'05	'05	N/A	-	-	-	-	-	-	-	-	-	X	X	X	X	X	-	X	X	X
XVZ1600 / XVZ1700 Road Star	'05	'05	N/A	-	-	-	-	-	-	-	-	-	X	X	X	X	X	-	X	X	X
YZF1000	'94	'05	110	X	X	-	-	X	-	-	-	-	X	X	X	X	X	-	X	X	X
YZF600R	'94	'08	110	X	X	-	-	X	-	-	-	-	X	X	X	X	X	-	X	X	X
YZF-R1	'98	'12	110	X	X	-	-	X	-	-	-	-	X	X	X	X	X	-	X	X	X
YZF-R6	'99	'02	110	X	X	-	-	X	-	-	-	-	X	X	X	X	X	-	X	X	X
YZF-R6	'03	'12	110	X	X	-	-	X	-	-	-	-	X	X	X	X	X	-	X	X	X
WR250R & WR250X	'08	'12	N/A	-	-	-	-	-	-	X	X	X	X	X	X	X	-	X	X	X	X

Notes

*D = In development
 TWT Requires TWT.TRT.00.006.100 Drill-on Tankring Kit
 GTR Requires TRT.00.475.140.GTR

Compact Tents & Sleeping Pads



Morpho 1P™ is the solo version of the Nemo Morpho 2P™ tent. Thanks to smaller diameter airbeams, Morpho 1P™ inflates faster and packs considerably smaller than its bigger brother, while retaining the same comfort and spaciousness.

Both tents come with venting compression dry bags and super strong aluminum X-stakes.

Even the tallest guy in the office (6'2") fits comfortably inside both versions of the Morpho tent.

Morpho 1P™

NEMO.892802002739

\$369.95*

*See website for current price.

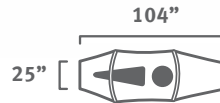

Morpho 1P™ packed
25 x 18 cm dia. (10" x 7" dia.)
1.8 kg (3.9 lbs)

Morpho 2P™

NEMO.892802002746

\$429.95*

*See website for current price.

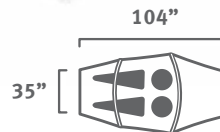

Morpho 2P™ packed
35.5 x 18cm dia. (14" x 7" dia.)
2.4 kg (5.4 lbs)

New Boot Cut™ on Morpho 2P™ gives two pairs of boots a dry home for the night.



Nemo camping gear packs extremely small.

A NEMO Morpho 2P™ tent (with its pump), Cosmo™ (see page 155) sleeping pad and Fillo™ (see page 155) pillow fit in a Coocase V37 Topcase.

Inflates quickly using the integrated foot pump



Morpho tents use Inflatable Airbeams instead of standard tent poles. This means that they're lighter, pack smaller and are super fast to set up and tear down. If you're setting up in the rain, you can stake out your tent, climb inside, and inflate the tent from within. No getting wet!

	Morpho 1P™	Morpho 2P™
Capacity	1	2
Frame	5.1 cm (2") dia. Airbeam	8.9 cm (3.5") dia. Airbeam
Shell Fabric	40D OSMO™ W/B / 30D PU Nylon	40D OSMO™ W/B
Vestibule Fabric	30D PU Nylon	30D PU Nylon
Interior Height	37 in / 94 cm	42 in / 107 cm
Floor Area	30 sq ft / 2.8 sq m	39 sq ft / 3.6 sq m
Vestibule Area	7 sq ft / 0.7 sq m	14 sq ft / 1.3 sq m

Footprint™

Even with the best care, a tent floor is susceptible to damage after countless trips in the wilderness. Our Footprint, made of tough 70 denier Polyurethane coated Nylon ripstop, goes under your tent to protect the floor from sharp items on the ground.

1-Person: NEMO.814041010092:
MSRP: **\$44.95***

2-Person: NEMO.814041010115:
MSRP: **\$44.95***



Pawprint™

The Pawprint™ is a removable liner for the inside of your tent. It has the double function of protecting your tent floor from boots and paws while adding comfort. Pawprint™ is made of a machine washable, brushed fabric that is very soft to the touch. Place your sleeping pads underneath to help them stay in place.

1-Person: NEMO.814041010108:
MSRP: **\$49.95***

2-Person: NEMO.814041010122:
MSRP: **\$49.95***



**See website for current price.*

Cosmo™ Air Sleeping Pad

Cosmo Air™ is a lightweight sleeping pad with a built-in pump. This pad has a generous 3" thickness but weighs only about 2 lbs, making it ideal for backpacking, motorcycling, or other ultralight travel. Packs down smaller than typical self-inflating mattresses that are only 1/2" thick! The Cosmo™ takes only 1.5 minutes to inflate!

Included: Stuff sack, compression strap, and repair patches.

NEMO.814041010276:

MSRP: **\$129.95***

**See website for current price.*

Packed size:

9" x 4.5" diameter
1 lb 13 oz



Inflates quickly using the integrated foot pump.



Astro™ Insulated Sleeping Pad

Astro™ is an insulated sleeping pad that uses a thin layer of polyurethane foam welded to the inner surface of the pad to stop convective currents, creating a very consistent, even insulation. It uses an integrated valve for inflation. When inflated the Astro™ gives you 2.5" of pad thickness.

Included: Stuff sack, compression strap, and repair patches.

NEMO.814041011211:

MSRP: **\$99.95***

**See website for current price.*

Packed size:

8.5" x 4.5" diameter
1 lb 8oz



Which one is for you?

The Cosmo inflates in under 2 minutes using the integrated foot pump. It is larger and comfier when inflated and has a larger packed size than the Astro.

The Astro takes about 10 minutes to inflate by breathing and can also be inflated with an electric air compressor. The Astro is smaller, less expensive, and provides insulation for use in sub-freezing weather.



Fillo™ Travel Pillow

Fillo™ is our favorite travel pillow. The Fillo™ features 3" thick inflatable cells, 1" of memory foam, and a microfiber top. The Fillo™ cover is made of a velvety-soft machine-washable microfiber fabric. NEMO.814041010436: MSRP: \$39.95



An integrated shock cord allows you to add clothing and increase the height of Fillo™ for optimal neck support.

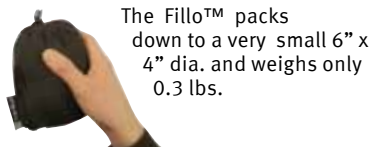

The Fillo™ packs down to a very small 6" x 4" dia. and weighs only 0.3 lbs.

Oxford First Aid Kit

Compact size (4" x 5.7" x 1.8"). Contains hygienically-sealed medical supplies.

Kit contains:

- 1x adhesive plaster tape
- 8x adhesive plaster bandages
- 2x sterile bandages
- 1x sterile compress (burn dressing)
- 1x scissors
- 4x disposable gloves
- 1x first aid manual
- 1x first aid blanket (160cm x 210cm)



OXF.OF238: **\$19.99**

ALU-RACK, black



Crashbars



Centerstand



See more at TwistedThrottle.com/MyBike

G450X	from	to	Notes	Part Number
Barkbusters Handguards	'08	'11	For extra clearance around the brake hose use BB.B54. See page 12.	BB.BHG1
R&G Front Axle Sliders	'08	'11	See page 19.	RG.FP0088BK
G650 XCountry	from	to	Notes	Part Number
ALU-RACK, black	'07	'09	Topcase Adapter not included. See page 82.	GPT.07.613.100
Crashbars, black	'07	'09	Compatible with original BMW skid plate. See page 4.	SBL.07.629.100
R&G Frame Sliders	'07	'09	Also fits G650 X Challenge and the G650 X Moto	RG.CP0209BL
R&G Rear Axle Sliders	'07	'09	Also fits G650 X Challenge & G650 X Moto	RG.SS0021BK
G650 XChallenge	from	to	Notes	Part Number
ALU-RACK, black	'07	'08	Topcase Adapter not included. See page 82.	GPT.07.613.100
Crashbars, black	'07	'09	Compatible with original BMW skid plate. See page 4.	SBL.07.629.100
Centerstand	'07	'09	Includes lifting handle. See page 6.	HPS.07.628.100
G650 XMoto	from	to	Notes	Part Number
ALU-RACK, black	'07	'08	Topcase Adapter not included. See page 82.	GPT.07.613.100
Crashbars, black	'07	'09	Compatible with original BMW skid plate. See page 4.	SBL.07.629.100
R&G Front Axle Sliders	'07	'08	For the G450X and G650 XMoto. See page 19.	RG.LP0049BK



F650GS single



View our **F650GS** project bike video.

See more at TwistedThrottle.com/MyBike

Crashbars



QUICK-LOCK EVO Sidecarrier



Centerstand



F650GS single / G650GS	from	to	Notes	Part Number
Steel Toprack, black	'04	'10	Provides easy access to rear storage compartment. For use with all QUICK-LOCK adapter plates. See page 80.	GPT.07.353.20001.B
Centerstand	'00	'10	Fits F650GS/Dakar only. See page 6.	Various
QUICK-LOCK EVO Sidecarrier	'00	'10	For TraX ALU-BOX: Sidecase Adapter not included.	KFT.07.094.200
QUICK-LOCK EVO Tankring	'08	'10	For mounting QUICK-LOCK tankbags	TRT.00.640.20100.S
QUICK-LOCK GPS Holder	'08	'10	Vibration damped. Black. See page 55.	GPS.07.646.10300.B
Skid Plate	'00	'10	Aluminum. See page 7.	MSS.07.812.10000
Crashbars	'00	'10	Black steel. See page 4.	SBL.07.101.100
Master Cylinder Guard: rear	'00	'10	Fits F650GS '00 - '07 and G650GS '09 - '10	BPS.07.175.10100.S
Mirror Widener	'00	'10	Universal mirror widener See page 30.	SVL.00.505.101
Givi windscreen, clear	'04	'10	15.5" h x 17.3" w, Clear. Use on F650GS / Dakar requires removal of original handguards	Givi D331ST



2011 G650GS



2012 G650GS Sertao

[See more at TwistedThrottle.com/MyBike](http://TwistedThrottle.com/MyBike)

Master Cylinder Guard: rear



Steel Toprack



MRA X-screen



QUICK-LOCK EVO Sidecarrier



Barkbusters Handguards



G650GS/ G650GS Sertao	from	to	Notes	Part Number
Steel Toprack	'11	'12	Provides easy access to rear storage compartment For use with all QUICK-LOCK adapter plates	GPT.07.353.20001.B
ALU-RACK, silver	'11	'12	Allows access to the trunk. See page 82.	GPT.07.353.100.S
QUICK-LOCK EVO Sidecarrier	'11	'12	Sidecase Adapter not included. See page 84.	KFT.07.094.20000
QUICK-LOCK EVO Tankring	'11	'12	For mounting QUICK-LOCK tankbags. See page 120.	TRT.00.640.20500.B
QUICK-LOCK GPS Holder	'11	'12	Vibration damped. Black. See page 55.	GPS.07.646.10000.B
Skid Plate	'11	'12	See page 7.	MSS.07.812.10000.B
Crashbars, black	'11	'12	Mild steel. See page 4.	SBL.07.775.10000.B
Master Cylinder Guard: rear	'11	'12	Aluminum, silver See page 8.	BPS.07.175.10100.S
Mirror Widener	'11	'12	Universal mirror widener. See page 30.	SVL.00.505.102
Barkbusters Handguards	'11	'12	See page 12.	BB.BHG45
MRA Windscreens	'11	'12	Several shapes available: See page 36.	Various

Crashbars



Skid Plate



QUICK-LOCK EVO Tankring



F650GS twin



QUICK-LOCK EVO Tankring



Handlebar Risers



See more at TwistedThrottle.com/MyBike

On/Off-road Footpegs



QUICK-LOCK EVO Sidecarriers



Centerstand



Regulator Guard



Chain Guard



Crashbars



F650GS (2008 & Later)	from	to	Notes	Part Number
Steel Toprack	'08	'12	Accepts TraX, Coocase, & Givi topcases. See page 80.	GPT.07.558.20001.B
QUICK-LOCK EVO Sidecarrier	'08	'12	For TraX ALU-BOX: Sidecase Adapter not included	KFT.07.559.200
QUICK-LOCK EVO Tankring	'08	'12	Spider tankring. No drilling required. See page 120.	TRT.00.640.20100.B
QUICK-LOCK GPS Holder	'08	'12	Vibration damped. Black. See page 55.	GPS.07.646.10300.B
Skid Plate	'08	'12	Aluminum. See page 7.	MSS.07.473.100
Crashbars, black	'08	'12	See page 4.	SBL.07.556.100
Chain Guard	'08	'12	Aluminum, silver	KTS.07.125.100
Master Cylinder Guard: rear	'08	'12	Aluminum, silver. See page 8.	BPS.07.175.10100.S
Regulator Guard	'08	'12	Aluminum, silver. See page 8.	SCT.07.174.10100.S
Headlight Guard	'08	'12		LPS.07.387.100
Mirror Widener	'08	'12	Universal mirror extension. See page 30.	SVL.00.505.102
Handlebar Risers	'08	'12	See page 10: 20 mm (0.8") & 30mm (1.2") rise	LEH.07.039.118
Auxiliary Light Mount	'08	'12	See page 64 for Denali LED lighting.	TM.51005
On/Off-road Footpegs	'08	'12	Stainless steel. Silver. See page 34.	FRS.07.011.10000.S
Centerstand	'08	'12	See page 6.	HPS.07.470.100
Sidestand Foot	'08	'12	Silver foot, black mount. See page 8.	STS.07.102.10100.S
R&G Bar End Sliders	'08	'12	See page 19.	RG.BE0047BK
Barkbusters Handguards	'08	'12	See page 12.	BB.BHG32
MRA windscreen	'08	'12	VarioTouringScreen: See page 37.	MRA.07.017.VTM



View our F800GS project bike video.



F800GS

See more at TwistedThrottle.com/MyBike

Headlight Guard



Vibration-Damped GPS Holder



QUICK-LOCK EVO Sidecarrier



Crashbars



Skid Plate



Centerstand



F800GS (2008 & Later)	from	to	Notes	Part Number
Steel Toprack	'08	'12	Accepts several different topcases. See page 80.	GPT.07.558.20001.B
QUICK-LOCK EVO Tankring	'08	'12	Spider tankring. No drilling required. See page 120.	TRT.00.640.20100.B
QUICK-LOCK EVO Sidecarrier	'08	'12	For TraX ALU-BOX: Sidecase Adapter not included	KFT.07.559.200
Vibration-Damped GPS Holder	'08	'12	Detachable, vibration damped. See page 55.	GPS.07.561.10000
Skid Plate	'08	'12	Aluminum. See page 7.	MSS.07.560.100
Master Cylinder Guard: rear	'08	'12	Aluminum, silver. See page 8.	BPS.07.175.10100.S
Regulator Guard	'08	'12	Aluminum, silver. See page 8.	SCT.07.174.10100.S
Crashbars, black	'08	'12	See page 4.	SBL.07.556.100
Chain Guard	'08	'12	Aluminum, silver.	KTS.07.125.100
Headlight Guard	'08	'12		LPS.07.387.100
Mirror Widener	'08	'12	Universal mirror extension. See page 30.	SVL.00.505.102
Handlebar Risers	'08	'12	See page 10: 20 mm (0.8") & 30mm (1.2") rise	LEH.07.039.118
Centerstand	'08	'12	See page 6.	HPS.07.557.100
Sidestand Foot	'08	'12	See page 8.	STS.07.102.10100.S
On/Off-road Footpegs	'08	'12	Stainless steel. Silver. See page 34.	FRS.07.011.10100.S
R&G Front Axle Sliders	'08	'12	See page 19.	RG.FP0089BK
Fenda Extenda	'08	'12		PP.054201
MRA Windscreen	'08	'12	Shape: VarioTouringScreen. See page 37.	MRA.07.017.VTM
Barkbusters Handguards	'08	'12	See page 12.	BB.BHG32

Steel Toprack



On/Off-road Footpegs



Rear Master Cylinder Guard



Regulator Guard



R&G Bar End Slider



SW-MOTECH Frame Slider



ALU-RACK, black



QUICK-LOCK EVO Tankring



Blaze Sport Saddlebags



QUICK-LOCK EVO Sidecarrier



F800R

See more at TwistedThrottle.com/MyBike

F800R	from	to	Notes	Part Number
ALU-RACK, black	'09	'12	Topcase Adapter not included. See page 82.	GPT.07.306.100.B
Centerstand	'09	'12	Professional installation recommended. See page 6.	HPS.07.669.10000.B
QUICK-LOCK EVO Sidecarrier	'09	'12	Sidecase Adapter not included. See page 84.	KFT.07.665.20000.B
QUICK-LOCK EVO Tankring	'09	'12	Spider tankring. No drilling required. See page 120.	TRT.00.640.20600.B
QUICK-LOCK GPS Holder	'09	'12	Shock-absorbent. Black. See page 55.	GPS.07.646.10100.B
Blaze Sport Saddlebags	'09	'12	QUICK-LOCK, Nylon, Black. See page 88.	HTA.07.740.10200
Crashbars, black	'09	'12	See page 4.	SBL.07.304.100.B
Chain Guard	'09	'12	Aluminium. Silver.	KTS.07.698.10000.S
Brake Fluid Reservoir Kit	'09	'12	Anti-vibration relocation kit. Front.	CPA.07.596.100
Mirror Widener	'09	'12	Universal, black. 32mm height. See page 30.	SVL.00.505.101
Mirror Widener	'09	'12	Universal, black. 47mm height. See page 30.	SVL.00.505.102
Handlebar Risers & Barbacks	'09	'12	See page 10 (LEH.00.039150 or LEH.00.039.152)	Various
On/Off-road Footpegs	'09	'12	Stainless steel. Silver. See page 34.	FRS.05.011.10000.S
SW-MOTECH Frame Slider Kit	'09	'12	Frame Slider / model-specific mounting. In pairs.	STP.07.590.10500.B
Barkbusters Handguards	'09	'12	See page 12.	S7
R&G Bar End Sliders	'09	'12	See page 19.	RG.BE0049BK

Crashbars, black



Centerstand





F800S

[See more at TwistedThrottle.com/MyBike](http://www.TwistedThrottle.com/MyBike)

ALU-RACK, black



QUICK-LOCK EVO Sidecarrier



Crashbars, black



F800S	from	to	Notes	Part Number
ALU-RACK, black	'06	'10	Topcase Adapter not included. See page 82.	GPT.07.306.100.B
QUICK-LOCK EVO Sidecarrier	'06	'10	Sidecase Adapter not included. See page 84.	KFT.07.305.20000.B
QUICK-LOCK EVO Tankring	'06	'10	Spider tankring. No drilling required. See page 120.	TRT.00.640.20600.B
Crashbars, black	'06	'10	See page 4.	SBL.07.304.100.B
Centerstand	'06	'10	See page 6.	HPS.07.303.100
Fenda Extenda	'06	'10	No cutting required.	PP.054200
CAN-BUS Electrical Connector	'06	'10	Provides a trigger wire to activate a relay to power other accessories.	EC.02350
MRA Windscreen	'06	'10	TouringScreen and VarioTouringScreen shapes available: See page 36.	MRA.07.016

[See more at TwistedThrottle.com/MyBike](http://www.TwistedThrottle.com/MyBike)

F800ST



Centerstand



SW-MOTECH Frame Slider



MRA VarioTouringScreen



F800ST	from	to	Notes	Part Number
ALU-RACK, black	'06	'12	Topcase Adapter not included. See page 82.	GPT.07.306.100.B
Centerstand	'06	'12	See page 6.	HPS.07.303.100
QUICK-LOCK EVO Sidecarrier	'06	'12	Sidecase Adapter not included. See page 84.	KFT.07.305.20000.B
QUICK-LOCK EVO Tankring	'06	'12	Spider tankring. No drilling required. See page 120.	TRT.00.640.20600.B
Handlebar Risers & Barbacks	'06	'12	See page 10 (LEH.00.039.150 or LEH.00.039.152).	Various
Mirror Wideners	'06	'12	Profile. See page 30.	SVL.07.501.10800.B
SW-MOTECH Frame Sliders	'06	'12	See page 28.	STP.07.590.10400.B
R&G Front Axle Sliders	'06	'12	See page 19.	RG.FP0057BK
R&G Bar End Sliders	'06	'12	See page 19.	RG.BE0033BK
MRA Windscreen	'06	'12	TouringScreen and VarioTouringScreen shapes available: See page 36.	MRA.07.016

S1000RR



RAM Ball Stem Mount



SW-MOTECH QUICKLOCK EVO Tankring



SW-MOTECH Mirror Widener



SW-MOTECH BAGS-CONNECTION

[See more at TwistedThrottle.com/MyBike](http://TwistedThrottle.com/MyBike)

SW-MOTECH Items	Year	Notes	Part Number
QUICK-LOCK EVO Tankring	'10 '12	Fiber reinforced Nylon. Black. No screws. See page 120.	TRT.00.640.12700.B
QUICK-LOCK Electric Tankring	'10 '12	12 V. Fiber reinforced Nylon. Grey. No screws.	TRE.00.475.12700
Auxiliary Light Mount	'10 '12	See page 64 for Denali LED lighting.	TT-D1.020.M5
Mirror Wideners	'10 '12	Profile. Black. See page 30.	SVL.07.501.10900.B
Frame Slider	'10 '12	Frame Slider / model-specific mounting. In pairs.	STP.07.590.10600.B
Bags-Connection Tank & Rearbags	'10 '12	Several sizes & profiles. See page 127-143.	Various
Blaze Sport Saddlebags	'10 '12	QUICK-LOCK, Nylon, Black. 14-21 liters per bag. See page 88.	HTA.07.740.10000
RAM Ball Stem Mount	'10 '12	Places a RAM ball into the steering stem for mounting GPS and other devices. Arms and cradles sold separately. See page 56.	CPA.00.424.13100.B

SW-MOTECH Frame Slider Kit



Blaze Sport Saddlebags





View our S1000RR project bike video.

The Twisted BMW S1000RR



See more at TwistedThrottle.com/MyBike

R&G Items see pages 18-27	from	to	Notes	Part Number
R&G Frame Sliders	'10	'12	No cutting required. See page 18.	RG.CP0263.BL
R&G Fender Eliminator	'10	'12	Includes an LED license plate illumination light.	RG.LP0092BK
R&G Front Axle Sliders	'10	'12	For the front forks. See page 19.	RG.FP0093BK
R&G Bar End Sliders	'10	'12	See page 19.	RG.BE0050BK
R&G Adjustable Rearsets	'10	'12	Street version. See page 21.	RG.RSET01BK
R&G Adjustable Rearsets	'10	'12	Race version.	RG.RSET04BK
R&G Offset Swingarm Spools	'10	'12	See page 19.	RG.CR0033BK
R&G Swingarm Spools	'10	'12	See page 19.	RG.CR0032BK
R&G Mirror Block-Off Plates	'10	'12	See page 22.	RG.MBP0002BK
R&G Passenger Peg Blanking Plates	'10	'12	See page 22.	RG.BLP0002BK
R&G Frame Plug	'10	'12	Right hand side. See page 22.	RG.FI0028BK
R&G Frame Plug	'10	'12	Left hand side. See page 22.	RG.FI0027BK
R&G Engine Case Cover	'10	'12	Generator Cover (left hand side). See page 20.	RG.ECC0043BK
R&G Engine Case Cover	'10	'12	Water Pump Cover (right hand side). See page 20.	RG.ECC0044BK
R&G Engine Case Cover	'10	'12	Clutch Cover (right hand side). See page 20.	RG.ECC0045BK
R&G ABS Toe Chain Guard	'10	'12	Black. See page 22.	RG.TG0006BK
R&G Oil Cooler Guard	'10	'12	See page 20.	RG.OCG0005BK
R&G Radiator Guard	'10	'12	See page 20.	RG.RAD0087BK

R&G Fender Eliminator



R&G Frame Plug & Adjustable Rearset



R&G Bar End Slider

R&G Engine Case Covers

R&G Aero Frame Slider



R&G Mirror Block-off Plate



R&G Front Axle Slider



R&G Offset Swingarm Spool





R1150GS Adventure



R1150GS

See more at TwistedThrottle.com/MyBike

Barkbusters Handguard



On/Off-road Footpegs



MRA Windscreen



R1100GS, R1150GS & Adventure	from	to	Notes	Part Number
ALU-RACK, silver	'93	'04	For R1150GS only: Topcase Adapter not included. See page 82.	GPT.07.337.100.S
Steel Toprack	'02	'05	For R1150GS Adventure only : Accepts TraX, Coccase, & Givi topcases. See page 80.	GPT.07.726.20001.B
Steel Toprack	'93	'04	For 1150 GS only : Accepts TraX, Coccase, & Givi topcases. See page 80.	GPT.07.337.20001.B
QUICK-LOCK EVO Sidecarrier	'93	'05	See page 84.	KFT.07.093.200
QUICK-LOCK EVO Tankring	'93	'05	See page 120.	TRT.00.640.12000.B
Crashbars: R1150GS	'95	'04	For R1150GS only. Silver. See page 4.	SBL.07.409.100
Crashbars: R1150GS Adventure	'02	'05	For R1150GS Adventure only. Silver. See page 4.	SBL.07.408.100
Barkbusters Handguards	'93	'05	See page 12.	BB.BHG20
Mirror Widener	'93	'05	Universal mirror widener. See page 30.	SVL.00.505.101
Handlebar Risers & Barbacks	'93	'05	See page 10 (LEH.00.039.150 or LEH.00.039.152). See page 10.	Various
Auxiliary Light Mount	'95	'05	For Denali LED lighting. See page 64.	NSW.07.004.10100
On/Off-road Footpegs			Stainless steel. Silver. See page 34.	FRS.07.011.10500.S
MRA Windscreen	'93	'05	VarioScreen: See page 36.	Various

QUICK-LOCK EVO Sidecarrier



Crashbars: R1150GS



Crashbars: R1100GS





R1100GS

[See more at TwistedThrottle.com/MyBike](http://TwistedThrottle.com/MyBike)

Crashbar



ALU_RACK, silver



Quick-Lock EVO Sidecarrier



R1100GS	from	to	Notes	Part Number
ALU-RACK, silver	'94	'99	Topcase Adapter not included. See page 82.	GPT.07.337.100.S
Quick-Lock EVO Sidecarrier	'94	'99	Sidecase Adapter not included. See page 84.	KFT.07.093.200
QUICK-LOCK EVO Tankring	'94	'99	See page 120.	TRT.00.640.12000.B
QUICK-LOCK GPS Holder	'94	'99	Detachable Vibration-Damped GPS Holder for 10mm - 12.5mm diameter handlebar crossbars.	GPS.00.646.10500.B
Crashbars	'94	'99	Rally style, silver. See page 4.	SBL.07.405.100
Handlebar Riser & Barbacks	'94	'99	(LEH.00.039.160, LEH.00.039150 or LEH.00.039.152) See page 10.	Various
Barkbusters Handguards	'94	'99	(BB.S4 or BB.BHG20) See page 12.	Various



R1150R Roadster



R1150 Rockster

[See more at TwistedThrottle.com/MyBike](http://TwistedThrottle.com/MyBike)

ALU-RACK, black



QUICK-LOCK Sidecarrier



Crashbars, silver



R1150R and R1150R Rockster	from	to	Notes	Part Number
ALU-RACK, black	'00	'06	Topcase Adapter not included. See page 82	GPT.07.345.100.B
QUICK-LOCK Sidecarrier	'00	'06	Sidecase Adapter not included. See page 84.	KFT.07.169.100
QUICK-LOCK EVO Tankring	'00	'06	See page 120.	TRT.00.640.12000.B
Crashbars, silver	'00	'06	See page 4.	SBL.07.344.100
Handlebar Risers & Barbacks	'00	'06	See page 10 (LEH.00.039.150 or LEH.00.039.152)	Various
Mirror Widener	'00	'06	Universal mirror widener. See page 30.	SVL.00.505.101
MRA Windscreen	'00	'06	Several shapes available: See page 36.	Various
Barkbusters Handguards	'00	'06	Mounts to the outside of the bars. See page 12.	BB.S7

Steel Toprack



Headlight Guard, ('08-'12)



Skid Plate



Upper Crashbar ('04-'07)



Lower Crashbar ('04-'12)



Cylinder Head Guard



Master Cylinder Guard: rear



View our R1200GS Project bike video.



R1200GS (2008 & Later)

[See more at TwistedThrottle.com/MyBike](http://TwistedThrottle.com/MyBike)

R1200GS	from	to	Notes	Part Number
Steel Toprack	'04	'12	Accepts TraX, Coocase, & Givi topcases. See page 80.	GPT.07.352.20001.B
QUICK-LOCK EVO Sidecarrier	'04	'12	Sidecase Adapter not included. See page 84.	KFT.07.311.200
QUICK-LOCK EVO Sidecarrier	'04	'12	Exhaust relocation adapter included	KFT.07.311.25000.B
QUICK-LOCK GPS Holder	'04	'07	Vibration damped. Black. See page 55.	GPS.07.646.10500.B
QUICK-LOCK GPS Holder	'08	'09	Vibration damped. Black.	GPS.07.646.10700.B
SW-MOTECH Luggage Toprack	'04	'12	Aluminium. Silver.	GPB.07.710.10000.S
QUICK-LOCK EVO Tankring	'04	'07	See page 120.	TRT.00.640.12000.B
QUICK-LOCK EVO Tankring	'08	'08	For screwless gascap. See page 120.	TRT.00.640.12300.B
QUICK-LOCK EVO Tankring	'09	'12	For screwless gascap. See page 120.	TRT.00.640.12700
QUICK-LOCK Electric Tankring	'09	'12	12 V. Fiber reinforced Nylon. Grey. No screws.	TRE.00.475.12700
Upper Crashbar, silver	'04	'07	This upper crashbar must be used in combination with SBL.07.562.100. Includes integrated light mount.	SBL.07.552.100
Lower Crashbar, silver	'04	'12	See page 4.	SBL.07.562.100
Upper Crashbar, silver	'08	'12	This upper crashbar can only be mounted in combination with SBL.07.562.100. Includes integrated light mount.	SBL.07.565.100
Cylinder Head Guard	'08	'09	Aluminum. Sold in pairs	MSS.07.709.10000.S
Cylinder Head Guard	'10	'12	Aluminum Silver & anodized black. Replacement "puck" available.	MSS.07.706.10000.S
Replacement "Puck" for Cylinder Head Guard	'10	'12	Left & right available separately. CNC machined black anodized aluminum.	MSS.07.754.900
Skid Plate	'06	'12	Aluminum. See page 7.	MSS.07.706.10000.S
Centerstand Guard, Aluminum	'06	'12	See page 6.	MSS.07.707.10000.S
Master Cylinder Guard: rear	'08	'12	Silver. See page 8.	BPS.07.175.10000.S
On/Off-road Footpegs	'04	'12	Stainless steel. Silver. See page 34.	FRS.07.011.10500.S
SW-MOTECH Swingarm Sliders	'04	'12	Black.	STP.07.176.10000.B
SW-MOTECH Front Axle Sliders	'04	'12	Black. In pairs.	STP.07.176.10100.B
Cigarette Lighter Socket Bracket	'08	'09	Mounts cigarette outlet to handlebar clamp.	CPA.07.006.18000.B
Mirror Widener	'04	'07	Universal mirror widener. See page 30.	SVL.00.505.102
Handlebar Risers, black	'06	'07	30mm (1.2") rise height. See page 10.	LEH.07.039.111.B
Handlebar Risers, silver	'08	'12	30mm (1.2") rise height. See page 10.	LEH.07.039.117.S
Barkbusters Handguards	'04	'12	See page 12.	BB.BHG32



R1200GS
(2007 & Earlier)

[See more at TwistedThrottle.com/MyBike](http://TwistedThrottle.com/MyBike)

R1200GS	from	to	Notes	Part Number
Handlebar Riser & Barbacks, silver	'08	'12	Moves the handlebars up 20 mm & back 30 mm. See page 10.	LEH.07.039.12200.S
Headlight Guard	'04	'07	Flexible PVC shield with silver frame.	LPS.07.388.100
Headlight Guard	'08	'12	Hard PVC panel with black frame.	LPS.07.358.10000.B
Oil Cooler Guard	'09	'12	Aluminum, black. See page 9.	KLS.07.719.10000.B
Radiator Guard	'08	'12	Aluminum, silver. See page 9.	SCT.07.174.10200.S
Sidestand Foot	'04	'12	Silver. Foot / mounting. See page 8.	STS.07.102.10000.S
Auxiliary Headlight Mounting bar	'04	'12	See page 64 for Denali LED lighting.	TM.51003
Auxiliary Light Mount	'08	'12	See page 64 for Denali LED lighting.	NSW.07.563.10001
Frame Cap Set	'04	'12	Black. In pairs.	RAD.07.737.10000.B
R&G Swingarm Sliders	'04	'12	Protects the right side of the swingarm. See page 19.	RG.SP0012BK
CAN-BUS Electrical Connector	'04	'12	Provides a "hot" trigger wire to activate a relay to power other accessories. See page 70.	EC.02350
Fenda Extenda	'04	'12	Provides extra protection for your radiator and engine.	PP.054160
Kaoko Throttle Lock	'04	'12	Options for: No handguards, OEM handguards, Barkbusters handguards or Touratech handguards. See page 16.	Various
MRA Windscreen	'04	'12	VarioScreen, Vario TouringScreen and X-Creen shapes available. See page 36.	MRA.07.011

Auxiliary Light Mount



QUICK-LOCK GPS Holder



Barkbusters Handguard



Mirror Widener



QUICK-LOCK Electric Tankring



Oil Cooler Guard



Frame Cap Set



QUICK-LOCK EVO Sidecarrier w/ exhaust relocation adapter.

KFT.07.311.25000.B



On/Off-road Footpegs



R&G Swingarm Slider

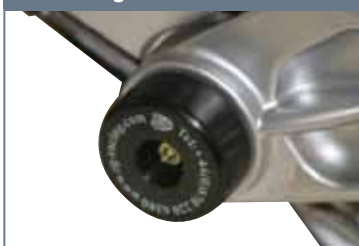

QUICK-LOCK EVO Sidecarrier



MRA X-creen



Handlebar Risers (mounted)



Barkbusters Storm Handguards



QUICK-LOCK GPS Holder



R1200GS Adventure (2008 & Later)

See more at TwistedThrottle.com/MyBike

R1200GS Adventure	from	to	Notes	Part Number
Steel Toprack	'08	'12	Accepts TraX, Coocase, & Givi topcases.	GPT.07.685.20001.B
QUICK-LOCK EVO Sidecarrier	'06	'12	Sidecase Adapter not included. See page 84.	KFT.07.311.200
TraX EVO Sidecase Adapter Kit	'06	'12	Attaches TraX EV O 37 & 45 liter sidecases to the OEM Sidecarrier. Silver.	KFT.00.152.10801.S
QUICK-LOCK EVO Tankring	'06	'07	See page 120.	TRT.00.640.12300.B
QUICK-LOCK GPS Holder	'08	'12	Vibration damped. Black. See page 55.	GPS.07.646.10700.B
Cylinder Head Guard	'04	'09	Aluminum Silver & anodized black. Replacement "puck" available.	MSS.07.706.10000.S
Replacement "Puck" for Cylinder Head Guard	'04	'09	Left & right available separately. CNC machined black anodized aluminum.	MSS.07.754.900
Centerstand Guard, Aluminum	'06	'12	See page 6.	MSS.07.707.10000.S
Oil Cooler Guard	'08	'12	Aluminum, black. See page 9.	KLS.07.719.10000.B
Master Cylinder Guard: rear	'10	'12	Silver. See page 8.	BPS.07.175.10000.S
Mirror Widener	'06	'12	Universal mirror widener. See page 30.	SVL.00.505.102
Handlebar Risers, black	'06	'07	30mm (1.2") rise height. See page 10.	LEH.07.039.111.B
Handlebar Risers & Barbacks	'06	'12	Moves bars up & back diagonally approximately 2".	ROX.3R-P2PP
Sidestand Foot	'08	'12	Silver. Foot / mounting. See page 8.	STS.07.102.10000.S
Cigarette Lighter Outlet Bracket	'08	'09	Mounts cigarette outlet to handlebar clamp.	CPA.07.006.18000.B
Frame Cap Set	'10	'12	Black. In pairs.	RAD.07.737.10000.B
CAN-BUS Electrical Connector	'08	'10	Provides a trigger wire to activate a relay to power other accessories. See page 70.	EC.02350
MRA Windscreen	'08	'12	Several shapes available: See page 36.	MRA.07.011
Kaoko Throttle Lock	'06	'12	Fits with/without BMW handguards OR with Touratech handguards. See page 16.	KAO.CCF400-08
Kaoko Throttle Lock	'06	'12	Fits with Barkbusters handguards. See page 16.	KAO.KBB700-S
Barkbusters Handguards			VPS & Storm handguards (BB.BHG12 or BB.BHG22). See page 12.	Various

Steel Toprack



Kaoko Throttle Lock (KAO.KBB700-S)





R1200RT

See more at TwistedThrottle.com/MyBike

R1200RT	from	to	Notes	Part Number
Topcase Adapter	'05	'12	Used to level out the tail of the R1200RT to place cases such as Coocase & TraX ALU-BOX cases.	R-BMW001-01
QUICK-LOCK EVO Tankring	'05	'12	Compatible with original BMW tank rails: See page 120.	TRT.00.640.12900.B
QUICK-LOCK GPS Holder	'04	'07	Vibration damped. Black. See page 55.	GPS.07.646.10600.B
Handlebar Risers	'05	'12	Moves bars 1" up and 1" back: See page 10.	LEH.07.039.12300.S
Auxiliary Light Mount	'05	'12	See page 64 for Denali LED lighting.	LAH.07.817.10000.B
Cylinder Head Guard	'04	'09	Aluminum Silver & anodized black. Replacement "puck" available.	MSS.07.706.10000.S
Replacement "Puck" for Cylinder Head Guard	'04	'09	Left & right available separately. CNC machined black anodized aluminum.	MSS.07.754.900
MRA X-sreen Clamp-on Windshield Extension	'05	'12	Add a variable height/ angle spoiler to the existing windscreen. See page 37.	MRA.XC
CAN-BUS Electrical Connector	'05	'12	Provides a "hot" trigger wire to activate a relay to power other accessories. See page 70.	EC.02350
Mirror Thread Ball	'05	'12	M10. M10 x 1.25mm thread. ø 1 inch.	RAM-B-349U
MFV Vario Footpeg Mount	'05	'12	Passenger & rider options available See page 32.	Various
Givi Topcase Carrier	'05	'12	For Givi Monokey topcases only.	Givi E193

MRA X-sreen Clamp-on Windshield Extension



Topcase Adapter (w/ Coocase adapter plate)



Cylinder Head Guard



R1200GS pictured

Auxiliary Light Mount - Denali LED light not included



Mirror Wideners



QUICK-LOCK Sidecarrier



Cylinder Head Guard



Crashbars, black



R1200R

See more at TwistedThrottle.com/MyBike

R1200R	from	to	Notes	Part Number
ALU-RACK, black	'07	'10	Not compatible with OEM sidecase carrier. Topcase Adapter not included. See page 82.	GPT.07.612.100
ALU-RACK, black	'11	'12	Not compatible with OEM sidecase carrier. Topcase Adapter not included. See page 82.	GPT.07.186.10000.B
Topcase Adapter	'07	'12	Used to level out the tail of the R1200R to place cases such as Coocase & TraX ALU-BOX cases.	R-BMW001-01
Blaze Sport Saddlebags	'11	'12	QUICK-LOCK, Nylon, Black. See page 88.	HTA.07.740.10100.B
QUICK-LOCK EVO Tankring	'07	'08	For screwless gas cap: See page 120.	TRT.00.640.12300.B
QUICK-LOCK EVO Tankring	'09	'12	For screwless gas cap: See page 120.	TRT.00.640.12700.B
QUICK-LOCK EVO Sidecarrier	'07	'12	Not compatible with OEM sidecase carrier. Sidecase Adapter not included	KFT.07.600.20000.B
QUICK-LOCK GPS Holder	'11	'12	Vibration damped. Black. See page 55.	GPS.07.646.10800.B
Crashbars, black	'07	'10	See page 4.	SBL.07.606.100.B
Cylinder Head Guard	'04	'09	Aluminum Silver & anodized black. Replacement "puck" available.	MSS.07.706.10000.S
Replacement "Puck" for Cylinder Head Guard	'04	'09	Left & right available separately. CNC machined black anodized aluminum.	MSS.07.754.900
Handlebar Risers & Barbacks	'07	'12	See page 10. (LEH.00.039.150 or LEH.00.039.152)	Various
Mirror Widener	'07	'12	Universal mirror widener. See page 30.	SVL.00.505.102
CAN-BUS Electrical Connector	'07	'12	Provides a "hot" trigger wire to activate a relay to power other accessories. See page 70.	CPA.00.424.115
MRA Windscreen	'07	'12	Several shapes available: See page 36.	Various

Aero ABS Sidecases attached to SW-MOTECH QUICK-LOCK EVO Sidecarriers



ALU-RACK, black



R&G Engine Case Slider



GIVI Topcase Carrier



R&G Front Axle Sliders



K1200RS



[See more at TwistedThrottle.com/MyBike](http://TwistedThrottle.com/MyBike)

K1200GT (2003 - 2008)	from	to	Notes	Part Number
QUICK-LOCK GPS Holder	'03	'08	Vibration damped. Black. See page 55.	GPS.07.646.10200.B
QUICK-LOCK EVO Tankring	'03	'08	See page 120.	TRT.00.640.12600.B
GIVI Topcase Carrier	'03	'05	For Givi Monokey or Monolock topcases.	Givi F680
R&G Engine Case Slider	'03	'08	See page 20.	RG.ECS0007BK
MRA X-creeen Adjustable Spoiler	'03	'05	Attaches to original windscreen. See page 37.	MRA.XC
K1200RS	from	to	Notes	Part Number
QUICK-LOCK EVO Tankring	'00	'05	See page 120.	TRT.00.640.12000.B
GIVI Topcase Carrier	'00	'05	For Givi Monokey or Monolock topcases.	Givi F680
R&G Front Axle Sliders	'00	'05	See page 19.	RG.FP0046BK
MRA X-creeen Adjustable Spoiler	'00	'05	Attaches to original windscreen: See page 37.	MRA.XC

Handlebar Risers

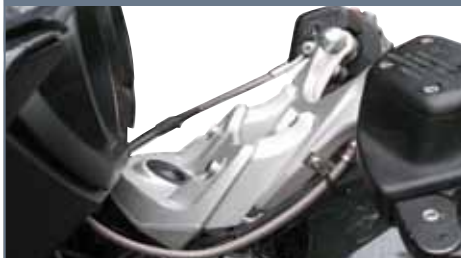

R&G Rear Axle Slider



GPS holder



K1300GT



[See more at TwistedThrottle.com/MyBike](http://TwistedThrottle.com/MyBike)

K1300GT & K1200GT	from	to	Notes	Part Number
Steel Toprack, silver	'06	'12	Accepts TraX, Coocase, & Givi topcases. See page 80.	GPT.07.832.20000.S
QUICK-LOCK EVO Tankring	'06	'08	See page 120.	TRT.00.640.12000.B
QUICK-LOCK EVO Tankring	'09	'12	See page 120.	TRT.00.640.12600.B
QUICK-LOCK GPS Holder	'09	'12	Vibration damped. Black. See page 55.	GPS.07.645.10000.B
Handlebar Risers	'06	'12	Moves bars 1.6" up and 1" back. See page 10.	HEL.HR9017
R&G Frame Sliders	'06	'12	See page 18.	RG.CP0220BL
R&G Bar End Sliders	'06	'08	For K1200GT only. See page 19.	RG.BE0036BK
R&G Rear Axle Sliders	'06	'12	See page 19.	RG.SP0012BK
Kaoko Throttle Lock	'06	'12	See page 16.	KAO.CCF100

ALU-RACK, black



QUICK-LOCK EVO Sidecarrier



Axle Slider: K1300R



K1200R



K1300R

See more at TwistedThrottle.com/MyBike

K1300R, K1200R & K1200R Sport	from	to	Notes	Part Number
ALU-RACK, black	'05	'12	Topcase Adapter not included. See page 82.	GPT.07.411.100.B
QUICK-LOCK EVO Sidecarrier	'05	'12	Sidecase Adapter not included. See page 84.	KFT.07.633.20000.B
QUICK-LOCK EVO Tankring	'05	'08	For K1200R & K1200R Sport See page 120.	TRT.00.640.12000.B
QUICK-LOCK EVO Tankring	'09	'12	See page 120.	TRT.00.640.12600.B
QUICK-LOCK GPS Holder	'05	'12	Vibration damped. Black. See page 55. K1300R, K1200R & K1200R Sport.	GPS.07.646.10400.B
Crashbars, black	'05	'12	See page 4. K1300R, K1200R & K1200R Sport	SBL.07.413.100.B
Centerstand	'05	'08	For K1200R & K1200R Sport only. See page 6.	HPS.07.360.10000.B
Centerstand: K1300R	'09	'12	For K1300R only.	HPS.07.634.10000.B
Mirror Widener	'05	'12	Universal mirror widener. See page 30.	SVL.00.505.102
R&G Frame Sliders	'05	'12	No cutting required: See page 18.	RG.CP0251BL
R&G Front Axle Sliders	'05	'12	See page 19. K1300R, K1200R & K1200R Sport.	RG.FP0046BK
R&G Rear Axle Sliders	'05	'12	See page 19.	RG.SP0012BK
MRA Windscreens	'05	'12	See page 36.	Various



K1300S

See more at TwistedThrottle.com/MyBike

K1300S & K1200S	from	to	Notes	Part Number
ALU-RACK, black	'05	'12	Topcase Adapter not included. See page 82.	GPT.07.361.100.B
QUICK-LOCK EVO Sidecarrier	'05	'12	Sidecase Adapter not included. See page 84.	KFT.07.362.20000.B
QUICK-LOCK EVO Tankring	'05	'08	For K1200S. See page 120.	TRT.00.640.12000.B
QUICK-LOCK EVO Tankring	'09	'11	For K1300S. See page 120	TRT.00.640.12600.B
Centerstand	'05	'08	For K1200S only. See page 6.	HPS.07.360.10000.B
Centerstand	'09	'11	For K1300S only. See page 6.	HPS.07.634.10000.B
Mirror Widener	'05	'12	See page 30.	SVL.07.501.105
R&G Frame Sliders	'09	'12	For K1300S. See page 18.	RG.CP0254BL
R&G Engine Case Cover	'05	'12	For K1200S & K1300S. See page 20.	RG.ECS0004BK
MRA Windscreen	'05	'12	Several shapes available: See page 36.	MRA.07.013

ALU-RACK, black



QUICK-LOCK EVO Sidecarrier



Centerstand



Barkbusters Handguard



Kaoko Throttle Lock



Sidecase Carrier



Givi Sidecase Carrier (shown with TraX case)



Ulysses XB12X

[See more at TwistedThrottle.com/MyBike](http://TwistedThrottle.com/MyBike)

XB9R, XB9SX, XB12R, XB12S, XB12X, & XB12XT	from	to	Notes	Part Number
Topcase Carrier: XB12X	'05	'10	For Givi Monokey or Monolock topcases or TraX topcase with TraX Universal Adapter Plate. Does not interfere with original triple tail.	FHG.7137G
Givi Sidecase Carrier: XB12X	'05	'10	For Givi sidecases or TraX sidecases with TraX Sidecase Adapter kit for Givi	FHG.7138KH
Handlebar Risers	'03	'10	Up and back approximately 2": See page 10.	ROX.3R-P2SSM
Adjustable Windshield Mount	'05	'10		MAD.UJLY-02
Aluminum Flyscreen	'05	'10	Powdercoated satin black	MAD.UJLY-01-FSB-BK
Barkbusters VPS Handguard	'03	'10	See page 12.	BB.BHG6
R&G Front Axle Sliders	'03	'07	For XB12 R / S '03-'07, XB9R '03-'07 See page 19.	RG.FP0022BK
R&G Swingarm Spools	'03	'05	For XB12 R / S '03-'05, XB9R '03-'05 See page 19.	RG.SS0004BK
Kaoko Throttle Lock	'03	'10	See page 16.	KAO.BUB

Spyder Roadster

CAN-AM

Givi Topcase Carrier



Givi PLX Sidecarrier



MRA VarioTouring Windscreen



Spyder Roadster

[See more at TwistedThrottle.com/MyBike](http://TwistedThrottle.com/MyBike)

Can-Am Spyder Roadster	from	to	Notes	Part Number
Givi Topcase Carrier	'08	'12	For Givi Monokey topcases only.	Givi SR770
Givi PLX Sidecarrier	'08	'12	For Givi V35 PLX sidecases only.	Givi PLX770
RAM Accessory Mount	'08	'12	Puts RAM ball on left hand-control mount.	RAM.30.807.10000
Bags-Connection Rear Bags	'08	'12	Several models to choose from: See pages 136-141.	Various
MRA VarioTouring Windscreen	'08	'12	See page 37.	MRA.30.001.VTM
Kaoko Throttle Lock	'08	'12	See page 16.	KAO.CAN100S

Steel Toprack



Barkbusters Lever Guard



MRA VarioTouringScreen Windshield



R&G Fender Eliminator



Handlebar Risers



Crashbars



Multistrada 1200 with Aero Sidecases



[See more at TwistedThrottle.com/MyBike](http://TwistedThrottle.com/MyBike)

QUICK-LOCK EVO Sidecarrier



Multistrada 1200	from	to	Notes	Part Number
Steel Toprack	'10	'12	Accepts several different topcases. See page 80.	GPT.22.139.20001.B
QUICK-LOCK EVO Sidecarrier	'10	'12	See page 84.	KFT.22.140.20000.B
QUICK-LOCK Contour Sidecarrier	'10	'12	For use with Givi V35 sidecases. See page 87.	KFT.22.140.15000.B
QUICK-LOCK EVO Tankring	'10	'12	Fit Adjustment kit required TWT.TRT.00.005.100	TRT.00.640.12600.B
QUICK-LOCK GPS Holder	'10	'12	Vibration damped. Black. See page 55.	GPS.22.646.10000.B
Exhaust Header Guard	'10	'12	Aluminum.	MSS.22.143.10000.S
Crashbar	'10	'12	See page 4.	SBL.22.142.10000.B
Handlebar Risers, black	'10	'12	See page 10.	LEH.22.039.10000.B
Mirror widener	'10	'12	See page 30.	SVL.22.504.10000.B
Centerstand	'10	'12	See page 6.	HPS.22.141.10000.B
Auxiliary Light Mount	'10	'12	For Denali LED lighting see page 64.	NSW.22.004.10001.B
On/Off-road Footpegs	'10	'12	Stainless steel. Silver. See page 34.	FRS.22.011.10000.S
R&G Fender Eliminator	'10	'12	See page 23.	RG.LP0096BK
R&G Engine Case Covers	'10	'12	Left side: See page 20.	RG.ECC0085BK
R&G Engine Case Covers	'10	'12	Right side: See page 20.	RG.ECC0082BK
Barkbusters Lever Guard	'10	'12	Protect your integrated turn signals. Hardened Aluminum spine.	BB.BLG-12
MRA Windscreen	'10	'12	Several shapes available: See page 36.	MRA.23.031

GIVI Topcase Rack



MRA VarioTouringScreen Windscreen



R&G Frame Slider



2005 Multistrada 1100

[See more at TwistedThrottle.com/MyBike](http://TwistedThrottle.com/MyBike)

Multistrada 620, 1000 & 1100	from	to	Notes	Part Number
Mirror Wideners	'03	'10	Extension of mirror turn signal wires may be required on 2006 & later models. See page 30.	SVL.00.504.101
Handlebar Risers	'03	'06	For original 22mm diameter handlebars. See page 10.	LEH.00.039150
Handlebar Risers	'07	'10	Provides 1.3" rise for 28mm diameter original handlebars. See page 10.	GM.D100
Givi Topcase Carrier	'03	'05	For Givi Monokey topcases only.	Givi SR310
Givi topcase Carrier	'06	'09	For Givi Monokey topcases only.	Givi SR311
R&G Bar End Sliders	'99	'09	1000DS '99-'07, 1100DS '07-'09. See page 19.	RG.BE0020BK
R&G Engine Case Cover	'07	'09	1100: Dry Clutch. See page 20.	RG.ECC0012BK
R&G Frame Sliders	'07		Including '07 S4RS, 1100 '07, Super Classic 1000S. See page 18.	Various
Fenda Extenda			Ducati Multistrada 1000DS & 620DS, '06 & Multistrada 1100, '07 & Later.	PP.05510
MRA Windscreen	'03	'10	Several shapes available: See page 36.	MRA.23.019
Barkbusters Handguards	'07	'10	See page 12.	BB.S4

1198, 1098, 848, & Streetfighter

R&G Radiator & Oil Cooler Guard Set



R&G Fender Eliminator



R&G Engine Case Slider



R&G Front Axle Slider



Streetfighter S

1098

[See more at TwistedThrottle.com/MyBike](http://TwistedThrottle.com/MyBike)

Streetfighter	from	to	Notes	Part Number
R&G Fender Eliminator	'09	'12	See page 23.	RG.LP0081BK
R&G Bar End Sliders	'09	'12	See page 19.	RG.BE0048BK
R&G Frame Sliders	'09	'12	See page 18.	RG.CP0253
R&G Engine Case Sliders	'09	'12	See page 20.	RG.ECS0049BK
R&G Radiator & Oil Cooler Guard Set	'09	'12	See page 20.	RG.RAD9016
1198, 1098, 848	from	to	Notes	Part Number
QUICK-LOCK EVO Tankring	'07	'12	Fits 1098 & 1198. See page 120.	TRT.00.640.11000.B
R&G Fender Eliminator		'12	See page 23.	RG.LP0041BK
R&G Bike Protection		'12	Engine, fork, and axle guards. See pages 18-23.	Various



2010 Ducati Hypermotard 1100 EVO SP

[See more at TwistedThrottle.com/MyBike](http://TwistedThrottle.com/MyBike)

Hypermotard	from	to	Notes	Part Number
Blaze Sport Saddlebags	'07	'11	QUICK-LOCK, Nylon, Black. See page 88.	HTA.84.807.100
MFW Vario Footpeg Mount	'07	'11	Rider option available See page 32.	MFW.051.03.05.10
R&G Engine Case Sliders	'07	'11	See page 20.	RG.ECS0049BK
R&G Frame Sliders	'07	'11	See page 18.	Various
R&G Swingarm Spools	'07	'11	See page 19.	RG.SS0006BK
R&G Front Axle Sliders	07'	'11	See page 19.	RG.FP0020BK
R&G Fender Eliminator	'07	'11	See page 23.	RG.LP0054BK
MRA Highway Shield	'07	'11	See page 40.	MRA.HI

R&G Fender Eliminator



R&G Front Axle Slider



R&G Spindle Slider



2011 Ducati Monster 796

[See more at TwistedThrottle.com/MyBike](http://TwistedThrottle.com/MyBike)

Monster (2000 & Later)	from	to	Notes	Part Number
QUICK-LOCK EVO Tankring	'09	'12	Monster 1100 & Monster 696. Spider tankring. No drilling required. See page 120.	TRT.00.640.20300.B
Handlebar Risers	'02	'11	For 22mm diameter handlebars on 620, 695, 750 & 900. See page 10.	GM.D103
Handlebar Risers	'05	'11	For 28mm diameter handlebars on S2R & S4R.	GM.D100
MFW Vario Footpeg Mount	'06		for Monster 696 '06- & many other Monsters	MFW.051.03.01.30
R&G Fender Eliminator	'08	'11	For 696 '08-'11, 1100S '09-, 1100 '09-'12. See page 23.	RG.LP0097BK
R&G Bar End Sliders	'08	'10	For 696.	RG.BE0042BK
R&G Bar End Sliders	'09	'11	1100 models. See page 19.	RG.BE0048BK
R&G Frame Sliders	'08	'11	For 696 '08-'11, 1100S '09-'11. See page 18.	Various
R&G Engine Case Cover	'02	'11	See page 20.	Various
MRA Windscreen	'00	'11	Several shapes available. See page 36.	Various
Kaoko Throttle Lock	'04	'11	See page 16.	KAO.DUCST

QUICK-LOCK EVO Tankring



R&G Aero Frame Slider



R&G Fender Eliminator



R&G Bar End Sliders



Crashbars, black



CBR125R



[See more at TwistedThrottle.com/MyBike](http://TwistedThrottle.com/MyBike)

ALU-RACK



CBR125	from	to	Notes	Part Number
ALU-RACK	'07	'10	See page 82.	GPT.01.323.100.B
Crashbars, black	'04	'10	See page 4.	SBL.01.324.100
R&G Bar End Sliders	'04	'10	See page 19.	RG.BE0034BK
R&G Frame Sliders	'11	'12	See page 18.	RG.CP0281BL
R&G Fender Eliminator	'11	'12	See page 23.	RG.LP0105BK
MRA X-screen Spoiler	'04	'10	Add-on variable blade. See page 37.	MRA.XC
Fenda Extenda	'07	'10		PP.051025

ALU-RACK

In development



R&G Radiator Guard



Coocase Topcase



CBR250R



[See more at TwistedThrottle.com/MyBike](http://TwistedThrottle.com/MyBike)

CBR250R	from	to	Notes	Part Number
R&G Front Axle Sliders	'11	'12	See page 19.	RG.FP0104BK
R&G Frame Sliders	'11	'12	See page 18.	RG.CP0285.BL
R&G Radiator Guard	'11	'12	See page 20.	RAD0104BK
R&G Swingarm Spools	'11	'12	See page 19.	RG.CR0039BK
R&G Exhaust Hanger	'11	'12	See page 21.	RG.EH0049BK
Fenda Extenda	'11	'12	Provides extra protection for your radiator and engine.	PP.051025
MRA Windscreen	'11	'12	Double Bubble RacingScreen. See page 36.	MRA.01.067.R



CRF230L

[See more at TwistedThrottle.com/MyBike](http://TwistedThrottle.com/MyBike)

CRF230L & CRF230M	from	to	Notes	Part Number
Handlebar Riser and Barbacks	'08	'11	See page 10.	Various
Mirror Widener	'08	'11	See page 30.	SVL.00.505.101
Barkbusters VPS Handguards	'08	'11	See page 12.	BB.BHG6
MRA Windscreen	'08	'11	Several shapes available: See page 36.	Various

Barkbusters VPS Handguards



Handlebar risers



ALU-RACK, black



QUICK-LOCK Sidecarrier



Crashbars, black



Blaze Sport Saddlebags



CBF600SA



[See more at TwistedThrottle.com/MyBike](http://TwistedThrottle.com/MyBike)

CBF600SA (2010 & Later)	from	to	Notes	Part Number
ALU-RACK, black	'08	'11	Topcase Adapter not included. See page 82.	GPT.01.277.101
QUICK-LOCK Sidecarrier	'08	'11	Sidecase Adapter not included. See page 84.	KFT.01.278.200
QUICK-LOCK Contour Carrier	'08	'11	For Givi V36 PLX sidecases only. See page 87.	KFT.01.278.150
QUICK-LOCK EVO Tankring	'08	'11	See page 120.	TRT.00.640.10600.B
Blaze Sport Saddlebags	'07	'11	QUICK-LOCK, Nylon, Black. See page 88.	HTA.01.740.10200
Crashbars, black	'08	'11	See page 4.	SBL.01.535.100
Handlebar Riser and Barbacks	'08	'11	See page 10.	Various
Barkbusters Handguards.	'07	'11	See page 12.	BB.S1
MFV Vario Footpeg	'07	'11	See page 32	MFV.051.04.01.00

QUICK-Lock Sidecarrier mounting points



Adjustable Footpegs



Mirror Widener



CBR600F



See more at TwistedThrottle.com/MyBike

CBR600F & CBR600F4i	from	to	Notes	Part Number
QUICK-LOCK Sidecarrier	'99	'08	Only fits models with passenger grab handle. See page 84.	KFT.01.027.100
QUICK-LOCK EVO Tankring	'03	'03	See page 120.	TRT.00.640.10600.B
Mirror Widener	'99	'08	See page 30.	SVL.01.500.100
Handlebar Risers	'99	'08	See page 10.	GM.H120
R&G Front Axle Sliders	'99	'08	Not RR models.	RG.FP0010BK
MFW Adjustable Footpegs	'87	'11	Rider and passenger mounts available. See page 32.	Various
MRA Windscreen	'01	'08	Several shapes available: See page 36.	MRA.01.015

See more at TwistedThrottle.com/MyBike



2009 CBR600RR

MRA Double Bubble RacingScreen



R&G Frame Slider

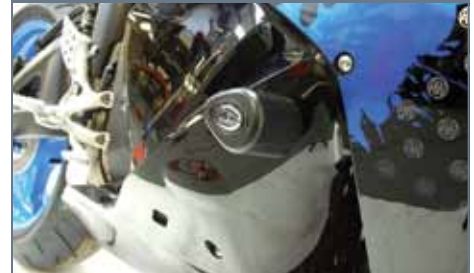

R&G Bar End Slider



CBR600RR	from	to	Notes	Part Number
QUICK-LOCK EVO Tankring	'03	'11	See page 120.	TRT.00.640.10600.B
Blaze Sport Saddlebags	'07	'11	QUICK-LOCK, Nylon, Black. See page 88.	HTA.01.740.10000
Mirror Widener	'03	'11	See page 30.	SVL.00.503.100
R&G Frame Sliders	'09	'11	"Aero" shape. See page 18	RG.CP0245.BL
R&G Frame Sliders	'07	'08	"Aero" shape. See page 18	RG.CP0199.BL
R&G Frame Sliders	'03	'06	"Classic" shape. See page 18.	RG.CP0099BL
R&G Bar End Sliders	'03	'11	See page 19.	RG.BE0007BK
Bags-Connection Rear Bags	'03	'11	Several models to choose from. See page 136-141.	Various
MRA Windscreen	'03	'11	Several shapes available: See page 36.	Various

VT750C2 Shadow



[See more at TwistedThrottle.com/MyBike](http://TwistedThrottle.com/MyBike)

All Shadow Models	from	to	Notes	Part Number
Handlebar Risers	'97	'10	For all Shadow & VTX1300 models with 1" diameter handlebars. See page 10.	GM.H121
Centerstand	'00	'08	For VT600C Shadow VLX. See page 6.	HPS.01.106.100
Centerstand	'97	'04	For VT750 C2 Shadow Ace, RC44. See page 6.	HPS.01.049.100
Centerstand	'00	'08	For VT750DC Black Widow / Shadow Spirit, RC48 only Not for VT750C2 Shadow Spirit models, '07-'08. See page 6.	HPS.01.329.100
MRA Windscreen	'97	'11	Several shapes available: See page 36.	Various

Touring Windscreen



Rear Luggage Rack and Topcase



MRA X-creen Windscreen



Silverwing 600



[See more at TwistedThrottle.com/MyBike](http://TwistedThrottle.com/MyBike)

Silverwing 600	from	to	Notes	Part Number
Luggage Rack	'01	'11	For Givi Monokey topcases only.	Givi SR19
Luggage Rack	'01	'11	For Givi Monolock topcases only.	Givi SR19M
Mirror Widener	'01	'11	Universal Mirror Widener. See page 30.	SVL.00.505.101
Backrest	'01	'11	For use with or without luggage rack & topcase.	Givi TB19
MRA X-creen Spoiler	'01	'11	See page 37.	MRA.XC
Touring Windscreen	'01	'11	26.5"h x 23.5"w - Clear tint.	Givi D214ST
Kaoko Throttle Lock	'01	'11	See page 16.	KAO.HNDFJS
Saddlebags	'01	'11	10"x18"x13". 36-liter volume - Includes Rain Cover.	Givi T449



XL600V Transalp

[See more at TwistedThrottle.com/MyBike](http://TwistedThrottle.com/MyBike)

Crashbars, black



Skid Plate & Centerstand



XL600V Transalp	from	to	Notes	Part Number
Skid Plate	'89	'00	Aluminum. See page 7.	MSS.01.016.100
Handlebar Riser and Barbacs	'89	'99	See page 10. (LEH.00.039.150 or LEH.00.039.152)	Various
Crashbars, black	'89	'93	Additional M8x130 hex screw & lock nut for North American model sold separately. See page 4.	Givi TN363
Barkbusters VPS Handguards	'89	'99	See page 12.	BB.BHG6
XL650V Transalp	from	to	Notes	Part Number
Steel Toprack	'00	'06	Accepts several different topcases. See page 80.	GPT.01.336.20001.B
XL700V Transalp	from	to	Notes	Part Number
Steel Toprack	'08	'12	Accepts several different topcases. See page 80.	GPT.01.465.20001.B



2010 XR650L



Learn more about this special XR650!

[See more at TwistedThrottle.com/MyBike](http://TwistedThrottle.com/MyBike)

XR650L & XR650R	from	to	Notes	Part Number
Steel Toprack	'94	'12	Accepts, TraX, Coocase, & Givi Topcases. See page 80.	GPT.01.825.20000.B
EVO Sidecarrier	'93	'12	Hard-bolted for added durability off-road.	KFT.01.826.20000.B
Sub-frame Reinforcement Kit	'93	'12	Bolt-on solution. No cutting or welding required.	FRM.01.824.10000.B
Handlebar Riser and Barbacs	'93	'12	LEH.00.039.150 or LEH.00.039.152 See page 10.	Various
RotoPax Fuel Cell	'93	'12	1 gallon fuel capacity. See page 102.	RX.1G
RotoPax Water Cell	'93	'12	1 gallon water capacity. See page 102.	RX.1W
Barkbusters VPS Handguards	'93	'12	See page 12.	BB.BHG1
R&G Swingarm Sliders/Spools	'93	'12	See page 19.	RG.SP0003BK
R&G Toe Chain Guard, black	'93	'12	See page 22.	RG.TG0005BK
MRA Windscreen	'93	'12	Several shapes available: See page 36.	Various

Steel Toprack



Handlebar Risers

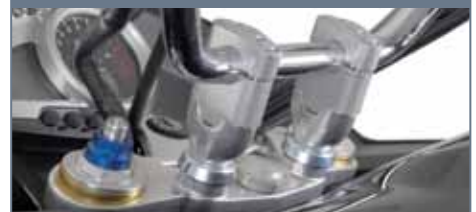

Subframe Reinforcement Kit



EVO Sidecarriers



Topcase carrier (shown with case)



PLX sidecarrier (shown with cases)



Windscreen



2009 DN-01

See more at TwistedThrottle.com/MyBike

DN-01	from	to	Notes	Part Number
Mirror Widener	'09	'11	See page 30.	SVL.00.505.101
Handlebar Riser and Barbacks	'09	'11	See page 10.	Various
Givi Topcase Carrier	'09	'11	For Givi Monokey or Monolock topcases only.	Givi FZ265
Givi PLX Sidecarrier	'09	'11	For Givi V35 PLX sidecases only.	Givi PLX204
Windscreen	'09	'11	18"h x 26"w. Clear .	Givi D316S

ALU-RACK, black



GPS Holder



Mirror Widener



NT700V Deauville

See more at TwistedThrottle.com/MyBike

NT700V Deauville	from	to	Notes	Part Number
ALU-RACK, black	'06	'12	Topcase Adapter not included. See page 82.	GPT.01.615.100.B
QUICK-LOCK EVO Tankring	'06	'12	See page 120.	TRT.00.640.10600.B
QUICK-LOCK GPS Holder	'06	'12	Vibration damped. Black. See page 55.	GPS.00.646.10200.B
Mirror Widener	'06	'12	See page 30.	SVL.01.501.11100.B
Handlebar Riser and Barbacks	'06	'12	See page 10.	Various
Kaoko Throttle Lock	'06	'12	Cruse Control See page 16.	KAO.HNDNT
MFW Adjustable Footpegs	'06	'12	Vario mount Rider pegs. See page 32.	MFW.051.04.01.00
MRA Windscreen	'06	'12	See page 36.	Various



VFR800 VTEC Interceptor

See more at TwistedThrottle.com/MyBike

VFR800 VTEC (2002 & Later)	from	to	Notes	Part Number
ALU-RACK, black	'02	'11	Topcase Adapter not included. See page 82.	GPT.01.208.100
QUICK-LOCK Sidecarrier	'02	'11	Sidecase Adapter not included.	KFT.01.134.100
QUICK-LOCK Contour Carrier	'02	'11	For Givi V35 PLX sidecases only. See page 87.	KFT.01.134.150
QUICK-LOCK EVO Tankring	'02	'11	See page 120.	TRT.00.640.10600.B
Mirror Widener	'02	'11	See page 30.	SVL.01.500.100
Handlebar Riser	'02	'11	See page 10.	GM.H112
R&G Frame Sliders	'02	'11	Cutting required: See page 18.	RG.CP0073.BL
R&G Bar End Sliders	'02	'11	See page 19.	RG.BE0007BK
MRA Windscreen	'02	'11	Several shapes available: See page 36.	MRA.01.035

ALU-RACK, black



QUICK-LOCK Contour Carrier mounting points



Frame Slider



Mirror Wideners



919



See more at TwistedThrottle.com/MyBike

919 / CB900 Hornet	from	to	Notes	Part Number
ALU-RACK, black	'02	'07	Topcase Adapter not included. See page 82.	GPT.01.131.100.B
QUICK-LOCK Sidecarrier	'02	'07	Sidecase Adapter not included.	KFT.01.114.100
QUICK-LOCK EVO Tankring	'02	'07	See page 120.	TRT.00.640.10600.B
Centerstand	'02	'07	See page 6.	HPS.01.109.100
Crashbars, black	'02	'07	See page 4.	SBL.01.113.100
Mirror Widener	'02	'07	See page 30.	SVL.00.505.101
Handlebar Riser and Barbacks	'02	'07	See page 10. (LEH.00.039.150 or LEH.00.039.152)	Various
R&G Frame Sliders	'02	'07	No cutting required: See page 18.	RG.CP0055BL
R&G Bar End Sliders	'02	'07	See page 19.	RG.BE0007BK
R&G Toe Chain Guard	'02	'07	See page 22.	RG.TG0001.BK

QUICK-LOCK Sidecarrier mounting points



Crashbar



Centerstand



ALU-RACK, black



R&G Axle Slider



R&G Engine Case Slider



MRA RacingScreen



R&G Fender Eliminator



CB1000R

[See more at TwistedThrottle.com/MyBike](http://TwistedThrottle.com/MyBike)

CB1000R	from	to	Notes	Part Number
ALU-RACK , black	'08	'11	Black. For QUICK-LOCK Adapter Plate. See page 82.	GPT.01.462.100.B
Blaze Sport Saddlebags	'08	'11	QUICK-LOCK, Nylon, Black. See page 88.	HTA.01.740.10100
QUICK-LOCK EVO Tankring	'08	'11	See page 120.	TRT.00.640.10600.B
QUICK-LOCK GPS Holder	'08	'11	Vibration damped. Black. See page 55.	GPS.01.646.10300.B
Crashbar	'08	'11	Black. See page 4.	SBL.01.461.100
Mirror Wideners	'08	'11	Universal. Black. See page 30.	SVL.00.505.101
R&G Axle Sliders	'08	'11	Black, Pair. See page 19.	RG.FP0086BK
R&G Engine Case Slider	'08	'11	Black, right side only. Left cover sold separately.	RG.ECS0036BK
R&G Fender Eliminator	'08	'11	Black. See page 23.	RG.LP0074BK
R&G Bar End Sliders	'08	'11	Pair. See page 19.	RG.BE0007BK
R&G Engine Case Cover	'08	'11	Black, right side only. Left cover sold separately. See page 20.	RG.ECC0024BK
MRA RacingScreen	'08	'11	Requires MRA.HK mounting kit. See page 39.	MRA.RNB

QUICK-LOCK EVO Sidecarrier mounting points



Crashbars, black



ALU-RACK, black



CBF1000

[See more at TwistedThrottle.com/MyBike](http://TwistedThrottle.com/MyBike)

CBF1000	from	to	Notes	Part Number
ALU-RACK, black	'06	'09	Topcase Adapter not included. See page 82.	GPT.01.277.101.B
ALU-RACK, black	'10	'12	Topcase Adapter not included. See page 82.	GPT.01.731.10000.B
QUICK-LOCK EVO Sidecarrier	'06	'09	Fits multiple luggage: Sidecase Adapter not included. See page 84.	KFT.01.278.200
QUICK-LOCK Contour Carrier	'06	'09	For Givi V35 PLX sidecases only. See page 87.	KFT.01.278.150
QUICK-LOCK EVO Sidecarrier	'10	'12	Fits multiple luggage: Sidecase Adapter not included. See page 84.	KFT.01.730.20000
QUICK-LOCK Contour Carrier	'10	'12	For Givi V35 PLX sidecases only. See page 87.	KFT.01.730.15000
Blaze Sport Saddlebags	'06	'12	QUICK-LOCK, Nylon, Black. See page 88.	HTA.01.740.10200
Crashbars, black	'06	'09	See page 4.	SBL.01.215.100
SW-MOTECH Frame Sliders	'10	'12	See page 28.	STP.01.590.10101
MRA Windscreen	'06	'12	Several shapes available: See page 36.	Various



2009 CBR1000RR

[See more at TwistedThrottle.com/MyBike](http://TwistedThrottle.com/MyBike)

CBR1000RR Fireblade	from	to	Notes	Part Number
QUICK-LOCK EVO Tankring	'04	'11	See page 120.	TRT.00.640.10600.B
Mirror Widener	'04	'11	See page 30.	SVL.00.503.100
R&G Frame Sliders	'08	'12	No cutting required: See page 18.	RG.CP0228.BL
Kaoko Throttle Lock	'04	'12	See page 16.	Various
MFW Adjustable Footpegs	'04	'11	Rider and passenger mounts available. See page 32.	MFW.051.04.01
R&G Engine Case Covers	'04	'12	Several models to choose from: See page 20.	Various
MRA Windscreen	'04	'11	Several shapes available: See page 36.	MRA.01.062

R&G Engine Case Cover



R&G Frame Slider



View our Varadero demo bike video.



2010 XL1000V Varadero

[See more at TwistedThrottle.com/MyBike](http://TwistedThrottle.com/MyBike)

XL1000V Varadero	from	to	Notes	Part Number
Adventure Kit	'08	'12	Crashbars, carriers, adapters and TraX cases.	TT.01C
Steel Toprack	'98	'07	Accepts TraX, CooCase, & Givi Topcases. See page 80.	GPT.01.625.20001
Steel Toprack	'08	'12	Accepts TraX, CooCase, & Givi Topcases. See page 80	GPT.01.625.20001
QUICK-LOCK EVO Sidecarrier	'08	'12	Sidecase Adapter not included. See page 84.	KFT.01.624.200
QUICK-LOCK Contour Carrier	'08	'12	For Givi V35 PLX sidecases only. See page 87.	KFT.01.624.150
QUICK-LOCK EVO Tankring	'08	'12	See page 120.	TRT.00.640.10600.B
QUICK-LOCK GPS Holder	'08	'12	Vibration damped. Black. See page 55.	GPS.01.646.10000.B
Crashbars, black	'08	'12	See page 4.	SBL.01.322.100
Skid Plate	'08	'12	Aluminum. See page 7.	MSS.01.811.10000
Centerstand	'08	'12	See page 6.	HPS.01.223.100
Handlebar Riser and Barbacks	'08	'12	See page 10.	Various
Auxiliary Light Mounts	'08	'12	For Denali LED lighting see page 64.	LAH.01.818.10000
On/Off-road Footpegs	'08	'12	Stainless steel. Silver. See page 34.	FRS.01.011.10400
Kaoko Throttle Lock	'08	'12	2 models (with or without handguards) See page 16.	Various
MRA VarioTouring Windscreen	'08	'12	See page 37.	Various
Barkbusters VPS Handguards	'08	'12	See page 12.	BB.BHG31

Kaoko Throttle Lock & Barkbusters Handguards



Skid Plate



Crashbars, black



Centerstand



ALU-RACK, black



QUICK-LOCK EVO Sidecarrier mounting points



CBR1100XX Blackbird

[See more at TwistedThrottle.com/MyBike](http://TwistedThrottle.com/MyBike)

CBR1100XX Blackbird	from	to	Notes	Part Number
ALU-RACK, black	'96	'07	Topcase Adapter not included. See page 82.	GPT.01.207.100.B
QUICK-LOCK EVO Sidecarrier	'96	'07	Sidecase Adapter not included. See page 84.	KFT.01.061.20000.B
QUICK-LOCK EVO Tankring	'96	'07	See page 120.	TRT.00.640.10600.B
Mirror Widener	'96	'07	See page 30.	SVL.01.501.104
Handlebar Risers	'96	'07	See page 10.	GM.H112
R&G Frame Sliders	'96	'07	See page 18.	RG.CP0071.BL
MRA Windscreen	'96	'07	Several shapes available: See page 36.	MRA.01.048

ALU-RACK, black



QUICK-LOCK Sidecarrier mounting points



VFR1200F

[See more at TwistedThrottle.com/MyBike](http://TwistedThrottle.com/MyBike)

VFR1200F	from	to	Notes	Part Number
ALU-RACK, black	'10	'12	Topcase Adapter not included. See page 82.	GPT.01.723.10000
QUICK-LOCK EVO Sidecarrier	'10	'12	Sidecase Adapter not included. See page 84.	KFT.01.724.20000.B
QUICK-LOCK Contour Carrier	'10	'12	For Givi V35 PLX sidecases only. See page 87.	KFT.01.724.15000.B
QUICK-LOCK EVO Tankring	'10	'12	See page 120.	TRT.00.640.10600.B
Centerstand	'10	'12	See page 6.	HPS.01.729.10000.B
Mirror Widener	'10	'12	See page 30.	SVL.01.501.10600
R&G Frame Sliders	'10	'12	Aero style. See page 18.	RG.CP0265BL

Steel Toprack



Handlebar Risers



ST1300

[See more at TwistedThrottle.com/MyBike](http://TwistedThrottle.com/MyBike)

ST1300	from	to	Notes	Part Number
Steel Toprack	'02	'11	Accepts TraX, Coocase, & Givi Topcases. See page 80.	GPT.01.814.20000.S
QUICK-LOCK EVO Tankring	'02	'11	See page 120.	TRT.00.640.10600.B
Auxiliary Light Mount	'02	'11	6mm fender mount kit.	TT-D1.020.M6
Handlebar Riser	'02	'11	Raises bars 32mm up and 25mm back. See page 10.	GM.H101
Kaoko Throttle Lock	'02	'11	See page 16.	KAO.HNDST
MFW Adjustable Footpegs	'02	'11	Rider and passenger mounts available. See page 32.	MFW.051.04.01



KLX 250S

[See more at TwistedThrottle.com/MyBike](http://TwistedThrottle.com/MyBike)

Skid Plate



Radiator Guard, silver



Rear Rack for QUICK-LOCK Tankbags



KLX250S & KLX250SF (2008 & Later)	from	to	Notes	Part Number
Rear Rack for QUICK-LOCK Tankbags	'08	'12	For use only with Bags-Connection QUICK-LOCK Tankbags. Includes tankring.	GTH.08.428.100.TWT
Bags-Connection Micro	'08	'12	See page 128.	BC.TRS.00.110.20000
Bags-Connection Daypack	'08	'12	See page 129.	BC.TRS.00.108.20000
Bags-Connection Sport	'08	'12	See page 127.	BC.TRS.00.101.20000
Skid Plate	'08	'12	Aluminum. See page 7.	MSS.08.425.10000.S
Radiator Guard, silver	'08	'12	See page 9.	KLS.08.426.10000.S
Handlebar Risers & Barbacks	'08	'12	See page 10 (LEH.00.039.150 or LEH.00.039.152).	Various
Mirror Widener	'08	'12	Universal Mirror Extensions: See page 30.	SVL.00.505.101
Barkbusters VPS Handguards	'08	'12	See page 12.	BB.BHG6
MRA Windscreen	'08	'12	Several shapes available: See page 36.	Various

[See more at TwistedThrottle.com/MyBike](http://TwistedThrottle.com/MyBike)



Super Sherpa 250

Barkbusters VPS Handguards



Handlebar Risers & Barbacks, black or silver



Super Sherpa 250	from	to	Notes	Part Number
Handlebar Risers & Barbacks	'99	'10	Black & silver available. See page 10.	LEH.00.039.152
Mirror Widener	'99	'10	Universal Mirror Extensions: See page 30.	SVL.00.505.101
GPS Handlebar Mount	'99	'10	7/8" (22mm) up to 1 1/4" (32mm), black, silver or chrome. See page 53.	TM.30912
Barkbusters VPS Handguards	'99	'10	See page 12.	BB.BHG6
MRA Windscreen	'99	'10	Several windscreen shapes available: See page 36.	Various

ALU-RACK, '08 - '11 models



ALU-RACK, black ('87 - '07 models)



Mirror Wideners



Ninja 250R

[See more at TwistedThrottle.com/MyBike](http://TwistedThrottle.com/MyBike)

Ninja 250R	from	to	Notes	Part Number
ALU-RACK, black	'87	'07	Does not fit '00-'07 EX250-H Canadian model. See page 82.	GPT.08.819.10000.B
ALU-RACK, black	'08	'12	Topcase Adapter not included. See page 82.	GPT.08.820.10000.B
QUICK-LOCK EVO Tankring	'86	'07	See page 120.	TRT.00.640.13500.B
QUICK-LOCK EVO Tankring	'08	'12	See page 120.	TRT.00.640.11600.B
Handlebar Risers	'87	'07	See page 10.	GM.K108
Mirror Wideners	'08	'12	See page 30.	SVL.08.500.100
R&G Bar End Sliders	'08	'12	See page 19.	RG.BE0015BK
R&G Fender Eliminator	'08	'12	See page 23.	RG.LP0071BK
MRA Windscreen	'08	'12	Several shapes available: See pages 36.	MRA.08.054

R&G Bar End Slider



Givi Toprack and Topcase



R&G Frame Slider



Mirror Widener



1994 Ninja 500R

[See more at TwistedThrottle.com/MyBike](http://TwistedThrottle.com/MyBike)

Ninja 500R	from	to	Notes	Part Number
QUICK-LOCK EVO Tankring	'87	'08	See page 120	TRT.00.640.13500.B
QUICK-LOCK EVO Tankring	'08	'12	See page 120	TRT.00.640.11600.B
Givi Toprack	'94	'12		Givi F425
Mirror Widener	'87	'93	See page 30.	SVL.08.501.108
Mirror Widener	'94	'12	See page 30.	SVL.08.500.100
R&G Frame Sliders	'87	'12	See page 18.	RG.CP0180BL
R&G Bar End Sliders	'87	'12	See page 19.	RG.BE0001BK
MRA Windscreen	'87	'93	Several shapes available: See page 36.	MRA.08.002
MRA Windscreen	'94	'12	Several shapes available: See page 36.	MRA.08.003



ZX6R

[See more at TwistedThrottle.com/MyBike](http://TwistedThrottle.com/MyBike)

ZX6R & ZZR600	from	to	Notes	Part Number
Blaze Sport Saddlebags	'08	'11	QUICK-LOCK, Nylon, Black. See page 88. Fits ZX6R only.	HTA.08.740.10100
QUICK-LOCK EVO Tankring	'95	'04	See page 120.	TRT.00.640.14000.B
QUICK-LOCK EVO Tankring	'08	'12	See page 120.	TRT.00.640.14000.B
Handlebar Risers	'95	'97	See page 10.	GM.K110
Mirror Widener	'95	'11	See pages 30.	Various
R&G Frame Sliders	'07	'11	Fairing trimming required for installation. See page 18.	RG.CP0204
R&G Fender Eliminator	'07	'11	Fender Eliminator See page 23.	RG.LP0047BK
Kaoko Throttle Lock	'95	'11	Replaces 17mm bar end weights ONLY. See page 16.	KAO.KAW400
MRA Windscreen	'95	'11	Several shapes available: See pages 36.	Various



R&G Aero Frame Slider



MRA Double Bubble RacingScreen



R&G Fender Eliminator

ER-6n & Ninja 650R (2006-2008)



Ninja 650R



ER-6n

[See more at TwistedThrottle.com/MyBike](http://TwistedThrottle.com/MyBike)

ER-6n & Ninja 650R (2006-2008)	from	to	Notes	Part Number
ALU-RACK, black	'06	'08	Topcase Adapter not included. See page 82.	GPT.08.391.100BR01
QUICK-LOCK EVO Sidecarrier	'06	'08	Sidecase Adapter not included. See page 84.	KFT.08.477.200
QUICK-LOCK EVO Tankring	'06	'12	See page 120.	TRT.00.640.14000.B
Handlebar Risers & Barbacks	'06	'08	See page 10.	Various
Mirror Widener	'06	'08	See pages 30.	SVL.08.500.100
MFW Adjustable Footpegs	'06	'11	Rider & passenger mounts available. See page 32.	MFW.051.05.030
R&G Bar End Sliders	'06	'08	See page 19.	RG.BE0001BK
Barkbusters Handguards			See page 16.	BB.S1
Kaoko Throttle Lock	'06	'12	For use with Barkbusters Handguards. See page 12.	KAO.KAW200
MRA Windscreen: Ninja 650R	'06	'08	Several shapes available: See pages 36.	MRA.08.048

ALU-RACK, black



QUICK-LOCK EVO Sidecarrier mounting points



MRA VarioTouring Windscreen



ALU-RACK, black



QUICK-LOCK EVO Sidecarrier



Handlebar Risers



R&G Fender Eliminator



QUICK-LOCK EVO Tankring



R&G Frame Sliders



ER-6f

[See more at TwistedThrottle.com/MyBike](http://www.TwistedThrottle.com/MyBike)



Ninja 650R

Ninja 650R (2009 & Later)	from	to	Notes	Part Number
ALU-RACK, black	'09	'11	Installation of original Kawasaki grab handles required (sold separately). See page 82.	GPT.08.672.10000.B
QUICK-LOCK EVO Sidecarrier	'09	'11	Installation of original Kawasaki grab handles required (sold separately). See page 84.	KFT.08.671.20000.B
QUICK-LOCK EVO Tankring	'09	'11	See page 120.	TRT.00.640.14000.B
QUICK-LOCK GPS Holder	'09	'11	Vibration damped. Black. See page 55.	GPS.08.646.10200.B
Blaze Sport Saddlebags	'09	'11	QUICK-LOCK, Nylon, Black. See page 88.	HTA.08.740.10400
Mirror Widener	'06	'11	See page 30.	SVL.08.500.100
Handlebar Risers	'09	'11	See page 10.	LEH.08.039.120.B
R&G Frame Sliders	'09	'11	Marking kit included for two 9mm holes in the fairings. See page 18.	RG. CP0249.BL
R&G Underbody Slider	'09	'11	Avoid cutting the fairing and protect the frame	RG.UCP0001BL
R&G Bar End Sliders	'09	'11	See page 19.	RG.BE0001BK
R&G Fender Eliminator	'09	'11	See page 23.	RG. LP0080BK
Kaoko Throttle Lock	'09	'11	For use with Barkbusters Handguards. See page 12.	KAO.KBB300
MRA Windscreen	'09	'11	Several shapes available. See page 36.	MRA.08.058

2011 ER-6n



[See more at TwistedThrottle.com/MyBike](http://TwistedThrottle.com/MyBike)

2010 ER-6n



ALU-RACK, black



QUICK-LOCK EVO Sidecarrier



Crashbars, black



GPS Holder



Radiator Guard



R&G Frame Slider



ER-6n (2009 & Later)	from	to	Notes	Part Number
ALU-RACK, black	'09	'11	Installation of original Kawasaki grab handles required (sold separately). See page 82.	GPT.08.672.10000.B
QUICK-LOCK EVO Tankring	'09	'12	See pages 120	TRT.00.640.14000.B
QUICK-LOCK EVO Sidecarrier	'09	'12	Installation of original Kawasaki grab handles required (sold separately). See page 84.	KFT.08.671.20000.B
Blaze Sport Saddlebags	'09	'12	QUICK-LOCK, Nylon, Black. See page 88.	HTA.08.740.10400
Crashbars, black	'09	'12	See page 4.	SBL.08.679.10000.B
R&G Radiator Guard	'09	'12	See page 20.	RG.RAD0091BK
QUICK-LOCK GPS Holder	'09	'12	Vibration damped. Black. See page 55.	GPS.08.646.10200.B
Handlebar Risers & Barbacks	'09	'12	20mm height: See page 10.	LEH.08.039.120.B
Mirror Widener	'09	'12	See page 30.	SVL.00.505.101
R&G Frame Sliders	'09	'12	See page 18.	RG.CP0247BL
R&G Fender Eliminator	'09	'12	See page 23.	RG.LP0080BK
Kaoko Throttle Lock	'09	'12	For use with Barkbusters Handguards. See page 16.	KAO.KBB300
Barbuster Handguards	'09	'12	Fits both ABS & non-ABS models. See page 12.	BB.S7
MRA Windscreen	'09	'12	"RNB" RacingScreen for naked bikes. See page 39.	MRA.RNB

Steel Toprack



QUICK-LOCK EVO Sidecarrier



Crashbar, black



Skid Plate, Aluminum



Centerstand, black



Master Cylinder Guard



Handlebar Risers



1996 KLR650A



[See more at TwistedThrottle.com/MyBike](http://TwistedThrottle.com/MyBike)

KLR650A (2007 & Earlier)	from	to	Notes	Part Number
Steel Toprack	'87	'07	Accepts TraX, Coocase, & Givi Topcases. See page 80.	TWT.GPT.08.010.100
QUICK-LOCK EVO Sidecarrier	'87	'07	Fits multiple luggage racks Sidecase Adapter not included. See page 84.	KFT.08.287.200
Crashbar, black	'87	'07	27mm diameter steel tubing, black. Also fits KLR650B Tengai. See page 4.	SBL.08.274.100
Skid Plate	'87	'07	3mm aluminum. May be used with or without SW-MOTECH crashbar and centerstand.	MSS.08.347.100
Master Cylinder Guard	'87	'07	Black or silver. Protects right side rear brake cylinder.	GRD.00.804.10000
Centerstand	'87	'07	Fits North American KLR650A with original suspension.	HPS.08.321.100
Handlebar Risers & Barbacks	'87	'07	See pages 10 (LEH.00.039150 or LEH.00.039152).	Various
Mirror Wideners	'87	'07	Universal Mirror Extensions: See page 30.	SVL.00.505.101
Mirror Thread Ball M10	'87	'07	M10 x 1.25mm thread. ø 1 inch. For RAM-Arm.	CPA.00.424.115
Left-side mirror mount with choke re-locator	'87	'07	Replaces the original left-side mirror mount (which has a tendency to snap off) with a billet aluminum mirror mount for increased strength.	SVL.08.809.10000.B
Fuse Relocation Harness	'87	'07	Replaces OEM fuses with ATM mini fuses and relocates to easily accessible area.	EC.08106
Voltage Monitor	'87	'07	Flush mount LED keep you apprised of electrical output	EC.04101
Turn Signal to Running/Turn/ Brake Light Harness	'87	'07	Allows use of Turn Signal Conversion Kit (EC.01314) to add running / brake light functionality to turn signals.	EC.08108
Stebel Air Horn Mount	'87	'07	Stebel Air Horn sold separately. See page 71.	TWT-00-013-001
Barkbusters VPS Handguards	'87	'07	See page 12.	BB.BHG6
MRA Windscreens	'87	'07	See page 36.	MRA.08.051
Kaoko Throttle Lock	'87	'07	See page 16.	KAO.SUZ100



View our KLR650e project bike video.



KLR650E



[See more at TwistedThrottle.com/MyBike](http://TwistedThrottle.com/MyBike)

KLR650E (2008 & Later)	from	to	Notes	Part Number
Steel Toprack	'08	'11	Accepts several different topcases. See page 80.	GPT.08.365.20001.B
QUICK-LOCK EVO Sidecarrier	'08	'11	Fits multiple luggage racks Sidecase Adapter not included. See page 84.	KFT.08.363.200
Crashbar	'08	'12	Vibration dampened includes mounting points for auxiliary driving lights and highway pegs. See page 4.	SBL.08.297.10001
Folding Footpeg Mounts	'08	'12	Bolts directly to pre-drilled point on crashbars.	MFW.050.00.10.M10
Skid Plate	'08	'12	3mm aluminum, silver & black finish. See page 7.	MSS.08.347.10001
Master Cylinder Guard	'08	'12	Black or silver. Protects rear brake master cylinder. See page 8.	GRD.00.804.10000
Centerstand	'08	'12	Includes lifting handle. See page 6.	HPS.08.364.100
Shortened Sidestand	'08	'12	Fits bikes with lowered suspension.	STS.08.810.10000.B
Handlebar Risers & Barbacks	'08	'12	See pages 10 (LEH.00.039.150 or LEH.00.039.152).	Various
Mirror Wideners	'08	'12	Requires (2) TT.SVL.05.101 spacer kits. See page 30.	SVL.00.505.101
Auxiliary Light Mount	'08	'12	For Denali LED lighting: See page 64.	TWT.LAH.08.003.100
Stebel Air Horn Mounting Kit	'08	'12	Stebel Air Horn sold separately. See page 71.	TWT.HMT.08.004.100
Turn Signal to Running/Turn/Brake Light Harness	'08	'12	Allows use of Turn Signal Conversion Kit (EC.01314) to add running / brake light functionality to turn signals.	EC.01319
Kaoko Throttle Lock	'08	'12	For use WITHOUT Barkbusters Handguards. See page 16.	KAO.KAW200
Kaoko Throttle Lock	'08	'12	For use with Barkbusters Handguards. See page 16.	KAO.KBB300
Barkbusters VPS Handguards	'08	'12	See page 12.	BB.BHG6
Barkbusters Storm Handguards	'08	'12	See page 12.	BB.S4
MRA Windscreens	'08	'12	Several shapes available: See page 36.	MRA.08.052

* Components shown in yellow are custom painted for Twisted Throttle demo bikes. Items for sale are black.

Steel Toprack



QUICK-LOCK EVO Sidecarrier



Crashbars, black



Kaoko Throttle Lock (KAO.KAW200)



Aluminum Skid Plate



Centerstand



Lifting Handle for Centerstand



Master Cylinder Guard, black or silver



ALU-RACK, black



QUICK-LOCK Sidecarrier mounting points



Crashbars, black



Fenda Extenda



R&G Front Axle Slider



GPS Holder



VarioTouringScreen Windshield



2008 Versys 650



2007 Versys 650



[See more at TwistedThrottle.com/MyBike](http://TwistedThrottle.com/MyBike)

Versys 650 (2009 & Earlier)	from	to	Notes	Part Number
ALU-RACK, black	'07	'09	Topcase Adapter not included. See page 82.	GPT.08.391.100BR01
QUICK-LOCK EVO Sidecarrier	'07	'09	Sidecase Adapter not included. See page 84.	KFT.08.725.20000.B
QUICK-LOCK Contour Carrier	'07	'09	For Givi V35 PLX sidecases only. See page 87.	KFT.08.725.15000.B
QUICK-LOCK EVO Tankring	'07	'09	See page 120.	TRT.00.640.14000.B
QUICK-LOCK GPS Holder	'07	'09	Vibration damped. Black. See page 55.	GPS.08.646.10000.B
Crashbar	'07	'09	See page 4.	SBL.08.508.100
Skid Plate	'07	'09	Aluminum, see page 7.	MSS.08.712.10000.B
Mirror Widener	'07	'09	See page 30.	SVL.00.505.101
Handlebar Risers, silver	'07	'09	18mm (0.7") rise: See page 10.	LEH.08.039.119.S
Auxiliary Light Mount	'07	'09	Mounts under front fairing. See page 64 for Denali LED lighting.	NSW.08.004.10100
Barkbusters VPS Handguards	'07	'09	See page 12.	BB.BHG-VER
R&G Front Axle Sliders	'07	'09	See page 19.	RG.FP0059BK
MRA Windscreens	'07	'09	Several shapes available: See page 36.	MRA.08.053
Fenda Extenda	'07	'09		PP.053420

2010 Versys 650



See more at TwistedThrottle.com/MyBike

R&G Axle Slider



SW-MOTECH Skid Plate



Barbuster Handguards



Versys 650 (2010 & Later)	from	to	Notes	Part Number
ALU-RACK, black	'10	'12	Topcase Adapter not included. See page 82.	GPT.08.714.10000.B
QUICK-LOCK EVO Sidecarrier	'10	'12	For TraX ALU-BOX. See page 84.	KFT.08.725.20000.B
QUICK-LOCK Contour Carrier	'10	'12	For Givi V35 PLX sidecases only. See page 87.	KFT.08.725.15000.B
QUICK-LOCK EVO Tankring	'10	'12	See page 120.	TRT.00.640.14000.B
Crashbar	'10	'12	See page 4.	SBL.08.508.100
Skid Plate	'10	'12	Aluminum, see page 7.	MSS.08.712.10000.B
Mirror Widener	'07	'12	See page 30.	SVL.08.501.101
Handlebar Risers	'10	'12	See page 10.	LEH.08.039.119.S
Auxiliary Light Mount	'10	'12	Mounts under front fairing. See page 64 for Denali LED lighting.	NSW.08.004.10200
Fenda Extenda	'10	'12		PP.053421
R&G Frame Sliders	'10	'12	See page 18.	RG.CP0295BL
R&G Front Axle Sliders	'10	'12	See page 19.	RG.FP0059BK
MRA Windscreen	'10	'12	Several shapes available: See pages 36.	MRA.08.060
Kaoko Throttle Lock	'07	'12	For use WITHOUT Barkbusters Handguards. See page 16.	KAO.KAW200
Kaoko Throttle Lock	'10	'12	For use WITH Barkbusters Handguards. See page 16	KAO.KBB220
Barkbusters Handguards	'07		Full wrap, See page 12.	BB.BHG-VER

MRA VarioTouringScreen



ALU-RACK, black



[See more at TwistedThrottle.com/MyBike](http://TwistedThrottle.com/MyBike)



Concours GTR1000

Concours ZG1000 / GTR1000	from	to	Notes	Part Number
Luggage Rack	'94	'07	For Givi Monokey topcases only	Givi E128
Handlebar Riser	'86	'93	Raises bars 1.25" up	GM.K104
Handlebar Riser	'94	'07	Raises bars 1.25" up	GM.K105
Auxiliary Light mount	'94	'07	Fender Mount Kit for 6mm fender bolts. See page 64 for Denali LED lighting.	TT-D1.020.M6
Oxford Heated Grips	'86	'07	Temperature controlled (4 heat settings), sport and touring grip patterns available.	OXF.26.069
Handlebar Gadget Mount	'86	'07	Universal fits: 7/8" (22mm) up to 1 1/4" (32mm) handlebars	TM.30912
Gadget Mount	'94	'07	10mm mirror mount w/ AMPS hole pattern	TM.31000
Kaoko Throttle Lock	'86	'07	Kit does NOT include a replacement left-side bar end weight.	KAO.KAW200
MRA Touring Screen	'86	'07	Overall length: 21.3 inches (540 mm). See page 36.	MRA.08.030.TA

Handlebar Risers



Luggage Rack



2011 Ninja 1000

[See more at TwistedThrottle.com/MyBike](http://TwistedThrottle.com/MyBike)

Ninja1000 aka Z1000SX	from	to	Notes	Part Number
ALU-RACK, black	'11	'12	Topcase Adapter not included. See page 82.	GPT.08.185.10000.B
QUICK-LOCK EVO Sidecarrier	'10	'12	For TraX ALU-BOX. See page 84.	KFT.08.184.20000.B
QUICK-LOCK Contour Carrier	'10	'12	For Givi V35 PLX sidecases only. See page 87.	KFT.08.184.15000.B
Blaze Sport Saddlebags	'11	'12	1680 Ballistic Nylon. Black. See page 88.	HTA.08.740.10500
QUICK-LOCK EVO Tankring	'11	'12	See page 120.	TRT.00.640.14000.B
QUICK-LOCK GPS Holder	'11	'12	Vibration damped. Black. See page 55.	GPS.08.646.10300.B
Mirror Widener	'11	'12	See page 30.	SVL.00.505.101
R&G Frame Sliders	'11	'12	See page 18.	RG.CP0278
R&G Fender Eliminator	'11	'12	Fender eliminator See page 23.	RG.LP0095BK
R&G Swingarm Spools	'11	'12	See page 19.	RG.SS0030BK
MRA Windscreen	'11	'12	Several shapes available: See page 36.	MRA.08.061

R&G Frame Slider



QUICK-LOCK Contour Carrier & Givi V35 PLX



ALU-RACK, black



Z1000



See more at TwistedThrottle.com/MyBike

Z1000	from	to	Notes	Part Number
ALU-RACK, black	'10	'12	Topcase Adapter not included. See page 82.	GPT.08.648.10000.B
QUICK-LOCK EVO Tankring	'04	'12	See page 120.	TRT.00.640.14000.B
Blaze Sport Saddlebags	'10	'12	QUICK-LOCK, Nylon, Black. See page 88.	HTA.08.740.10200
Crashbars	'10	'12	See page 4.	SBL.08.647.10000.B
Mirror Widener	'03	'09	See page 30.	SVL.00.505.101
Handlebar Risers	'04	'11	See page 10.	GM.K100
Centerstand	'03	'07	See page 6.	HPS.08.217.100
On/Off-road Footpegs	'10	'12	Stainless steel. Silver. See page 34.	FRS.08.011.10000.S
R&G Frame Sliders	'10	'12	No cutting required. See page 18.	RG.CP0264.BL
Kaoko Throttle Lock	'10	'12	See page 16.	KAO.KAW1
Kaoko Throttle Lock	'03	'09	for use with Barbuster Handguards. See page 16.	KAO.KBB300
MRA Windscreen	'10	'12	RacingScreen aka "Double Bubble". See page 38.	MRA.08.059.R

Crashbar



R&G Frame Slider



ALU-RACK, black



2011 ZX10R



See more at TwistedThrottle.com/MyBike

ZX10R	from	to	Notes	Part Number
QUICK-LOCK EVO Tankring	'04	'12	See page 120	TRT.00.640.14000.B
Blaze Sport Saddlebags	'08	'11	QUICK-LOCK, Nylon, Black. See page 88.	HTA.08.740.10000
Mirror Widener	'11	'12	See page 30.	SVL.08.501.11200.B
R&G Frame Sliders	'04	'12	See page 18.	Various
R&G Fender Eliminator	'11	'12	See page 23.	RG.LP0101BK
R&G Bar End Sliders	'04	'11	See page 19.	Various
R&G Adjustable Rearsets	'11	'12	See page 21.	RG.RSET07BK
R&G Engine Case Covers	'06	'12	See page 20.	Various
R&G Axle Sliders	'04	'12	Front and Rear See page 19.	Various
MRA Windscreen	'04	'11	Several shapes available: See page 36.	Various

R&G Bar End Slider



R&G Frame Slider



MRA RacingScreen (2006-2007)





Concours GTR1400

See more at TwistedThrottle.com/MyBike

GTR1400 Concours	from	to	Notes	Part Number
Steel Toprack	'08	'12	Accepts TraX, CooCase, & Givi Topcases. See page 80.	GPT.08.815.20000.B
QUICK-LOCK EVO Tankring	'08	'12	'08-'09 requires fit kit TRT.00.475.140.GTR See page 120.	TRT.00.640.14000.B
GPS Holder	'08	'12	See page 55.	GPS.08.085.100
Handlebar Riser	'08	'12	See page 10.	GM.K405
R&G Crashbar	'08	'12	No cutting required.	RG.AB0002BK
R&G Front Axle Sliders	'08	'12	See page 19.	RG.FP007BK
R&G Bar End Sliders	'08	'12	See page 19.	RG.BE0032BK
R&G Frame Sliders	'08	'12	Some cutting required. See page 18.	RG.CP0213BL
R&G Frame Insert	'08	'12	See page 22	RG.FI0030BK
MFW Vario Footpeg Mount	'08	'12	Rider & passenger options available. See page 32.	MFW.051.05.03
Kaoko Throttle Lock	'08	'12	See page 16.	KAO.KAW100
MRA Windscreen	'08	'12	Several shapes available. See pages 36	MRA.08.050

Handlebar Riser



Steel Toprack



Crashbar



ZX14

See more at TwistedThrottle.com/MyBike

ZZR 1400 / ZX 14	from	to	Notes	Part Number
ALU-RACK, black	'06	'11	Topcase Adapter not included. Requires European Tail Cover. (Part 36040-0059, sold separately). See page 82.	GPT.08.161.100.B
QUICK-LOCK Sidecarrier	'06	'11	Sidecase Adapter Kit not included.	KFT.08.514.100
QUICK-LOCK Contour Carrier	'06	'11	For Givi V35 PLX Sidecases only. See page 87.	KFT.08.514.150
QUICK-LOCK EVO Tankring	'06	'07	See page 120.	TRT.00.640.13500.B
QUICK-LOCK EVO Tankring	'08	'12	See page 120.	TRT.00.640.14000.B
Mirror Widener	'06	'11	Hinge Mirror Widener. See page 30	SVL.08.500.100
Handlebar Riser	'06	'11	See page 10.	GM.K115
Centerstand	'06	'11	See page 6.	HPS.08.516.100
R&G Fender Eliminator	'06	'11	Fender eliminator kit. See page 23.	RG.LP0037
R&G Frame Sliders	'06	'11	No cutting. See page 18.	RG.CP0183BL
MRA Windscreen	'06	'11	Several shapes available: See page 36.	MRA.08.047

Centerstand



QUICK-LOCK Sidecarrier



Contour Sidecarrier for V35 Cases



Barkbusters VPS Handguards



Skid Plate



EXC250



[See more at TwistedThrottle.com/MyBike](http://TwistedThrottle.com/MyBike)

EXC	from	to	Notes	Part Number
Barkbusters Handguards		'12	See page 12.	BB.S4
Skid Plate with Side Protection		'12	3mm-thick aluminum	MSS.04.025.100
Handlebar Risers		'12	30mm rise.	LEH.00.039.110
Tire: MEFO Explorer		'12	DOT dual-sport rear. 120/90-18 or 4.00-18. See page 44.	MEFO.MED19
Tire: MEFO Stone Master		'12	DOT knobby 120/90-18. See page 44.	MEFO.MCE06

690 Enduro & 690 SMC

Steel Toprack



Barkbusters VPS Handguards



Kaoko Throttle Lock



The Twisted 690SMC



[See more at TwistedThrottle.com/MyBike](http://TwistedThrottle.com/MyBike)

690 Enduro & 690 SMC	from	to	Notes	Part Number
Steel Toprack	'08	'12	For 690 Enduro. Topcase Adapter not included. See page 80.	GPT.04.439.20001.B
QUICK-LOCK GPS Holder	'08	'12	Vibration damped. Black. See page 55.	GPS.00.646.10400.B
Barkbusters Handguards	'08	'12	See page 12.	BB.S4
Kaoko Throttle Lock	'08	'12	For use w/ Barkbusters & OEM handguards. See page 16.	KAO.KTMAD
Kaoko Throttle Lock	'08	'12	See page 16.	KAO.KTM100
R&G Bar End Sliders	'08	'12	See page 19.	RG.BE004BK
R&G Front Axle Sliders	'08	'12	See page 19.	RG.FP0085BK
R&G Rear Axle Sliders	'08	'12	See page 19.	RG.SP0002BK



LC4 640 Supermoto



LC4 640 Adventure

[See more at TwistedThrottle.com/MyBike](http://TwistedThrottle.com/MyBike)

LC4 Travel Equipment	from	to	Notes	Part Number
Rear Luggage Rack	'99	'07	Black powdercoated steel. Fits '99- SC, '01- Adventure, & '04 Enduro. Does not fit '05- Enduro.	GPB.04.054.100
QUICK-LOCK EVO Carrier	'99	'07	Not for 690 Enduro/625 SXC. Fits other 640/625 models. Sidecase Adapter not included. See page 84.	KFT.04.157.200
Handlebar Risers for LC4 Adventure	'01	'07	See page 10.	LEH.00.039.106
Mirror Wideners	'99	'07	Universal Mirror Extensions: See page 30.	SVL.00.505.101
Barkbusters Handguards	'99	'07	See page 12.	BB.BHG1
LC4 Lightweight Skid Plates	from	to	Notes	Part Number
Skid Plate for electric-start models	'94	'07	3mm-thick aluminum with side protection. Includes mounting hardware. See page 7.	MSS.04.060.101
LC4 Sidestands	from	to	Notes	Part Number
Enduro (21" front / 18" rear rim)	'94	'99	Compatible w/ original centerstand: Dark gray	STS.04.216.100
Enduro (21" front / 18" rear rim)	'00	'04	Compatible w/ original centerstand: Light silver	STS.04.216.102
Enduro (21" front / 18" rear rim)	'05	'07	Compatible w/ original centerstand: Black	STS.04.216.101
Enduro (21" front / 18" rear rim)	'94	'99	Not compatible w/ original centerstand: Dark gray	STS.04.037.100
Enduro (21" front / 18" rear rim)	'00	'04	Not compatible w/ original centerstand: Light silver	STS.04.037.102
Supermoto (17" front / 17" rear rim)	'94	'99	Not compatible w/ original centerstand: Dark gray	STS.04.037.101
Supermoto (17" front / 17" rear rim)	'00	'04	Not compatible w/ original centerstand: Light silver	STS.04.037.103
Replacement Hollow Nut	'94	'07	For SW-MOTECH LC4 sidestands	STS.04.216.001.4

LC4 Luggage Rack



QUICK-LOCK Sidecarrier



R&G Swingarm Spool



Skid Plate



Sidestand (retracted) w/ original Centerstand



Sidestand with retracted Centerstand



Steel Toprack

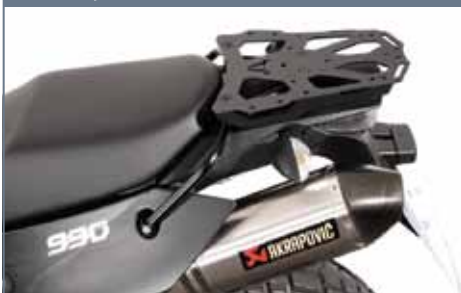

QUICK-LOCK EVO Sidecarrier mounting points



Auxiliary Light Mount



Crashbars for 950 ABS & All 990 Models



Skid Plate for 950 & 990



Radiator Guard for 950



LC8 950 Adventure



[See more at TwistedThrottle.com/MyBike](http://www.TwistedThrottle.com/MyBike)

LC8 Adventure 950 & 990	from	to	Notes	Part Number
Steel Toprack	'02	'12	Accepts TraX, Coocase, & Givi topcases. See page 80.	GPT.04.256.20001.B
QUICK-LOCK EVO Sidecarrier	'02	'12	Sidecase Adapter not included. See page 84.	KFT.04.262.200
QUICK-LOCK GPS Holder	'07	'12	Vibration damped. Black. See page 55.	GPS.00.646.10400.B
Skid Plate, aluminum	'02	'12	See page 7.	MSS.04.250.100
Crashbar	'02	'05	Only for LC8 950 models without ABS. See page 4.	SBL.04.260.100
Crashbar	'02	'12	For LC8 950 models with ABS & all LC8 990 models. See page 4.	SBL.04.488.100
Radiator Guard, silver	'02	'12	Suitable for the 950. Aluminum. See page 9.	KLS.04.389.100
Mirror Wideners	'02	'12	Universal Mirror Extensions: See page 30.	SVL.00.505.101
On/Off-road Footpegs	'02	'12	Stainless steel. Silver. See page 34.	FRS.04.011.10100.S
Auxiliary Light Mount	'02	'12	For Dealii LED lighting see page 64.	NSW.04.004.10000.B
Gadget Mount	'02	'12	7/8" (22mm) up to 1 1/4" (32mm) bar mount	TM.30912
MEFO Tire	'02	'12	DOT knobby & dual spot options available. See page 44.	Various
R&G Engine Case Covers	'02	'12	Left and right side case covers available. See page 20.	Various
R&G Toe Chain Guard	'02	'12	Lower chain guard (a.k.a. shark's fins). See page 22.	RG.TG0001.BK
Barkbusters Handguards	'02	'12	Storm & VPS plastics available	Various
Fenda Extenda	'06	'12	LC8 990Adventure	PP.059350



LC8 950SM

[See more at TwistedThrottle.com/MyBike](http://TwistedThrottle.com/MyBike)



LC8 990SM

On/Off-road Footpegs



Centerstand



QUICK-LOCK EVO Sidecarrier mounting points



Crashbars: 990SM & 990SMR



GPS Holder



Mirror Wideners



950/990 Supermoto, 990 Supermoto R & Super Enduro	from	to	Notes	Part Number
Steel Toprack, black: 950SM	'06	'09	Accepts several different topcases. See page 80.	GPT.04.526.20001.B
Steel Toprack, black: 990SM & SMR	'08	'12	Accepts several different topcases. See page 80.	GPT.04.526.20001.B
QUICK-LOCK EVO Sidecarrier	'07	'12	Sidecase Adapter not included; Additional fit kit required for use on Super Enduro. See page 84.	KFT.04.621.20001.B
Sidecarrier Fit Kit	'07	'09	Required to mount Sidecarrier on Super Enduro.	KFT.04.262.005
QUICK-LOCK GPS Holder	'07	'12	Vibration damped. Black. See page 55.	GPS.00.646.10400.B
Crashbars: 990SM & 990SMR	'07	'12	See page 4.	SBL.04.650.10000.B
Centerstand	'07	'12	See page 6.	HPS.04.684.10000.B
Handlebar Risers	'07	'12	See page 10.	LEH.00.039.106
Mirror Wideners	'07	'12	Universal Mirror Extensions: See page 30.	SVL.00.505.101
Auxiliary Light Mount	'07	'12	See page 64 for Denali LED lighting.	NSW.04.004.10000.B
On/Off-road Footpegs	'07	'12	Stainless steel. Silver. See page 34.	FRS.04.011.10100.S
R&G Fender Eliminator	'07	'12	See page 23.	RG.LP0057BK
R&G Engine Case Covers	'07	'12	Left and right side case covers available. See page 20.	Various
R&G Front Axle Sliders	'07	'12	See page 19.	RG.FP0033BK
MEFO Tire	'07	'12	DOT knobby & dual spot options available. See page 44.	Various
Barkbusters Handguards	'07	'12	Storm & VPS plastics available. See page 12.	Various
Kaoko Throttle Lock	'07	'12	See page 16.	KAO.KTM100
MRA Highwayshield	'07	'12	Handlebar mount kit required. See page 40.	MRA.HI

Chain Guard



QUICK-LOCK EVO Sidecarrier mounting points



Crashbars



Skid Plate, black



Centerstand



GPS Holder



Mirror Wideners

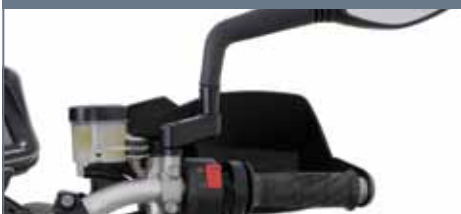

On/Off-road Footpegs



LC8 990SMT



[See more at TwistedThrottle.com/MyBike](http://TwistedThrottle.com/MyBike)

LC8 990 Supermoto T	from	to	Notes	Part Number
Steel Toprack	'10	'12	Topcase Adapter not included. See page 80.	GPT.04.616.20001.B
QUICK-LOCK EVO Sidecarrier	'10	'12	Sidecase Adapter not included. See page 84.	KFT.04.621.20001.B
Skid Plate	'10	'12	Powdercoated black. See page 7.	MSS.04.651.10000.B
Crashbar	'10	'12	See page 4.	SBL.04.650.10000.B
Chain Guard	'10	'12	Aluminum.	KTS.04.652.10000.B
Centerstand	'10	'12	See page 6.	HPS.04.696.10000.B
Handlebar Risers	'10	'12	See page 10.	LEH.00.039.106
Mirror Wideners	'10	'12	Universal Mirror Extensions: See page 30.	SVL.00.505.101
Auxiliary Headlight Mount	'10	'12	See page 64 for Denali LED lighting.	NSW.04.004.10100
On/Off-road Footpegs	'10	'12	Stainless steel. Silver. See page 34.	FRS.04.011.10100.S
Auxiliary Light Mount	'10	'12	All mounting hardware & instructions included.	NSW.04.004.10000.B
Kaoko Throttle Lock	'10	'12	See page 16.	KAO.KTM100

AN400 Burgman



See more at TwistedThrottle.com/MyBike

AN400 Burgman	from	to	Notes	Part Number
Scooter Rack (for "Type S" model)	'05	'07	For Coccase, Givi Monokey & Monolock topcases	GPT.05.8004.30000.B
Handlebar Risers	'01	'12	Rise 1", pull back 1". See page 10.	LEH.00.039.152
GPS Holder	'00	'12	For all Garmin Zumo or TomTom Rider GPS.	GPS.05.053.100
Givi sidecase carrier	'07	'12	Requires FHG.7813SV. Cannot be used with FHG.7814SH	FHG.7817KH
Luggage Rack	'07	'12	For Givi Monokey or Monolock topcases only	Givi E531
Backrest	'07	'12	Cannot be used without also installing Givi E531 Luggage Rack	Givi TB531
Windscreen	'00	'06	Also fits AN400 Type S. 31"h x 28"w, Clear	Givi D258ST
Windscreen	'07	'12	33"h x 27"w, Clear	Givi D266ST
Tankbag	'01	'12	12.6"x11.8"x9.8" Expandable Bag, 18-liter volume	Givi T455
Saddlebags	'01	'12	28 to 35-liter capacity 500mm long x 280mm tall x 200-250mm wide (expandable).	Givi T449

Sidecase Carrier



Windscreen



Scooter Rack



GPS Holder



DRZ400SM



See more at TwistedThrottle.com/MyBike

DRZ400S & DRZ400SM	from	to	Notes	Part Number
Steel Toprack	'02	'12	Accepts several different topcases. See page 80.	GPT.05.827.20001.B
QUICK-LOCK EVO Sidecarrier	'02	'11	For use with or without original top carrier Sidecase Adapter not included. See page 84.	KFT.05.801.20000.B
R&G Front Axle Sliders	'02	'11	See page 19.	RG.FP0028BK
R&G Exhaust Protectors	'02	'11	See page 21.	Various
Barkbusters Handguards	'02	'12	Several options available. See page 12.	Various

R&G Supermoto Exhaust Protector



R&G Front Axle Slider



QUICK-LOCK EVO Sidecarrier



ALU-RACK, black



Crashbars, black : GS500E



2009 GS500F

See more at TwistedThrottle.com/MyBike

GS500E & GS500F	from	to	Notes	Part Number
ALU-RACK, black	'89	'11	Topcase Adapter not included. See page 82.	GPT.05.285.100.B
QUICK-LOCK EVO Tankring	'89	'11	E & F models both. See page 120.	TRT.00.640.11500.B
Crashbars, black: GS500E	'05	'02	For GS500E only. See page 4.	SBL.05.339.100
Handlebar Risers & Barbacks	'89	'11	See page 10 (LEH.00.039150 or LEH.00.039152)	Various
Mirror Widener: GS500E	'89	'02	For GS500E only: See page 30	SVL.00.505.101
Mirror Widener: GS500F	'89	'11	For GS500F only: See page 30	SVL.00.500.100
MRA Windscreen	'89	'11	Several shapes available: See page 36.	

Mirror Wideners



R&G Adjustable Rearset



MRA Double-Bubble RacingScreen



Blaze Sport Saddlebags



2005 GSX-R600



See more at TwistedThrottle.com/MyBike

Exhaust Protector & Exhaust Hanger



Engine Covers and Frame Plugs



GSXR600	from	to	Notes	Part Number
Blaze Sport Saddlebags	'08	'12	QUICK-LOCK, Nylon, Black. See page 88.	HTA.05.740.10200
QUICK-LOCK EVO Tankring	'97	'12	See page 120.	TRT.00.640.12500.B
Mirror Wideners	'08	'12	See page 30.	SVL.05.501.11000.B
R&G Adjustable Rearsets	'06	'12	See page 21.	Various
R&G Frame Sliders	'00	'12	Cut and "no-cut" options available. See page 18.	Various
R&G Bar End Sliders	'00	'12	Pair. See page 19.	RG.BE0002BK
R&G Exhaust Hanger	'11	'12	See page 21.	RG.EH0048BK
R&G Exhaust Protector	'11	'12	Several shapes for OEM & aftermarket exhausts available. See page 21.	Various
MRA Windscreen	'00	'12	Several shapes available: See page 36.	Various



AN650 Burgman Executive

[See more at TwistedThrottle.com/MyBike](http://TwistedThrottle.com/MyBike)

AN650/AN650 Executive Burgman	from	to	Notes	Part Number
Coocase Rack	'02	'12	See page 111.	GPT.05.8005.30000.B
Coocase S50 topcase	'02	'12	Basic (.B) & Luxury (.LLW) editions available. See page 107-108.	CC.S50.
Givi sidecase carrier	'02	'12	FHG.7828ZHV sidecarrier fitting kit or Fehling front crashbars required	FHG.7847KH
GPS Holder	'02	'12	For all Garmin Zumo or TomTom Rider GPS.	GPS.05.090.100
Handlebar Risers			Up 1" & back 1". See page 10.	LEH.00.039.152
Windscreen (for standard model)	'02	'12	29"h x 31"w. Clear tint.	Givi D257ST
Windscreen (for Executive model)	'02	'12	31"h x 28"w. Clear tint.	Givi D263ST
Kaoko Throttle Lock	'02	'12	Available in black or chrome. See page 16.	KAO.SUZ400

GPS Holder



Coocase Rack



Sidecase Carrier



GSF650S Bandit

[See more at TwistedThrottle.com/MyBike](http://TwistedThrottle.com/MyBike)

GSF650 & GSF650S Bandit	from	to	Notes	Part Number
ALU-RACK, black	'05	'12	Topcase Adapter not included. See page 82.	GPT.05.299.100
QUICK-LOCK EVO Sidecarrier	'06	'12	For ABS models only: Sidecase Adapter not included. See page 84.	KFT.05.403.200
QUICK-LOCK Contour Sidecarrier	'06	'12	Only for ABS models with Givi V35 sidecases. See page 87.	KFT.05.403.150
QUICK-LOCK EVO Tankring	'97	'12	See page 120.	TRT.00.640.12500.B
Blaze Sport Saddlebags	09	'12	QUICK-LOCK, Nylon, Black. See page 88.	HTA.05.740.10300
Crashbars, black	'07	'12	See page 4.	SBL.05.384.100
Mirror Widener	'05	'12	(SVL.05.500.100 or SVL.00.505.101) See page 30.	Various
Handlebar Risers & Barbacks	'05	'12	(LEH.00.039.150 or LEH.00.039.152) See page 10.	Various
R&G Frame Sliders	'05	'12	No Mods. Lower Engine Mount. See page 18.	RG.CP0206
MRA Windscreen	'05	'12	Several shapes available: See page 36.	Various

ALU-RACK, black



QUICK-LOCK Contour Sidecarrier



R&G Frame Slider



Crashbars



ALU-RACK, black



Skid Plate, silver



Denali LED Lighting Kit



DR650SE



[See more at TwistedThrottle.com/MyBike](http://TwistedThrottle.com/MyBike)

DR650SE	from	to	Notes	Part Number
ALU-RACK, black	'96	'12	Topcase Adapter not included. See page 82.	GPT.05.153.100.B
QUICK-LOCK Sidecarrier	'96	'12	Sidecase Adapter not included. See page 84.	KFT.05.149.100
Skid Plate, silver	'96	'12	Aluminum. See page 7.	MSS.05.123.100
Centerstand	'96	'12	See page 6.	HPS.05.167.100
Barkbusters Handguards	'96	'12	Ego, Storm & VPS options available. See page 12.	Various
Denali LED Lighting Kit	'96	'12	See page 64.	TT-D2D
Mirror Wideners	'96	'12	See page 30.	SVL.00.505.101
Kaoko Throttle Lock	'96	'12	See page 16.	KAO.DR650SE
Handelbar Risers	'96	'12	See page 10 (LEH.00.039.152 or LEH.00.039150)	Various

ALU-RACK, black



QUICK-LOCK EVO Sidecarrier



Crashbars, black



Gladius SFV650



[See more at TwistedThrottle.com/MyBike](http://TwistedThrottle.com/MyBike)

Gladius SFV650	from	to	Notes	Part Number
ALU-RACK, black	'09	'12	Topcase Adapter not included. See page 82.	GPT.05.631.10000.B
QUICK-LOCK EVO Sidecarrier	'09	'12	Fits multiple racks: Sidecase Adapter not included. See page 84.	KFT.05.630.20000.B
QUICK-LOCK EVO Tankring	'09	'12	See page 120.	TRT.00.640.12500.B
Crashbars, black	'09	'12	See page 4.	SBL.05.632.10000.B
Radiator Guard	'09	'10	Black seamless aluminum frame. See page 20.	RG.RAD0074
Mirror Widener	'09	'12	Universal mirror widener. See page 30.	SVL.00.505.101
Handlebar Risers & Barbacks	'09	'12	See page 10. (LEH.00.039.150 or LEH.00.039.152)	Various
R&G Frame Sliders	'09	'12	"Aero" style. Front engine mount. See page 18.	RG.CP0255BL
Barkbusters Handguards	'09	'12	Single-sided aluminum backbone w/ Storm plastics. See page 12.	BB.S1
MRA Windscreen	'09	'12	Several shapes available. See page 36.	Various

Steel Toprack



QUICK-LOCK EVO Sidecarrier mounting points



Auxiliary Headlight Mount (Denali D2 not included)



Crashbars, black



Centerstand, black



Skid Plate



Radiator Guard, silver



2004 - 2011
DL650 V-Strom



[See more at TwistedThrottle.com/MyBike](http://TwistedThrottle.com/MyBike)

DL650 V-Strom	from	to	Notes	Part Number
Steel Toprack	'04	'11	Accepts TraX, Coocase, & Givi topcases. See page 80.	GPT.05.293.20001.B
QUICK-LOCK EVO Sidecarrier	'04	'11	Fits multiple racks: Sidecase Adapter not included. See page 84.	KFT.05.294.200
QUICK-LOCK EVO Tankring	'04	'11	See page 120.	TRT.00.640.11500.B
QUICK-LOCK GPS Holder	'04	'11	Vibration damped, black. See page 55.	GPS.00.646.10500.B
Givi PLX sidecarrier	'04	'11	For Givi V35 PLX sidecases only	Givi PLX532
Crashbars, black	'04	'11	See page 4.	SBL.05.674.10000.B
Radiator Guard silver	'04	'11	Aluminum. See page 8.	KLS.05.401.100
Chain Guard	'04	'11	Aluminum	KTS.05.164.100
Skid Plate	'04	'11	Aluminum. The SW-MOTECH or Suzuki OEM crashbar is required for mounting this skid plate on the bike. See page 7.	MSS.05.296.10001.B
Master Cylinder Guard: rear	'04	'11	See page 8.	BPS.05.175.10000.S
Handlebar Risers & Barbacks	'04	'11	See page 10 (LEH.00.039.150 or LEH.00.039.152).	Various
Mirror Widener	'04	'11	Universal mirror widener. See page 30.	SVL.00.505.101
Centerstand	'04	'11	See page 6.	HPS.05.257.100
Auxiliary Headlight Mount	'04	'11	See page 64 for Denali LED lighting.	LAH.05.456.100
On/Off-road Footpegs	'04	'11	Stainless Steel. Silver. See page 34.	FRS.05.011.10000.S
Adjustable Windshield Bracket	'04	'11		MAD.AWM-05
Stebel Airhorn Mount	'04	'11	Airhorn sold separately See page 71.	HMT.05.821.10000
R&G Frame Sliders	'06	'11	No cutting required: See page 18.	RG.CP0144.BL
Barkbusters VPS Handguards	'04	'11	See page 12.	BB.BHG31
MRA Windscreen	'04	'11	Several shapes available: See page 36	MRA.05.037



2012 DL650 V-Strom



See more at TwistedThrottle.com/MyBike

DL650 V-Strom	from	to	Notes	Part Number
Steel Toprack	'12		Accepts several different topcases. See page 80.	GPT.05.758.20001.B
QUICK-LOCK EVO Sidecarrier	'12		Fits multiple racks: Sidecase Adapter not included. See page 84.	KFT.05.765.20000.B
QUICK-LOCK EVO Tankring	'12		See page 120.	TRT.00.640.12500.B
QUICK-LOCK GPS Holder	'12		Vibration damped, black. See page 55.	GPS.05.646.10200.B
Crashbars, black	'12		See page 4.	SBL.05.757.10000.B
Skid Plate	'12		Aluminum. See page 7.	MSS.05.759.10000.B
Master Cylinder Guard: rear	'12		See page 8.	BPS.05.175.10000.S
Mirror Widener	'12		See page 30.	SVL.00.505.10500.B
Handlebar Risers	'12		Available in 20, 25, 30 & 50mm rise. See page 10.	LEH.00.039150
Auxiliary Light Mount	'12		See page 64 for Denali LED lighting.	NSW.05.004.10100.B
Centerstand	'12		See page 6.	HPS.05.764.10000.B
On/Off-road Footpegs	'12		Stainless steel. Silver. See page 34.	FRS.05.011.10000.S
Givi PLX Sidecarrier	'12		For Givi V35 PLX sidecases only.	Givi PLX3101
R&G Frame Sliders	'12		See page 18.	RG.CP0297BL
R&G Bar End Sliders	'12		See page 19.	RG.BE0017BK
R&G Radiator Guard	'12		See page 20.	RG.RAD0112BK
MRA Windscreen	'12		Several shapes available: See page 36.	MRA.05.059
Barkbusters Handguards	'12		See page 12.	BB.BHG44

Steel Toprack, black



QUICK-LOCK EVO Sidecarrier



Auxiliary Light Mount (light not included)



Crashbars, black



Centerstand



Skid Plate



Barkbusters Handguard





GSX650F

See more at TwistedThrottle.com/MyBike

GSX650F	from	to	Part Number
ALU-RACK, black	'08	'11	Topcase Adapter not included. See page 82. GPT.05.299.100
QUICK-LOCK EVO Sidecarrier	'09	'11	For TraX ALU-BOX: Sidecase Adapter not included. See page 84. KFT.05.403.200
QUICK-LOCK Contour Carrier	'08	'11	For Givi V35 PLX sidecases only. See page 87. KFT.05.403.150
QUICK-LOCK EVO Tankring	'09	'12	See page 120. TRT.00.640.12500.B
R&G Frame Sliders	'08	'11	No-cut installation. Pair . Black. See page 18. RG.CP0231
Kaoko Throttle Lock	'08	'12	See page 16. KAO.SUZ200
MRA Windscreen	'08	'11	Several shapes available: See page 36. MRA.05.056

ALU-RACK, black



Quick-Lock EVO Sidecarrier



QUICK-LOCK Contour Carrier (Givi V35 bags not included)



SV650S

See more at TwistedThrottle.com/MyBike

SV650, SV650S, & SV650F	from	to	Notes	Part Number
ALU-RACK, black	'03	'07	Topcase Adapter not included. See page 82.	GPT.05.232.100.B
QUICK-LOCK Sidecarrier	'03	'03	For S model 2003 ONLY. Sidecase Adapter not included.	KFT.05.227.100
QUICK-LOCK Sidecarrier	'04	'08	Sidecase Adapter not included.	KFT.05.226.100
QUICK-LOCK EVO Tankring	'03	'07	See page 120.	TRT.00.640.12500.B
Mirror Widener	'03	'07	See page 30.	Various
Centerstand	'03	'07	See page 6.	HPS.05.219.100
Handlebar Risers & Barbacks	'03	'07	For naked model only: See page 10.	Various
Handlebar Socket Mount	'03	'12	12v cigarette lighter socket - flush mount. See page 61.	CPA.00.006.160
Handlebar Socket Mount	'03	'12	12v BMW/euro socket - flush mount. See page 61.	CPA.00.006.150
R&G Frame Sliders	'03	'12	No cutting required. See page 18.	RG.CP0123BL
R&G Fender Eliminator	'03	'12	See page 23.	RG.LP0010BK
MRA Windscreen	'03	'07	Several shapes available: See page 36.	Various

ALU-RACK, black



QUICK-LOCK Sidecarrier mounting points



Mirror Widener



Centerstand



MRA VarioTouringscreen



QUICK-LOCK EVO Sidecarrier mounting points

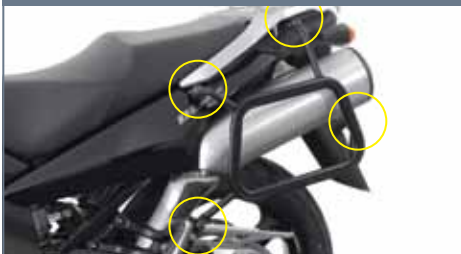

Mirror Widener



Crashbars, black



Skid Plate, silver



Centerstand



Barkbusters VPS Handguard



DL1000 V-Strom



[See more at TwistedThrottle.com/MyBike](http://TwistedThrottle.com/MyBike)

DL1000 V-Strom	from	to	Notes	Part Number
Steel Toprack	'02	'11	Accepts TraX, CooCase, & Givi topcases. See page 80.	GPT.05.293.20000.B
QUICK-LOCK EVO Tankring	'04	'11	See page 120.	TRT.00.640.11500.B
QUICK-LOCK EVO Sidecarrier	'02	'11	Fits multiple racks: Sidecase Adapter not included. See page 84.	KFT.05.158.200
Givi PLX Sidecarrier	'02	'11	For Givi V35 PLX sidecases only	Givi PLX528
Crashbars, black	'02	'11	See page 4.	SBL.05.170.100
Chain Guard	'02	'11	Aluminum	KTS.05.264.100
Skid Plate, silver or black	'02	'11	Aluminum. The SW-MOTECH or Suzuki OEM crashbar is required for mounting this skid plate on the bike. See page 7.	MSS.05.265.100
Mirror Widener	'04	'11	Universal mirror widener. See page 30.	SVL.00.505.101
Handlebar Risers & Barbacks	'02	'11	See page 10 (LEH.00.039.150 or LEH.00.039.152).	Various
QUICK-LOCK GPS Holder	'04	'11	Vibration damped. Black. See page 55.	GPS.00.646.10500.B
Centerstand	'02	'11	See page 6.	HPS.05.159.100
Auxiliary Headlight Mount	'02	'11	See page 64 for Denali LED lighting.	LAH.05.456.100
Stebel Airhorn Mount	'04	'11	See page 71 for airhorn (sold separately).	HMT.05.821.10000
MadStad Bracket	'04	'11		MAD.AWM-05
R&G Frame Sliders	'03	'09	See page 18.	Various
Barkbusters Handguards	'02	'11	See page 12.	BB.BHG44
Fenda Extenda	'04	'11		PP.05025
Kaoko Throttle Lock	'02	'11	Options for use with and without Barkbusters or OEM handguards. See page 16.	Various
MRA Windscreen	'02	'11	Several shapes available. (Vario Touringscreen pictured above) See page 36.	MRA.05.03



GSXR1000

[See more at TwistedThrottle.com/MyBike](http://TwistedThrottle.com/MyBike)

GSX-R750 & GSX-R1000	from	to	Notes	Part Number
QUICK-LOCK EVO Tankring	'01	'11	See page 120.	TRT.00.640.12500.B
Blaze Sport Saddlebags	'08	'11	GSXR 750 QUICK-LOCK, Nylon, Black. See page 88.	HTA.05.740.10000
Blaze Sport Saddlebags	'09	'11	GSXR 1000 QUICK-LOCK, Nylon, Black. See page 88.	HTA.05.740.10000
Mirror Widener	'85	'11	See page 30.	SVL.05.501.10800.B
R&G Front Axle Sliders	'05	'11	No cutting required: See page 19.	RG.FP0025BK
R&G Bar End Sliders	'00	'11	See page 19.	RG.BE0002BK
R&G Fender Eliminator	'09	'11	See page 23.	RG.LP0077BK
Kaoko Throttle Lock	'05	'11	See page 16.	KAO.SUZ100
MRA Windscreen	'85	'11	Several shapes available: See page 36.	MRA.05.05

MRA Double-Bubble RacingScreen



R&G Bar End Slider



R&G Front Axle Slider



SV1000S

[See more at TwistedThrottle.com/MyBike](http://TwistedThrottle.com/MyBike)

SV1000 & SV1000S	from	to	Notes	Part Number
ALU-RACK, black	'03	'11	Topcase Adapter not included See page 82.	GPT.05.232.100.B
QUICK-LOCK Sidecarrier	'03	'03	For 2003 SV1000S only. Sidecase Adapter not included.	KFT.05.227.100
QUICK-LOCK Sidecarrier	'04	'11	Also fits 2003 SV1000N. Sidecase Adapter not included.	KFT.05.226.100
QUICK-LOCK EVO Tankring	'03	'11	See page 120.	TRT.00.640.12500.B
Mirror Widener	'03	'11	(SVL.05.500.100 or SVL.00.505.101) See page 30.	Various
Handlebar Risers & Barbacks	'03	'11	See page 10 (LEH.00.039.150 or LEH.00.039.152) for naked model only.	Various
R&G Frame Sliders	'06	'11	See page 18.	RG.CP0123BL
Barbuster Handguards	'03	'11	See page 12.	BB.S1
Kaoko Throttle Lock	'03	'11	See page 16.	KAO.SUZ300
MRA Windscreen	'03	'11	Several shapes available: See page 36.	Various

ALU-RACK, black



QUICK-LOCK Sidecarrier



R&G Frame Slider





GSF1250S Bandit

[See more at TwistedThrottle.com/MyBike](http://TwistedThrottle.com/MyBike)

GSF1250 & GSF1250S Bandit	from	to	Notes	Part Number
ALU-RACK, black	'07	'12	Topcase Adapter not included. See page 82.	GGPT.05.299.100.B
QUICK-LOCK EVO Sidecarrier	'07	'12	Fits multiple racks: Sidecase Adapter not included. See page 84.	KFT.05.403.200
QUICK-LOCK Contour Carrier	'07	'12	For use with Givi V35 sidecases only. See page 87.	KFT.05.403.150
QUICK-LOCK EVO Tankring	'07	'12	See page 120.	TRT.00.640.12500.B
Blaze Sport Saddlebags	'07	'12	QUICK-LOCK, Nylon, Black. See page 88.	HTA.05.740.10100
Crashbars, black	'07	'12	See page 4.	SBL.05.383.100
Chain Guard	'07	'12		KTS.05.522.100
Mirror Widener: GSF1250S	'07	'12	Fits GSF1250S half-faired model: See page 30.	SVL.05.500.100
Mirror Widener: GSF1250N	'07	'12	Fits GSF1250 naked model: See page 30.	SVL.00.505.101
Handlebar Risers & Barbacks	'07	'12	See page 10 (LEH.00.039.150 or LEH.00.039.152).	Various
Kaoko Throttle Lock	'07	'12	See page 16.	KAO.SUZ100
MFW Vario Footpeg Mount	'07	'12	Rider & passenger options available. See page 32.	Various
MRA Windscreen	'07	'12	Several shapes available: See page 36.	Various

ALU-RACK, black



QUICK-LOCK EVO Sidecarrier



Crashbars, black



Chain Guard, silver



ALU-RACK, black



QUICK-LOCK EVO Sidecarrier



R&G Front Axle Slider



GSX1250FA

[See more at TwistedThrottle.com/MyBike](http://TwistedThrottle.com/MyBike)

GSX1250FA	from	to	Notes	Part Number
ALU-RACK, black	'10	'11	Topcase Adapter not included. See page 82.	GPT.05.299.100.B
QUICK-LOCK EVO Sidecarrier	'10	'11	Sidecase Adapter not included. See page 84.	KFT.05.403.200
QUICK-LOCK Contour Carrier	'10	'11	Sidecase Adapter not included. See page 87.	KFT.05.403.150
QUICK-LOCK EVO Tankring	'10	'11	See page 120.	TRT.00.640.12500.B
R&G Front Axle Sliders	'10	'11	See page 19.	RG.FP0065BK
R&G Frame Sliders	'10	'11	See page 18.	Various
R&G Engine Case Covers	'10	'11	See page 20.	Various
MRA Windscreen	'10	'11	Several shapes available: See page 36.	MRA.05.056



GSX1300R Hayabusa

See more at TwistedThrottle.com/MyBike

GSX1300R Hayabusa	from	to	Notes	Part Number
ALU-RACK, black	'99	'07	Topcase Adapter not included. See page 82.	GPT.05.209.100.B
QUICK-LOCK EVO Sidecarrier	'99	'07	Sidecase Adapter not included See page 84.	KFT.05.203.20000.B
QUICK-LOCK EVO Tankring	'99	'07	See page 120.	TRT.00.640.11500.B
Handlebar Risers	'99	'07	Moves bars up 1.25" See page 10.	GM.S123
Mirror Wideners	'99	'07	See page 30.	SVL.05.501.101
R&G Front Axle Sliders	'99	'07	See page 19.	RG.FP0009BK
R&G Frame Sliders	'99	'07	See page 18.	RG.CP0063
MFW Vario Footpeg Mount	'99	'07	Rider & passenger options available. See page 32.	Various
MRA Windscreen	'99	'07	Several shapes available: See page 36.	MRA.05.050
Kaoko Throttle Lock	'99	'07	See page 16.	KAO.SUZ200

ALU-RACK, black



QUICK-LOCK EVO Sidecarrier mounting points



R&G Front Axle Slider



GSX1340R Hayabusa

See more at TwistedThrottle.com/MyBike

GSX1340R Hayabusa	from	to	Notes	Part Number
ALU-RACK, black	'08	'12	Topcase Adapter not included. See page 82.	GPT.05.576.100.B
QUICK-LOCK EVO Sidecarrier	'08	'12	Sidecase Adapter not included. See page 84.	KFT.05.575.200
QUICK-LOCK Contour Carrier	'08	'12	For use with Givi V35 PLX sidecases. See page 87.	KFT.05.575.150
QUICK-LOCK EVO Tankring	'08	'12	See page 120.	TRT.00.640.11500.B
Blaze Sport Saddlebags	'08	'12	QUICK-LOCK, Nylon, Black. See page 88.	HTA.05.740.10500
Handlebar Risers	'08	'12	Moves bars up 0.75" - 1.25" See page 10.	GM.S222 or GM.S223
R&G Frame Sliders	'08	'12	See page 18.	RG.CP0222.BL
Kaoko Throttle Lock	'08	'12	See page 16.	KAO.SUZ-08
MFW Vario Footpeg Mount	'08	'12	Rider & passenger options available. See page 32.	Various
MRA Windscreen	'08	'12	Several windscreen shapes available: See page 36.	MRA.05.055

ALU-RACK, black



QUICK-LOCK EVO Sidecarrier mounting points



R&G Frame Slider



R&G Bar End Slider



R&G Engine Case Cover



R&G Front Axle Slider



Daytona 675

[See more at TwistedThrottle.com/MyBike](http://TwistedThrottle.com/MyBike)

Daytona 675 Triple	from	to	Notes	Part Number
QUICK-LOCK EVO Tankring	'06	'12	See page 120.	TRT.00.640.16000.B
Mirror Wideners	'06	'12	Profile extension See page 30.	SVL.11.501.10000.B
R&G Frame Sliders	'06	'12	See page 18.	RG.CP0173.BL
R&G Front Axle Sliders	'06	'12	See page 19.	RG.FP0047BK
R&G Engine Case Cover	'06	'12	Left & right covers available See page 20.	RG.ECC00
R&G Fender Eliminator	'06	'12	See page 23.	RG.LP0023BK
R&G Bar End Sliders	'06	'12	See page 19.	RG.BE0026BK
Adjustable Footpeg Mounts	'06	'12	Rider & passenger options available. See page 32.	MFW.051.07.0
Gadget Mount	'06	'12	Mounts to steering stem nut.	TM.40001
MRA Windscreen	'06	'12	Several shapes available: See page 36.	Various

Street Triple 675 & Street Triple R

R&G Frame Slider



ALU-RACK, black



Crashbars, black



Centerstand



2012 Street Triple 675

[See more at TwistedThrottle.com/MyBike](http://TwistedThrottle.com/MyBike)

Street Triple 675 & Street Triple R	from	to	Notes	Part Number
ALU-RACK, black	'08	'11	Topcase Adapter not included. See page 82.	GPT.11.574.10000.B
QUICK-LOCK EVO Tankring	'08	'12	See page 120.	TRT.00.640.16000.B
Blaze Sport Saddlebags	'11	'12	QUICK-LOCK, Nylon, Black. See page 88.	HTA.11.740.10200
Crashbars, black	'08	'11	See page 4.	SBL.11.431.10000.B
Centerstand	'08	'11	See page 6.	HPS.11.416.10000.B
Handlebar Risers & Barbacks	'08	'11	See page 10 (LEH.00.039150 or LEH.00.039152).	Various
R&G Frame Sliders	'07	'12	See page 18.	RG.CP0217.BL
R&G Front Axle Sliders	'06	'12	See page 19.	RG.FP0047BK
R&G Swingarm Spools	'06	'12	See page 19.	RG.CR0001.BK
R&G Fender Eliminator	'06	'12	See page 23.	RG.LP0056BK
R&G Bar End Sliders	'06	'12	See page 19.	RG.BE0010BK



Bonneville T100

[See more at TwistedThrottle.com/MyBike](http://www.TwistedThrottle.com/MyBike)

Bonneville (2001 & Later) & Bonneville T100	from	to	Notes	Part Number
Handlebar Risers	'01	'12	Raises the bars up 1 1/4" (32mm) and back 3/4" (19mm). See page 10.	GM.T114
R&G Frame Sliders	'06	'09	See page 18.	RG.CP0259BL
R&G Front Axle Sliders	'06	'09	See page 19.	RG.FP0091BK
Kaoko Throttle Lock	'01	'12	See page 16.	KAO.BONI
MRA Windscreen	'01	'12	Several shapes available: See page 36.	Various
Bonneville America	from	to	Notes	Part Number
Handlebar Risers & Barbacks	'02	'12	See page 10 (LEH.00.039150 or LEH.00.039152).	Various
GPS Accessory Mount	'02	'12	Attaches to handlebar control clamps (clutch or brake side).	TM.31001
Kaoko Throttle Lock	'02	'12	See page 16.	KAO.BONI
MRA Windscreen	'02	'12	Several shapes available: See page 36.	Various

R&G Front Axle Slider



MRA windscreens for naked bikes



Kaoko Throttle Lock



Thruxton 900

[See more at TwistedThrottle.com/MyBike](http://www.TwistedThrottle.com/MyBike)

Thruxton 900	from	to	Notes	Part Number
GPS Accessory Mount	'04	'11	Attaches to handlebar control clamps (clutch or brake side).	TM.31001
R&G Frame Sliders	'04	'11	See page 18.	RG.CP0259BL
Kaoko Throttle Lock	'04	'11	See page 16.	KAO.THRUX
MRA Windscreen	'04	'11	Several shapes available: See page 36.	Various
Scrambler	from	to	Notes	Part Number
Handlebar Risers	'06	'11	Rise height by 20mm, 25mm, 30mm or 50mm. See page 10.	LEH.00.039150
R&G Front Axle Sliders	'06	'12	See page 19.	RG.FP0091BK
Kaoko Throttle Lock	'06	'11	See page 16.	KAO.THRUX
MRA Windscreen	'06	'11	Several shapes available: See page 36.	Various

R&G Frame Slider



Kaoko Throttle Lock



MRA windscreens for naked bikes



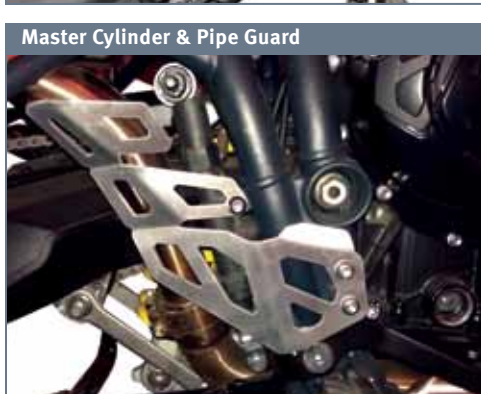
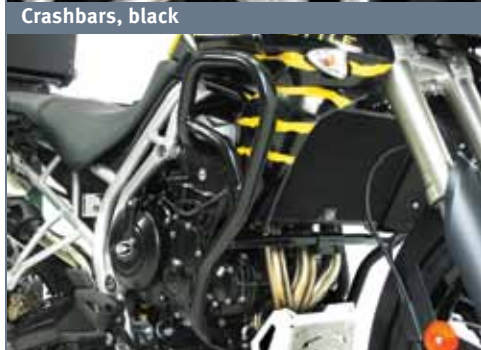
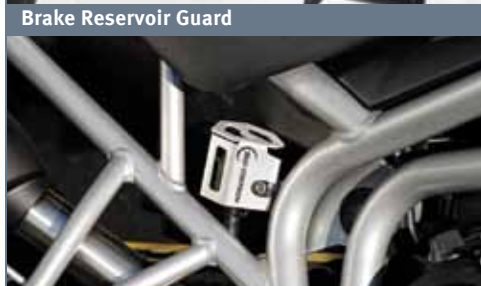

View our Tiger 800XC project bike video.



2011 Tiger 800XC

See more at TwistedThrottle.com/MyBike

Tiger 800 and 800XC,	from	to	Notes	Part Number
Steel Toprack, black	'11	'12	Topcase Adapter not included. See page 80.	GPT.11.747.20001.B
QUICK-LOCK EVO Sidecarrier	'11	'12	Sidecase Adapter not included. See page 84.	KFT.11.748.20000.B
QUICK-LOCK EVO Tankring	'11	'12	See page 120.	TRT.00.640.16000.B
Crashbars	'11	'12	See page 4.	SBL.11.749.10000.B
Skid Plate	'11	'12	See page 7.	MSS.11.752.10000.B
Headlight Protector	'11	'12	Black. Model specific for Tiger 800 & Tiger 800XC.	LPS.11.124.1000.B
Brake Reservoir Guard	'11	'12	4mm aluminum, silver. Specific for Tiger 800XC. See page 8.	SCT.11.174.10000.S
Master Cylinder & Pipe Guard	'11	'12	4mm aluminum, silver. Right hand side. See page 8.	SCT.11.174.10100.S
Heel Guard	'11	'12	4mm aluminum, silver. Left-hand side. See page 8.	SCT.11.174.10200.S
Auxiliary Light Mount	'11	'12	See page 64 for Denali LED lighting.	NSW.11.004.10100.B
On/Off-road Footpegs	'11	'12	Stainless steel, silver. See page 34.	FRS.11.011.10100.S
Centerstand	'11	'12	Canadian models only. See page 6.	HPS.11.75
Handlebar Risers	'11	'12	20mm of rise without changing the control cables, wiring, or hoses. See page 10.	LEH.11.039.10000.S
Barkbusters VPS Handguards	'11	'12	See page 12.	BB.BHG43
Kaoko Throttle Lock	'11	'12	Fits the Tiger 800 & 800XC. See page 16.	KAO.TIGXC
MRA Windscreen	'11	'12	Several shapes available: See page 36.	MRA.11.013





Sprint ST 955

[See more at TwistedThrottle.com/MyBike](http://www.TwistedThrottle.com/MyBike)

Sprint RS & Sprint ST 955	from	to	Notes	Part Number
ALU-RACK, black	'99	'04	Topcase Adapter not included. See page 82.	GPT.11.291.100.B
QUICK-LOCK Sidecarrier	'99	'04	Sidecase Adapter not included.	KFT.11.267.100
QUICK-LOCK EVO Tankring	'99	'04	See page 120.	TRT.00.640.16000.B
Handlebar Risers: Sprint RS	'00	'03	For Sprint RS (2000–2003): See page 10.	GM.T118
Handlebar Risers: Sprint RS	'04	'04	For Sprint RS (2004): See page 10.	GM.T119
Handlebar Risers: Sprint ST	'01	'04	For Sprint ST (2001–2004) : See page 10.	GM.T118
R&G Frame Sliders: Sprint ST	'99	'04	No cutting required: See pages 18.	RG.CP0036BL
R&G Frame Sliders: Sprint RS	'99	'04	No cutting required: See pages 18.	RG.CP0038BL
MRA Windscreen	'99	'04	Several shapes available: See page 36.	MRA.11.013

ALU-RACK, black



QUICK-LOCK Sidecarrier



Handlebar Risers



Engine Case Slider



ALU-RACK, black



Centerstand



Speed Triple 1050

[See more at TwistedThrottle.com/MyBike](http://www.TwistedThrottle.com/MyBike)

Speed Triple 955 & 1050	from	to	Notes	Part Number
ALU-RACK, black : 1050	'05	'07	For 1050 model only: Topcase Adapter not included. See page 82.	GPT.11.259.100.B
ALU-RACK, black : 1050	'08	'10	For 1050 model only: Topcase Adapter not included. See page 82.	GPT.11.502.100.B
QUICK-LOCK EVO Tankring	'01	'12	See page 120.	TRT.00.475.16000.B
Blaze Sport Saddlebags	'11	'12	QUICK-LOCK, Nylon, Black. See page 88.	HTA.11.740.10100
QUICK-LOCK GPS Holder	'11	'12	Vibration damped. Black. See page 55.	GPS.11.646.103000.B
Handlebar Risers & Barbacs	'01	'10	See page 10 (LEH.00.039150 or LEH.00.039152).	Various
Mirror Widener	'01	'10	Universal mirror widener. See page 30.	SVL.00.505.101
Centerstand	'01	'10	See page 6.	HPS.11.292.10000.B
R&G Frame Sliders	'01	'12	RG.CP0089BL, RG.CP0230, RG.CP0273BL, or RG.CP0274BL See page 18.	Various
Engine Case Slider	'05	'11	See page 20.	RG.ECS0020BK
R&G Bar End Sliders	'11	'12	See page 19.	RG.BE0031BK
R&G Front Axle Sliders	'97	'11	RG.FP0032BK, RG.FP0098BK, or RG.FP0045BK	Various

ALU-RACK, black



QUICK-LOCK Sidecarrier



R&G Radiator Guard



R&G Frame Slider



Sprint ST 1050

See more at TwistedThrottle.com/MyBike

Sprint ST & Sprint GT 1050	from	to	Notes	Part Number
ALU-RACK, black or silver	'05	'11	Topcase Adapter not included. Fits ST model only. See page 82.	GPT.11.527.100
Steel Toprack	'10	'11	Topcase Adapter not included. Fits GT model only. See page 80.	GPT.11.744.20000.B
QUICK-LOCK Sidecarrier	'05	'11	Sidecase Adapter not included. See page 84.	KFT.11.528.100
Blaze Sport Saddlebags	'10	'11	Fits GT model only. QUICK-LOCK, Nylon, Black. See page 88.	HTA.11.740.10000
QUICK-LOCK EVO Tankring	'05	'11	See page 120.	TRT.00.640.16000.B
Handlebar Risers	'05	'11	See page 10.	GM.T118
SW-MOTECH Frame Sliders	'10	'11	Fits GT model only. See page 28.	STP.11.590.10200.B
R&G Frame Sliders	'05	'11	No cutting required: See page 18.	RG.CP0269BL
R&G Front Axle Sliders	'05	'11	No cutting required: See page 19.	RG.FP0026BK
R&G Fender Eliminator	'05	'11	See page 23.	RG.LP0013BK
R&G Radiator Guard	'05	'11	See page 20.	RG.RAD0095BK
MRA Windscreen	'05	'11	Several shapes available: See page 36.	MRA.11.015

Tiger 1050



See more at TwistedThrottle.com/MyBike

ALU-RACK: Without OEM Sidecases, black



Centerstand



Skid Plate



Crashbars, black



Tiger 1050	from	to	Notes	Part Number
ALU-RACK Toprack	'07	'11	2 racks available for use with (GPT.11.527.100) and without (GPT.11.619.100.B) OEM sidecases. See page 82.	Various
QUICK-LOCK EVO Sidecarrier	'07	'11	Sidecase Adapter not included. See page 84.	KFT.11.605.200
Crashbars, black	'07	'11	See page 4.	SBL.11.610.100
Skid Plate	'07	'11	Aluminum or black. See page 7.	MSS.11.520.100
Centerstand	'07	'11	See page 6.	HPS.11.611.100
GPS Holder	'07	'11		GPS.11.458.100
Mirror Widener	'07	'11	Universal mirror widener. See page 30.	SVL.00.505.101
Handlebar Risers & Barbacks	'07	'11	See page 10 (LEH.00.039150 or LEH.00.039152).	Various
R&G Frame Sliders	'07	'11	No cutting required: See page 18.	RG.CP0248BL
MRA Windscreen	'07	'11	Several shapes available: See page 36.	MRA.11.016
Barkbusters VPS Handguards	'07	'11	See page 12.	BB.BHG23



Tiger Explorer 1200

See more at TwistedThrottle.com/MyBike

Tiger Exploer 1200	from	to	Notes	Part Number
Steel Toprack	'12		No case adapter plate required.	In Development - call
QUICK-LOCK EVO Sidecarrier	'12		Sidecase Adapter not included.	In Development - call
QUICK-LOCK EVO Tankring	'12			In Development - call
Mirror Widener	'12			In Development - call
Handlebar Risers	'12			In Development - call
Centerstand	'12		Not recommended on a lowered bike.	In Development - call
R&G Frame Sliders	'12			In Development - call
MRA Windscreen	'12		Several shapes in development.	In Development - call

Bags-Connection Speedpack



Kaoko Throttle Lock



2006 Arlen Ness Jackpot

See more at TwistedThrottle.com/MyBike

Victory (all models)	from	to	Notes	Part Number
Bags-Connection Rear Seat Bags	'05	'12	All except Cargobag and Speedpack-Wide: See page 136-141.	Various
QUICK-LOCK EVO Tankring	'05	'12	See page 120.	TRT.00.640.11000.B
Auxiliary Light Mount	'05	'12	Fender mount or to any M6 position on the bike. See page 64.	TT-D1.020.M6
Kaoko Throttle Lock	'07	'12	Big barrel and torpedo style. See page 16.	Various
Kaoko Throttle Lock	'08	'12	Big barrel style. See page 16.	KA0.SUZBBCV08

R&G Fender Eliminator



Barkbusters EGO Handguards



Handlebar Risers



WR250X

[See more at TwistedThrottle.com/MyBike](http://TwistedThrottle.com/MyBike)

WR250X & WR250R	from	to	Notes	Part Number
Handlebar Risers & Barbacks	'08	'11	See page 10.	LEH.00.039.152
R&G Fender Eliminator	'08	'12	WR250X See Page 23.	RG.LP0082BK
R&G Swingarm Spools	'09	'12	WR250X See Page 19.	RG.SP0027BK
R&G Front Axle Sliders	'09	'12	WR250X See Page 19.	RG.FP0090BK
PIAA H4 Headlight Bulb	'09	'12	Xtreme White Plus XTRA Anti-vibration. See Page 66.	PIAA.70456
MRA Windscreen	'08	'11	Several shapes available. See page 36.	Various
Barkbusters EGO Handguards	'08	'11	Other configurations available. See page 12.	BB.E514

MRA VarioTouringScreen



Airflow Windscreen

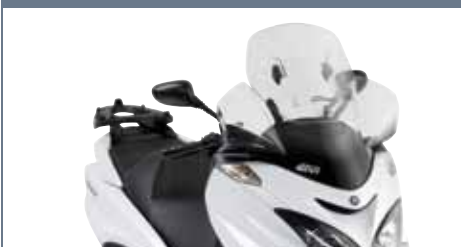

Backrest, Luggage Rack & Top Case



Majesty 400



[See more at TwistedThrottle.com/MyBike](http://TwistedThrottle.com/MyBike)

Majesty 400	from	to	Notes	Part Number
Rear Luggage Rack	'04	'12	For Givi Monokey topcases	Givi E331
Mirror Widener	'04	'12	Universal mirror widener. See page 30.	SVL.00.504.101
Reservoir Cover RAM Ball	'04	'12	Die Cast aluminum with 1" rubber RAM ball. See page 57.	RAM-B-346U
Backrest	'04	'12	For use with Givi E331, For use without Givi E331	Various
Saddlebags	'04	'12	10"x18"x13", 36-liter volume, includes rain cover.	Givi T449
Givi Windscreens	'04	'08	Spoiler Screen adds 4" to height.	Givi D137ST
Givi Windscreens	'09	'11	Special fit kit included.	Givi AF445
MRA Windscreen	'04	'12	Shape: VarioTouringScreen. See page 37.	MRA.06.054.VT.1



T-Max 500

[See more at TwistedThrottle.com/MyBike](http://TwistedThrottle.com/MyBike)

T-Max 500	from	to	Notes	Part Number
Scooter Rack	'08	'11	For Givi Monokey or Monolock topcases only	GPT.06.8008.30000.B
Backrest	'08	'11	For use without Givi SR364	Givi TB53
Windscreen	'08	'11	Available in different heights and tints. 23"h x 18"w	Givi D442
R&G Fender Eliminator	'08	'11	See page 23.	RG.LP0094CL
R&G Footboard Sliders	'08	'11	Rubberized boot grip insert, designed to reduce damage to the side of the bike in a drop or a slide.	RG.TP0003BK
Reservoir Cover RAM Ball	'08	'11	Covers brake or clutch reservoir, with 1" rubber RAM ball. Die Cast aluminum. See page 57.	RAM-B-346U
Kaoko Throttle Lock	'08	'11	See page 16.	KAO.YAMTMAX
MRA Windscreen	'08	'11	Shape: VarioTouringScreen. See page 37.	MRA.06.055.VT

R&G Fender Eliminator



Backrest



Windscreen (D442ST)



2007 FZ6

[See more at TwistedThrottle.com/MyBike](http://TwistedThrottle.com/MyBike)

FZ6	from	to	Notes	Part Number
ALU-RACK, black	'07	'09	Topcase Adapter not included. See page 82.	GPT.06.313.100.B
QUICK-LOCK EVO Sidecarrier	'04	'06	Sidecase Adapter not included. See page 84.	KFT.06.314.20000
QUICK-LOCK EVO Sidecarrier	'07	'10	S2 Fazer Sidecase Adapter not included. See page 84.	KFT.06.348.20000
QUICK-LOCK Contour Carrier	'07	'09	For use with Givi V35 PLX sidecases. See page 87.	KFT.06.348.150
QUICK-LOCK EVO Tankring	'01	'05	See page 120.	TRT.00.640.11000.B
Crashbars, black	'04	'09	See page 4.	SBL.06.316.100.B
Centerstand	'04	'06	See page 6.	HPS.06.315.100
Handlebar Risers & Barbacks	'04	'09	See page 10 (LEH.00.039.150, LEH.00.039.152, or LEH.00.039.160).	Various
Mirror Widener	'04	'10	See page 30.	SVL.00.504.101
R&G Frame Sliders	'04	'09	See page 18.	RG.CP0219
R&G Front Axle Sliders	'04	'09	See page 19.	RG.FP0054BK
R&G Fender Eliminator	'04	'09	See page 23.	RG.LP0038BK
R&G Bar End Sliders	'04	'09	See page 19.	RG.BE0013BK
MFV Vario Footpeg Mount	'04	'09	Rider & passenger options available. See page 32.	MFV.051.08.01

ALU-RACK, black



QUICK-LOCK EVO Sidecarrier



QUICK-LOCK Contour Carrier



Crashbars, black



ALU-RACK, black



SW-MOTECH Frame Slider



Centerstand



FZ6R

[See more at TwistedThrottle.com/MyBike](http://TwistedThrottle.com/MyBike)

FZ6R	from	to	Notes	Part Number
ALU-RACK, black	'10	'11	Topcase Adapter not included. See page 82.	GPT.06.479.10000.B
QUICK-LOCK EVO Sidecarrier	'10	'11	Sidecase Adapter not included. See page 84.	KFT.06.478.20000.B
QUICK-LOCK EVO Tankring	'10	'11	See page 120.	TRT.00.640.11000.B
Centerstand	'10	'11	See page 6.	HPS.06.656.10000.B
SW-MOTECH Frame Sliders	'10	'12	See page 28.	STP.06.590.10800.B
R&G Fender Eliminator	'10	'12	Includes a Twin LED license plate illumination light. See page 23.	RG.LP0079BK
R&G Engine Case Sliders	'10	'12	Left and right sides sold separately.	RG.ECS005
R&G Radiator Guard	'10	'12	See Page 20.	RG.RAD0096BK
R&G Toe Chain Guard	'10	'12	See page 22.	RG.TG0005BK
MRA X-screen Spoiler	'10	'11	Add Vario-blade to any screen See page 37	MRA.XC

R&G Engine Case Cover



R&G Aero Frame Slider



MRA Double-Bubble Racing Screen

Shown on 2006 YZF-R6



[See more at TwistedThrottle.com/MyBike](http://TwistedThrottle.com/MyBike)

YZFR6



R6, & R6S	from	to	Notes	Part Number
QUICK-LOCK EVO Tankring	'98	'12	See page 120.	TRT.00.640.11000.B
Blaze Sport Saddlebags	'08	'12	1680 Ballistic Nylon. Black. See page See page 88.	HTA.06.740.10400
Mirror Widener	'08	'12	See page 30.	SVL.06.501.10600.B
R&G Frame Sliders	'06	'12	Cut and no-cut options available See page 18.	RG.CP020
R&G Engine Case Covers	'06	'12	Right and left sides: See page 20.	RG.ECC003
R&G Engine Case Slider	'06	'12		RG.ECS0001BK
R&G Bar End Sliders	'06	'12	See page 19.	RG.BE0009BK
R&G Swingarm Spools	'98	'12	Rider and passenger mounts available See page 19.	RG.CR0002.BK
MFW Vario Footpeg Mount	'03	'12	Rider and passenger mounts available See page 32.	MFW.051.08.04
MRA Windscreen	'06	'07	Several shapes available: See page 36.	MRA.06.053
MRA Windscreen	'08	'12	Several shapes available: See page 36.	MRA.06.057



2010 FZ8

[See more at TwistedThrottle.com/MyBike](http://TwistedThrottle.com/MyBike)

FZ8	from	to	Notes	Part Number
ALU-RACK, black	'10	'12	Topcase Adapter not included. See page 82.	GPT.06.171.10000.B
QUICK-LOCK Evo Sidecarrier	'10	'12	Sidecase Adapter not included. See page 84.	KFT.06.727.20000.B
QUICK-LOCK Contour Carrier	'10	'12	For use with Givi V35 PLX sidecases. See page 87.	KFT.06.727.15000.B
QUICK-LOCK EVO Tankring	'10	'11	See page 120.	TRT.00.640.11000.B
QUICK-LOCK GPS Holder	'10	'12	Vibration damped. Black. See page 55.	GPS.00.646.10000.B
Blaze Sport Saddlebags	'10	'12	QUICK-LOCK, Nylon, Black. See page 88.	HTA.06.740.10300
Centerstand	'10	'12	Black. See page 6.	HPS.06.173.10000.B
Handlebar Risers	'10	'12	20mm, 25mm, 30mm & 50mm rise. See page 10.	LEH.00.039.150
Mirror Widener	'10	'12	Universal fit. See page 30.	SVL.00.504.101
SW-MOTECH Frame Sliders	'10	'12	Sold in pairs. See page 28.	STP.06.590.11000.B
R&G Fender Eliminator	'10	'12	See page 23.	RG.LP0024BK

ALU-RACK, black



SW-MOTECH Frame Slider



Centerstand



FZ1

[See more at TwistedThrottle.com/MyBike](http://TwistedThrottle.com/MyBike)

FZ1 (2001–2005)	from	to	Notes	Part Number
ALU-RACK, black	'01	'05	Topcase Adapter not included. See page 82.	GPT.06.238.100.B
QUICK-LOCK Sidecarrier	'01	'05	Sidecase Adapter hardware not included. See page 84.	KFT.06.095.100
QUICK-LOCK EVO Tankring	'01	'05	See page 120.	TRT.00.640.11000.B
Crashbars, black	'01	'05	See page 4.	SBL.06.318.100
Handlebar Risers & Barbacks	'01	'05	See page 10 (LEH.00.039150 or LEH.00.039152).	Various
Mirror Widener	'01	'05	See page 30.	SVL.06.501.104
R&G Frame Sliders	'01	'05	No cutting required: See page 18.	RG.CP0059BL
R&G Front Axle Sliders	'01	'05	See page 19.	RG.FP0054BK
Kaoko Throttle Lock	'01	'05	See page 16.	KAO.YAM300
MRA Windscreen	'01	'05	Several shapes available: See page 36.	MRA.06.038

ALU-RACK, black



QUICK-LOCK Sidecarrier mounting points



Crashbars, black



R&G Frame Slider



ALU-RACK, black



QUICK-LOCK EVO Sidecarrier

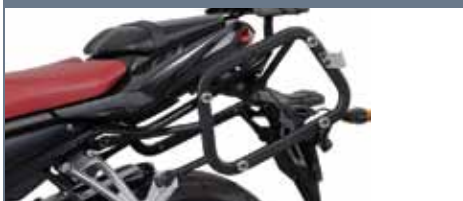

Crashbars, black

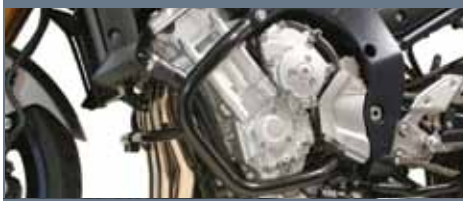

Centerstand



FZ1 Fazer

[See more at TwistedThrottle.com/MyBike](http://TwistedThrottle.com/MyBike)

FZ1 Fazer (2006 & Later)	from	to	Notes	Part Number
ALU-RACK, black	'06	'12	Topcase Adapter not included. See page 82.	GPT.06.541.100.B
QUICK-LOCK EVO Sidecarrier	'06	'12	Sidecase Adapter not included. See page 84.	KFT.06.533.20000
QUICK-LOCK EVO Tankring	'06	'12	See page 120.	TRT.00.640.11000.B
Blaze Sport Saddlebags	'06	'12	QUICK-LOCK, Nylon, Black. See page 88.	HTA.06.740.10300
Crashbars, black	'06	'12	See page 4.	SBL.06.542.100
Centerstand	'06	'12	See page 6.	HPS.06.499.100
Handlebar Risers & Barbacks	'06	'12	See page 10 (LEH.00.039150 or LEH.00.039152).	Various
R&G Frame Sliders	'06	'12	No cutting required: See page 18.	RG.CP0176.BL
R&G Engine Case Covers	'06	'12	Right and left available: See page 20.	Various
R&G Engine Case Slider	'06	'12	Right and left available.	Various
Kaoko Throttle Lock	'06	'12	See page 16.	KAO.YAM300
MRA Windscreen	'06	'12	Several shapes available: See page 36.	MRA.06.051

R&G Bar End Slider



R&G Aero Frame Slider



MRA Double-Bubble RacingScreen



YZF R-1

[See more at TwistedThrottle.com/MyBike](http://TwistedThrottle.com/MyBike)

YZF-R1	from	to	Notes	Part Number
QUICK-LOCK EVO Tankring	'04	'12	See page 120.	TRT.00.640.11000.B
Blaze Sport Saddlebags	'09	'11	QUICK-LOCK, Nylon, Black. See page 88.	HTA. 06.740.10000.B
Mirror Widener	'09	'11	See page 30.	SVL.06.501.10500
R&G Frame Sliders	'07	'12	No cutting required: See page 18.	RG.CP0197
R&G Bar End Sliders	'99	'11	See page 19.	RG.BE0009BK
R&G Swingarm Spools	'07	'12	See page 19.	RG.CR0022BK
R&G Fender Eliminator	'07	'11	See page 23.	RG.LP0040BK
R&G Adjustable Rearsets	'09	'11	Street or GP shift pattern option. See page 21.	RG.RSET08BK
Kaoko Throttle Lock	'04	'11	See page 16.	KAO.YAM500
MRA Windscreen	'07	'11	Several shapes and years available: See page 36.	MRA.06.058
MFW Adjustable Footpegs	'09	'11	Rider (MFW.051.08.04.00) & passenger (MFW.051.08.05.10 '07-'11). See page 32.	Various

Steel Toprack



QUICK-LOCK EVO Sidecarrier



Handlebar Risers



Crashbars



Skid Plate



On/Off-road Footpegs

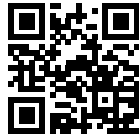

View our Super Tenere project bike video.



XT1200Z Super Tenere

[See more at TwistedThrottle.com/MyBike](http://TwistedThrottle.com/MyBike)

XT1200Z Super Tenere 1200	from	to	Notes	Part Number
Steel Toprack	'12		Accepts several different topcases. See page 80.	GPT.06.148.20000.S
QUICK-LOCK EVO Sidecarrier	'12		See page 84.	KFT.06.145.20000.B
QUICK-LOCK EVO Tankring	'12		See page 120.	TRT.00.640.11000.B
Handlebar Risers	'12		25mm rise. See page 10.	LEH.06.039.10100.S
QUICK-LOCK GPS Holder	'12		Detachable, vibration damped. See page 55.	GPS.06.646.10100.B
On/Off-road Footpegs	'12		See page 34.	FRS.06.011.10000.S
Crashbars	'12		See page 30.	SBL.06.162.10000.B
Skid Plate	'12		Aluminum. See page 7.	MSS.06.150.10000.S
Mirror Widener	'12		See page 30.	SVL.00.504.101
Auxiliary Light Mount	'12		See page 64 for Denali LED lighting.	NSW.06.004.10100.B
Adjustable Windshield Bracket	'12			MAD.S10
R&G Exhaust Header Grill	'12		Aluminum, black.	RG.DG0001BK
Kaoko Throttle Lock	'12		See page 16.	KAO.YAM630
MRA Windscreens	'12		Several shapes available: See page 36.	MRA.06.061
Fenda Extenda	'12		Provides extra protection for your radiator and engine.	PP.052100

MRA VarioTouringScreen Adjustable Windshield



QUICK-LOCK Sidecarrier



MRA Windshields



R&G Bar End Slider



2004 FJR1300



[See more at TwistedThrottle.com/MyBike](http://TwistedThrottle.com/MyBike)

FJR1300 (2001–2005)	from	to	Notes	Part Number
Luggage Rack	'01	'05	For Givi Monokey topcases only.	Givi SR357
QUICK-LOCK EVO Tankring	'01	'05	See page 120.	TRT.00.640.11000.B
QUICK-LOCK Sidecarrier	'01	'05	Sidecase Adapter not included. See page 84.	KFT.06.098.100
Handlebar Risers	'01	'05	See page 10.	LEH.06.039.114.S
Mirror Widener	'01	'05	See page 30.	SVL.06.501.101
MFV Vario Footpeg Mount	'01	'05	Rider and passenger mounts available. See page 32.	Various
R&G Frame Sliders	'01	'05	See page 18.	RG.CP0060BL
R&G Bar End Sliders	'01	'05	See page 19.	RG.BE0009BK
Kaoko Throttle Lock	'01	'05	See page 16.	KAO.YAM500
MRA Windscreen	'01	'05	Shape: VarioTouringScreen. See page 37.	MRA.06.048.VM

Steel Toprack



Auxiliary Light Mount with Denali Lamp



MRA Windscreen



FJR1300



[See more at TwistedThrottle.com/MyBike](http://TwistedThrottle.com/MyBike)

FJR1300 (2006 & Later)	from	to	Notes	Part Number
Steel Toprack	'06	'12	Accepts TraX, Coccase, & Givi Topcases. See page 80.	GPT.06.813.20000.S
QUICK-LOCK EVO Tankring	'06	'12	See page 120.	TRT.00.640.11000.B
QUICK-LOCK GPS Holder	'06	'12	Vibration damped. Black. See page 55.	GPS.06.646.10200.B
Mirror Wideners	'06	'12	See page 30.	SVL.06.501.11000.B
Handlebar Risers	'06	'12	See page 10.	GM.Y203
Auxiliary Light Mount	'06	'12	Mounts to mirror hinge. See page 64 for Denali LED lighting.	LAH.06.816.10000.B
MFV Vario Footpeg Mounts	'06	'12	Rider & Passenger options available. See page 32.	Various
SW-MOTECH Frame Sliders	'06	'12	See page 28.	STP.06.590.10300.B
R&G Bar End Sliders	'06	'12	See page 19.	RG.BE0009BK
MRA Windscreen	'06	'12	Shape: VarioTouringScreen. See page 37.	MRA.06.060.VM



Twisted Throttle Women's Contoured

When you ride, there's nothing that'll make you feel more comfortably twisted than this pre-shrunk 100% cotton, slim-fit T-shirt

S, M, L, XL, XXL, & XXXL

Color: Black
TT.TS.3: **\$10.00**



Twisted Throttle Men's Classic

The classic design of this stylish 100% cotton heavy-weight T-Shirt includes a silk screened Twisted Throttle logo. You too can be twisted!

S, M, L, XL, XXL, & XXXL

Color: Black
TT.TS.1: **\$10.00**

Back Detail



Twisted Throttle Low-Profile Baseball Cap
TT.HAT.2: **\$12.50**



Twisted Throttle Kick Pad

Tired of using a crushed soda can under your sidestand foot? How about using one of our Twisted Throttle sidestand pucks?

Black or yellow.
TT.SSP.101: **\$3.99**



Twisted Throttle Knit Winter Beanie
Part No. TT.HAT.3: **\$12.50**

Twisted Throttle PIT Shirt!
Help form our pit crew by sporting the Twisted Pit Shirt representing all our major brands 100% Polyester Full dye-sublimation printing!
TT.PIT.1: **\$99.99**



Reflective Sticker

Slap it on your bike and be seen better while riding at night!

TT.stk.01: **\$1.00**



Twisted Throttle Patch
Sew it on your favorite denim jacket!
TT.PATCH: **\$1.99**



My Dirtbike Has Slicks
Normal riding just isn't enough for you. You had to take a dirtbike and outfit it with Nascar tires. But that wasn't enough either, riding sideways is so much fun!

S, M, L, XL, XXL, & XXXL

Color: Black
TT.TS.11: **\$15.00**

Back Detail



Motorcycle vs Prius!

This one goes out to you battle commuters who insist on taking the bike to work even when it's 40 degrees and raining. It's time you get some green respect too!

S, M, L, XL, XXL, & XXXL

Color: Navy
TT.TS.7: **\$15.00**

Back is plain



IRON PIG

Rule the roads and the mud: it's Iron Pig time! Oink oink! This GS T-shirt pays homage to a beloved machine.

S, M, L, XL, XXL, & XXXL

Color: White
TT.TS.8: **\$15.00**

Back Detail



Motorist Eye Exam

Get people's attention with this bright green shirt. Make a statement and help make the roads a safer place to ride!

S, M, L, XL, XXL, & XXXL

Color: High Viz Yellow
TT.TS.9: **\$15.00**

Back Detail



KLR ARMY

You know who you are... you've signed on the dotted line. There is strength in numbers. And its time to represent.

S, M, L, XL, XXL, & XXXL

Color: Olive Drab
TT.TS.10: **\$15.00**

Back Detail



Ready for Adventure

Whether you're exploring the wilds of Alaska or riding into the Australian outback, one thing is for sure - you gotta pack the essentials for a good time!

S, M, L, XL, XXL, & XXXL

Color: Orange
TT.TS.6: **\$15.00**

Back Detail



DEALERS:

Looking for the perfect way to display your Twisted Throttle items?

Display stands are available for most products sold by Twisted Throttle. Inquire for availability!

Oxford Heatez Functional Display

Part No. OXF.PC695



DENALI D1 Display

Part No. TT-D1.DIS-SDENALI



Displays are available as free-standing (2-sided) or wall-mount (single-sided) versions.



Sidecases and Saddlebags



Footpegs and Handlebar Risers



QUICK-LOCK Tankbags

TWISTED THROTTLE PROJECT BIKES

We prototype, test and IMPROVE our products!

Twisted Throttle is not like most other motorcycle product distributors. We IMPROVE our products based on testing and customer feedback. Most companies have no creative control over what they sell. We do!

Every year, we select a few special motorcycles to deck out with our products and put them to the test in real-world conditions so that we can improve what we sell. Take a look through the photo gallery of project bikes to get an idea of just how far we go to test our products!

To expand the scope of testing, we also partner with touring/rental companies, MotoQuest (see page 238), and GSM MotoRent (see the Super Tenere on page 234). These companies give us feedback about how our products hold up over the long-term on bikes that take a ton of abuse. This information helps us to improve existing products and develop new items that we feel confident will withstand the toughest riding conditions.

We have also teamed up with industry publications to help them develop their project bikes. See the ADV MOTO magazine's ADVersys below.

Friend us on Facebook, Follow us on Twitter, subscribe to our Youtube channel and check out our website to see all of the Twisted Project Bikes and to keep up-to-date on our upcoming projects!



Fully equipped, fully versatile

SW-MOTECH Skid plate



See the video!

ADV MOTO ADVERSYS

We partnered with ADV MOTO Magazine to help create the ADVersys. Luggage and storage, ergonomics, lighting, and crash protection accessories turn this ordinary Versys into a trail and trip-ready, dual-sporting machine.

Turn to page 194-195 to see what products are available for your Versys.



HONDA CANADA VARADERO

We teamed up with Honda Canada to outfit a Honda Varadero with burly crash protection, accessories, ergonomic improvements, Denali lighting, and luggage from SW-MOTEC/Bags Connection.

Turn to page 185 to see products that fit your Varadero.



See the video!



Twisted marketing guru K. Nixoid riding through the Chasm of Doom.



The Canadian Connection



Full TRAX Luggage setup

TWISTED BMW S1000RR



Erik rolling her out.



Derek tearing her down.



Nate designing the graphics.



The completed project.

Our BMW S1000RR turns heads at the track and on the highway. Equipped with rock-solid crash protection products and style enhancements from R&G and SW-MOTEC makes this a Twisted favorite.

Turn to pages 162-163 to see what products are available for the S1000RR.



See the video!



PR Manager, Ken C, rides the S1000RR through "the bowl" at the New Hampshire Motor Speedway.

TWISTED BMW R1200GS



We outfitted our R1200GS with storage and crash protection products from SW-MOTECH/ Bags Connection, as well as Barkbusters Handguards, a Kaoko throttle lock, R&G axle sliders, and Denali lighting to create a complete adventure-bike package. This bike is ready to take on any terrain, anywhere!

To see products available for your R1200GS turn to pages 166-167.

On the road at the BMW MOA Rally...



...at ADV Eastern Rendezvous.



See the video!

TWISTED BMW F800GS

This GS lives up to its rugged family history but we knew we could make it better with durable SW-MOTECH crash protection, comfortable ergonomic upgrades, and much more. Our F800GS was the grand prize for the GS Challenge winner held at the 2011 BMW MOA Rally in Bloomsburg, PA.



Turn to page 159 to see how to transform your F800GS!



See the video of our F800GS!

Ripping it up in "the PIT".



Don't Ask...



Mr. Twisted feelin' good on Deal's Gap.



Looking pretty in the early morning light!

TWISTED KLR

The KILLER KLR!!! The trails won't know what hit 'em. The mighty KLR got the full complement of SW-MOTECH protection, ergonomic improvements, and storage. The KLR is a great bike to begin with. We just made it better.

Turn to pages 192-193 for a list of products for the KLR.

Early morning photo shoot.



Another day of Deals Gap riding.



Customer service manager, Derek, loves working on tail sections.

Matt W. from Customer Service working for the photoshoot.



See the video!

TWISTED TENERE IN DEALS GAP

We went down to GSM MOTORENT in Townsend, TN to outfit the newest member of the GSM rental fleet... a Yamaha Super Tenere!

Dan of GSM poses with Matt B. and Nate B. at Deals Gap.



Twisted Tenere bike-build on location in Tennessee.

GSM MOTORENT

You too can travel to the Great Smoky Mountains and ride the Twisted Tenere, go to GSMmotorent.com for details on rental and lodging.

Dan from GSM enjoying the Tenere.



See the video!

Twisted industrial designer, Nate, on the GSM Motorent Tenere at Deals Gap.

Turn to page 226 for Super Tenere product info.



TWISTED TRIUMPH TIGER 800

We outfitted this Tiger 800XC with R&G and SW-MOTECH crash protection, ergonomic upgrades, and luggage. This bike is ready for the road, as well as small invasions and everything in between. One of our favorites!

Turn to page 217 for more product info.

Taking the Tiger out for an early morning ride.



See the video!



She's lookin' pretty tame...



...getting there...



...from Tame to Twisted!



TWISTED PROJECT BIKES FOR 2012!

We have more projects planned for 2012, starting with the transformation of a 2012 Triumph Street Triple. Next in line is the new 2012 DL650 V-Strom. But we're not stopping there. We will be adding even more bikes to our fleet, so stay tuned throughout the year for updates on all of our Twisted project bikes!

2012 Suzuki DL650 V-Strom



Project Battle Scoot continues! This kymco scooter is our ongoing shop project...just for fun!



2012 Triumph Street Triple R



Every year, Twisted Throttle picks a few adventure riders to work with in raising money for charities. We help outfit their bikes and prepare them for round-the-world adventures undertaken to raise money for a good cause. We also provide their trip with added media visibility. If you're interested in working with us on a charitable project, send your proposals to sponsorships@twistedthrottle.com.

Stephanie Tarian

Stephanie Tarian is a sixteen year old with a purpose. This young lady is planning an epic motorcycle expedition that will take her around the world... and Twisted Throttle will be traveling right along with her! We outfitted Stephanie's 2011 BMW G650GS with rugged SW-MOTECH crashbars and skid plate for crash protection, as well as sidecarriers with TraX ALU-Boxes to securely carry her long list of necessities. To help light her way, we also installed a set of Denali LED lights!

This expedition will allow Stephanie to introduce adventure motorcycle riding to people of all ages from around the world and inspire young women and men to reach for their goals. Follow Stephanie as she circumnavigates the globe by logging onto the *Moto Teen World* and *Twisted Throttle* websites. Also, be sure to Friend Us on Facebook, and sign up to be on our mailing list so you can receive monthly updates.



"Challenges exist everywhere in life, and right now my challenge is to travel around the world on a motorcycle."

Stephanie Tarian



Stephanie believes in giving back! She will give 25% of all donations to the Make-a-Wish Foundation and participate in the Adopt-A-Wish program to help make a special kid's wish come true. www.wish.org



Scan here to see Stephanie's website and to donate to the cause.

www.mototeenworld.com



Moto Teen World

Patrick Trahan Update

18 fractures! That's the result of hitting a pick-up truck head on at 75 mph. Many of you may recall that Twisted Throttle built and sponsored Patrick on his quest to raise money for **Children's Wish Foundation** by circumnavigating the African continent.

Patrick successfully raised \$5,000.00 for the Foundation. Unfortunately, Patrick's adventure was cut short just days into the trip. Thankfully, he survived and was evacuated to Johannesburg, South Africa where his injuries were tended to. It turns out that Patrick is a fast healer! He already has plans for an April tour through Morocco. Good for you Patrick!

From Patrick's blog:
"I do believe in dreams and I will continue the fundraising when I am at home. And even if all doesn't go according to plan... do not stop dreaming."

www.rideafrica4wishes.com

www.childrenswish.org

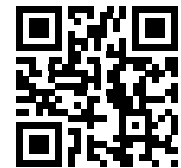

Scan here to see a video about Patrick.

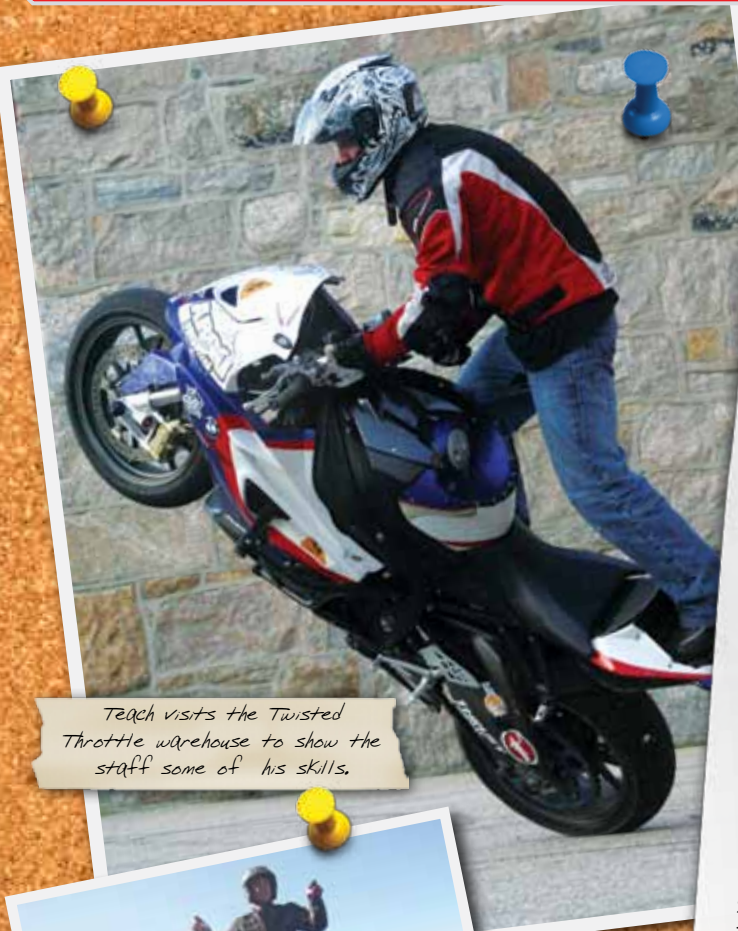

Teach visits the Twisted Throttle warehouse to show the staff some of his skills.

Chris "Teach" McNeil

Who is "Teach" McNeil? Teach is a school teacher known worldwide as one of the most skilled stunt riders on the planet. A two-time XDL East Coast Champion and 2008 Stuntwars World Champion, McNeil has put his ability to the test and WON! A Lot!

We outfitted Teach's BMW F800GS and S1000RR so that he can do the brutal R&D that none of us are willing to do. Teach intentionally crashes his bikes during his stunt shows as a way to demonstrate just how durable our crash protection is!

Teach educates us about how well each piece of crash protection performs to see if improvements can be made. This type of R&D is infinitely valuable in helping us offer the toughest luggage and strongest protection available to our customers. It's what we do.

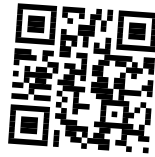

Scan this code to view an awesome video of Teach riding the Twisted-equipped BMW F800GS.



Teach demonstrates just how tough Barkusters handguards, Trax boxes, and SW-MOTECH crashbars really are.



TEACH TRIX.COM



MOTOQUEST
Ride Alaska & Beyond

Two wheels, One Life.



Twisted Throttle and MotoQuest have joined forces to offer both cutting-edge travel equipment and world-class motorcycle adventure tours.

MotoQuest offers the adventurous motorcyclist a variety of international tours, motorcycle rentals throughout North America and self-guided motorcycle tours in select locations worldwide. Ride with MotoQuest to one of our 15 global destinations and experience exceptional guides, support, motorcycles, food, and accommodations. Rent from MotoQuest and feel the joy of freedom on one of our adventure touring motorcycles. Take a self-guided tour with MotoQuest and leave the logistics of your motorcycle adventure to us. At MotoQuest, the ride is what counts. Regret is a word best left in the dictionary. Adventure is the only option. Come ride with MotoQuest.

MotoQuest is headquartered in Anchorage, AK and maintains a rental fleet of dual-sport bikes completely outfitted with Twisted Throttle gear. Each of MotoQuest's bikes sees over 20,000 miles of off-road terrain a year, including rocky river crossings, muddy single track, two-wheeled mountain climbing, multiple crashes, and more wind, rain, and snow than you'll see anywhere else in North America. MotoQuest provides Twisted Throttle with brutal feedback about what makes our gear break, serving as the harshest torture testing lab we have anywhere in the world. MotoQuest's destructive R&D help means you get a more durable, better designed product from Twisted Throttle.

Want to do some R&D for us? Sign up for one of MotoQuest's guided adventure tours, today.

MotoQuest Tour Packages include:

- Airport pick-up/drop-off
- Motorcycle rental
- Experienced Guides
- Support vehicle and mechanical support
- All accommodations
- Welcome and farewell dinners
- DVD of photos from your tour
- Detailed itinerary/maps packet
- MotoQuest motorcycle "swag bag"

Motorcycle Rentals

Rentals now available in:

- Anchorage, AK
- Seattle, WA
- Long Beach, CA
- Portland, OR
- Denver, CO

All rental bikes are outfitted with:

- Side luggage and tank bag.
- Engine guards, skid plate, hand guards, and centerstand.
- Power socket for electronics.
- Tools, spare inner tubes, and a canister for extra fuel.

Alaska-approved riding gear, including helmets, jackets, pants, gloves, and boots, are also available for rent.

To book a tour or rental, visit MotoQuestTours.com
or call MotoQuest at (800) 756-1990

Win a free "North to Alaska" Adventure!

Join Twisted Throttle & MotoQuest for the North to Alaska Adventure

Dates: May 16th 2012 - May 27th 2012
Starts in: Seattle, WA

Ride the famous Alaska Highway! This 2,650-mile journey, on all paved roads starts in Seattle, Washington and travels through western Canada to Anchorage, Alaska. Enjoy an 11-day trip of a lifetime with fantastic wildlife viewing opportunities, historic gold towns, and plenty of open road.

Highlights include:

- Ride the length of Whidbey Island and take the Deception Pass Bridge.
- Cruise the Cascade Loop Scenic Highway.
- Stay in the Okanogan Valley.
- Ride the Gold Rush Trail.
- Stay in Dawson Creek.
- Ride the World Famous Alaska Highway.
- Explore the Yukon Territory.

Available Rental Fleet:

- BMW F650GS Single, F650GS Twin, F800GS, R1200GS
- Suzuki V-Strom DL650
- Kawasaki KLR650



To sign up for a chance to win, visit
www.motoquesttours.com/giveaway.php or
SCAN HERE with your **Smart Phone's** QR Reader app:



Featured 2012 Tours



South Africa Backroads Adventure
Apr 8th 2012 - Apr 24th, 2012 (17 days)
Starts in: Cape Town

This IS the ultimate backroads adventure in South Africa with a mix of challenging dirt riding with elegant accommodations. Meet us in Cape Town, South Africa and ride to the most southern tip of Africa. This dirt-oriented adventure features epic coastline, rugged mountain passes, and wildlife. Experience the real South Africa, on and off the beaten path.



**Patagonia End of the Earth
Motorcycle Adventure Tour**
Nov 4th - Nov 20th, 2012 (17 days)
Starts in: Osorno, Chile

This tour takes you through the Andes to the most remote parts of Patagonia. See Torres Del Paine National Park, Perito Moreno Glacier and Tierra Del Fuego. Stay in Ushuaia, at the end of the earth. Along the way, see guanacos, gauchos, and glaciers. This is a ride of a lifetime.



Indochina Adventure
Nov 4th - Nov 18th, 2012 (15 days)
Starts in: Hanoi

Ride from Hanoi, Vietnam to Vientiane, Laos. This tour spans two countries, two motorcycles, two cultures, and two capital cities. Ride a Russian made Ural in Vietnam, and a Honda XR250 in Laos. The riding is challenging with roads that are dirt and paved. Enjoy thousands of curves, remote villages, and friendly smiles as you ride through extremely mountainous country.



**Coming soon:
Iceland Explore**

August 2012

For a complete list of Tours, visit MotoQuestTours.com!

Twisted Throttle LLC and MotoQuest are independently owned and operated companies.

2012-2013 Event Calendar

Visit Twisted Throttle at these rallies around the country!

Events subject to change without notice.

Visit www.twistedthrottle.com/calendar for the latest schedule!

 = **Attended event.** Twisted Throttle will be in attendance so stop by and see us!

 = **Sponsored event.** Twisted Throttle may not attend but will offer prizes and event support.

Cycle World International Motorcycle Shows

November - February

Chicago, IL	New York, NY
Cleveland, OH	Novi, MI
Dallas, TX	San Mateo, CA
Daytona, FL	Seattle, WA
Greenville, SC	Washington, DC
Minneapolis, MN	

Visit our website for 2012-2013 show dates!
www.motorcycleshows.com

 **Dealernews Dealer Expo**
Indianapolis Convention Center & RCA Dome
Indianapolis, IN

February 17-19, 2012
www.dealerexpo.com

 **Daytona Bike Week**
Daytona International Speedway
1801 W. International Speedway Blvd
Daytona, FL

March 9-17, 2012
www.daytonachamber.com/daytonabikeweek/

 **BMW Georgia Mountain Rally**
Georgia Mountain Fairgrounds
1311 Music Hall Rd (Hwy 76 W)
Hiawassee, GA 30546

May 4-6, 2012
www.bmwmoa.info

 **Eastern V-Strom Gathering IV**
Iron Horse Campground
1755 Lower Stecoah Road
Stecoah, NC

May 12-15, 2012
www.vstrom.info
Lodging information:
www.ironhorsenc.com

 **Morton's BMW Spring Fling Rally**
Natural Bridge Hotel, VA 22408

May 18-20, 2012
www.mortonsbmw.com

 **ADV Rider 11th Annual Eastern Rendezvous**

The Stations Inn and
Freebornes Eatery and Lodge
BRP milepost 248
Laurel Springs, NC

May 18-22, 2012
www.advrider.com
Lodging information:
www.freebornes.com and www.stationsinn.com

 **Concours Owners Group (COG) Spring Fling**

Winnapaug Inn
Westerly, RI
May 17-20, 2012

www.forum.cog-online.org
Lodging information:
www.winnapauginn.com

 **Twisted Throttle 10 Year Anniversary /
New facility Grand Opening Mega-Fest**
Join us for free food, door prizes,
& discounts on great stuff!

570 Nooseneck Hill Rd
Exeter, RI 02822

Saturday, May 19, 2012
www.twistedthrottle.com

 **Americade TourExpo**

2200 State Route 9
Lake George, NY

June 5-9, 2012
www.tourexpo.com

 **Concours Owners Group (COG) Nat'l Rally**

Eureka Springs, AR
June 11-15, 2012

concours.org/nationalrally2012
Lodging information:
concours.org/nationalrally2012/looding

 **BMW MOA International Rally**

Missouri State Fairgrounds
Sedalia, MO

July 19-22, 2012
www.bmwmoa.org/rally12

 **Rally Week In The Gorge**
(a.k.a. **Sport Touring Northwest**)

Columbia River Gorge/Skamania Fairgrounds
720 SW Rock Creek Dr
Stevenson, WA

August 1-5, 2012
www.soundrider.com/stour/rally

 **Colors in the Catskills**
BMW MOA Regional Rally

Hunter, New York

First weekend of October, 2012
www.bmwmoa.org/forum

 **Mortons BMW Octoberfest**

5099 Jefferson Davis Highway
Fredericksburg, VA 22408

October, 2012

 **Canadian Motorcycle Shows**

December - January

Toronto, ON	Edmonton, AB
Calgary, AB	Vancouver, BC

Visit our website for 2012-2013 show dates!
www.sportshows.ca

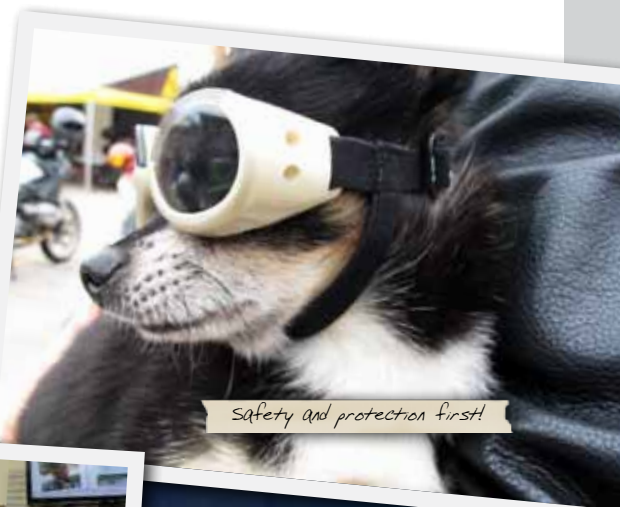

Safety and protection first!



*Twisted Open House 2010
photo by Purchasing Manager, Dan Coyne*



*PR Manager and author of "Riding
in the Zone", Ken Condon, at the
2010 Twisted Open House.*



*Designer and videographer,
Matt mixing it up in Austria.*

How to Order

We're just a call or a click away!

Order 2 ways:

1. Order online 24/7 at TwistedThrottle.com

2. Call Us

+1 (855) 255-5550 toll free in North America

+1 (401) 284 4200 International

Monday - Friday 9:00am - 7:30pm Eastern Time (GMT-5)

Saturday 10:00am - 6:00pm Eastern Time (GMT-5)

COME VISIT!

If you are traveling through New England, come visit our showroom and the nearby southern Rhode Island coastline! Give us a call and we'll help you with hotel, or campgrounds, directions, etc. You can download maps and directions at TwistedThrottle.com/contact.

GPS: +41.56484, -71.65942

PAYMENT METHODS



We accept Visa, MasterCard, Discover, and American Express for online, phone, and fax orders. Checks, money orders, and wire transfers are acceptable for mail orders.

GIFT CERTIFICATES

Need to find a gift for your favorite motorcyclist, but not sure what they need for their next big trip? Purchase a gift certificate online and we'll send you, or the recipient, a Gift Certificate for the requested amount along with a copy of our catalog!

PROFESSIONAL DISCOUNTS

We offer a 10% discount to active MSF Instructors, media test riders and writers for print magazines. We hope that this will encourage introduction of our products to potential customers through rider-to-rider endorsements. Give us a call or send us an email to get set up with the discount.

OUTLET STORE (Scratch and Dent)

We offer discounts on returned, scratched, dented, overstocked, and discontinued closeout items through our outlet store at TwistedThrottle.com/outletstore.

SHIPPING POLICY

We ship worldwide! In-stock items ship within 1 business day from our Rhode Island warehouse. Items in stock and shipping from one of our satellite warehouses in other locations typically ship within 1-3 business days. Call us to place your order if you need delivery by a specific date! If an item is not available for immediate shipment, we will email and call you to notify you of what the expected ship date is, as well as recommend in-stock alternatives or provide the option of cancelling the order.

We ship all domestic packages via FedEx. Shipments to locations outside of the United States can be shipped via FedEx or USPS Global Express Mail. In addition to our shipping fees, the recipient is responsible for paying any brokerage or duties due on international shipments.

You will automatically receive an email confirming your order, and will receive a second email with a tracking number within 1 business day of when we ship your order.

The BMW Rally in Garmisch, Germany. Lots of bikes, beer, and some kind of german meat.



Adam R. getting ready to head out to the ADV Easter Rendezvous

RETURN POLICY

Returns and exchanges for stock merchandise, less all shipping fees, are accepted for items returned in new, uninstalled, unused condition with all original packaging. The client must pay the cost of return shipping. If a shipment arrives damaged or defective, contact us IMMEDIATELY via phone or email. We will replace the damaged or defective part with an identical new item at no cost to you following the return of the damaged or defective part.

No returns or exchanges are accepted on items shipped more than 45 days ago, windscreens that have been removed from their original factory sealed packaging, items that have been installed on a motorcycle, or special orders.

ARRANGING A RETURN

Call our Customer Service Department during normal business hours to obtain a Return Authorization Number (RA) prior to sending the return package. Please make sure to package the parts in all their original packaging and pack the return shipment so that all parts will be protected from damage during return shipment. Include your original invoice in the box and write the Return Authorization Number (RA) on the outside of the box. Ship the package to:

Twisted Throttle
ATTN: Returns
570 Nooseneck Hill Rd
Exeter, RI 02822
USA



Did we goof up?

Is something confuzzled? Help us make our catalog better! If you're the first person to point out a particular error in our catalog, we'll send you a free Twisted Throttle T-shirt. Woohoo!



**TWISTED
THROTTLE**.COM

SW-MOTEC
BAGS-CONNECTION



DENALI

MAGNA

OXFORD
Essential Rider Equipment



KAOKO
Cruise Controls



stebel



DRYSPEC
WATERPROOF LUGGAGE BY TWISTED THROTTLE



AdMore
LIGHTING INC.
Innovative LED Lighting Solutions



GIVI

ULTIMATE PROTECTION
Barkbusters
HANDGUARDS

STOP & GO



Twisted Throttle LLC
570 Nooseneck Hill Rd
Exeter, RI 02822 USA 41.56484 N, 71.65942 W

+1(855) 255-5550 toll free within North America
+1(401) 284-4200 phone
+1(401) 223-6954 fax
info@twistedthrottle.com - www.twistedthrottle.com



Port Of Touring Accessories and for 100% motorcycle:

2012 Catalog